

Bridge Maywood Site

Updated Traffic Impact Analysis

July 16, 2021

Prepared for:

*Bridge Development Partners, LLC
10655 NE 4th Street, Suite 500
Bellevue, WA 98004*

Prepared by:



Transportation Engineering NorthWest

11400 SE 8th Street, Suite 200
Bellevue, WA 98004
Office: (425) 889-6747

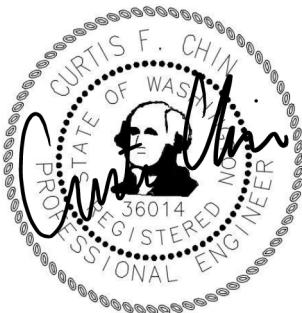

7/16/2021

Table of Contents

- FINDINGS/CONCLUSIONS 1**
- INTRODUCTION 2**
 - Project Description 2
 - Project Approach 2
 - Primary Data and Information Sources 3
- EXISTING CONDITIONS 6**
 - Roadway Network 6
 - Nonmotorized Transportation Facilities 6
 - Existing Traffic Volumes 6
 - Level of Service 9
- FUTURE TRAFFIC CONDITIONS AND PROJECT IMPACTS 10**
 - Planned Transportation Improvements 10
 - Project Trip Generation 12
 - Project Trip Distribution and Assignment 12
 - Future Traffic Volumes 15
 - Future Level of Service 19
 - Site Access Analysis 20
 - Non-Motorized Transportation Impacts 20
- MITIGATION 21**
 - Frontage/Access Improvements 21
 - Off-Site Improvements 21
 - Transportation Impact Fees 21

Appendices

- Appendix A – Peak Hour Turning Movement Counts
- Appendix B – Level of Service (LOS) Calculations
- Appendix C – Trip Generation Calculations

List of Figures and Tables

Figure 1	Project Site Vicinity	4
Figure 2	Preliminary Site Plan	5
Figure 3	2021 Existing Weekday Peak Hour Traffic Volumes	8
Figure 4	Peak Hour Project Trip Assignment at Study Intersections	13
Figure 5	Peak Hour Project Trip Assignment at Site Driveways	14
Figure 6	2023 Without Project Weekday Peak Hour Traffic Volumes	16
Figure 7	2023 With Project Weekday Peak Hour Traffic Volumes at Study Intersections.....	17
Figure 8	2023 With Project Weekday Peak Hour Traffic Volumes at Site Driveways	18
Table 1	Existing Roadway Network Summary – Project Site Vicinity.....	6
Table 2	2021 Existing Peak Hour LOS Summary	9
Table 3	Project Trip Generation Summary.....	12
Table 4	Project Trip Distribution.....	12
Table 5	Year 2023 Peak Hour LOS Summary	19
Table 6	Year 2023 Peak Hour Level of Service Summary at Site Access Locations	20

FINDINGS/CONCLUSIONS

This traffic impact analysis (TIA) has been prepared for the proposed Bridge Maywood Site warehouse development that is generally located on the north side of S 200th Street and east of Des Moines Memorial Drive S in SeaTac, WA. This is an update to the previous TIA dated March 1, 2021, which addresses City comments dated May 28, 2021 and reflects the current proposed site plan.

Project Proposal. Current plans for the project include the development of two buildings with a total building area of approximately 310,000 square feet (SF) for warehousing uses. The existing site includes several parcels including the former Maywood Elementary School, six (6) single-family detached housing, and several vacant lots. The former elementary school was closed and declared surplus by the district in 1975. Most recently, the site has been used by the district for archive storage and to house instructional resource programs. Vehicular access to the proposed warehouse development would be provided by two (2) full access driveways on S 200th Street which serves Building A and one (1) full access driveway on Des Moines Memorial Drive S which serves Building B. A secondary access driveway would also be provided for Building B on Des Moines Memorial Drive S primarily to satisfy emergency vehicle access requirements. For this analysis, a full buildout and occupancy horizon year of 2023 was used.

Trip Generation. The proposed warehouse project is estimated to generate 478 net new weekday daily trips, with 59 net new trips occurring during the weekday AM peak hour (48 in, 11 out), 33 net new trips occurring during the afternoon peak hour (16 in, 17 out) and 59 net new trips occurring during the weekday PM peak hour (14 in, 45 out).

Future Year LOS. LOS analyses were conducted for the future year 2023 conditions at four (4) off-site study intersections in the project vicinity during the weekday AM, afternoon, and PM peak hours. Based on the analysis results, all off-site study intersections are anticipated to operate at an acceptable LOS E or better during the peak hours in 2023 without or with the proposed project.

Site Access. Weekday AM, afternoon, and PM peak hour LOS analyses were conducted at the three (3) site access driveways. Based on the analysis results, all site access driveways are anticipated to operate at an acceptable LOS E or better during the peak hours in 2023 with the proposed project.

Mitigation.

Frontage Improvements

S 200th Street – half-street improvements including 6-foot sidewalk, 4-foot planter, curb and gutter, 5-foot bike lane, and 11-foot travel lane.

Des Moines Memorial Drive S – potential 2 feet to 6 feet of right-of-way dedication.

Off-Site Improvements

Based on the results of the analysis shown in this report, no project-specific off-site transportation mitigation is proposed for concurrency or SEPA purposes.

Transportation Impact Fees

The payment of transportation impact fees will mitigate project-related transportation impacts. Transportation impact fees will be determined by the City of SeaTac and will need to be paid at the time of a building permit issuance. As of the date of this study, the adopted City of SeaTac 2021 impact fee schedule identifies a fee of \$709 per 1,000 square feet for Warehousing and \$3,730 for Single Family Detached Housing.

INTRODUCTION

This traffic impact analysis (TIA) has been prepared for the proposed Bridge Maywood Site warehouse project generally located on the north side of S 200th Street and east of Des Moines Memorial Drive S in SeaTac, WA as shown in the **Figure 1** vicinity map.

Project Description

The proposed Bridge Maywood Site warehouse project includes the development of two buildings with a total building area of approximately 310,000 square feet (SF) for warehousing uses. The existing site includes several parcels including the former Maywood Elementary School, six (6) single-family detached housing, and several vacant lots. The former elementary school was closed and declared surplus by the district in 1975. Most recently, the site has been used by the district for archive storage and to house instructional resource programs. Vehicular access to the proposed development would be provided by two (2) full access driveways on S 200th Street which serves Building A and one (1) full access driveway on Des Moines Memorial Drive S which serves Building B. A secondary access driveway would also be provided for Building B on Des Moines Memorial Drive S primarily to satisfy emergency vehicle access requirements.

For this analysis, a full buildout and occupancy horizon year of 2023 was used. A preliminary site plan is provided in **Figure 2**.

Project Approach

Based on traffic scoping with City of SeaTac staff, the following tasks were undertaken to evaluate and disclose the traffic impacts associated with the Bridge Maywood project:

- Assessed existing conditions through field reconnaissance and reviewed existing planning documents;
- Described and assessed existing transportation conditions in the area;
- Documented planned transportation improvements in the site vicinity;
- Documented existing traffic volumes and intersection levels of service (LOS) at the following four study intersections during the weekday AM, afternoon, and PM peak hours:
 1. Des Moines Memorial Drive S / S 192nd Street
 2. 1st Ave S (SR 509 S) / S 199th Street
 3. Des Moines Memorial Drive S / S 200th Street
 4. 26th Avenue S / S 200th Street
- Estimated trip generation and documented trip distribution and assignment of weekday AM, afternoon, and PM peak hour project-generated traffic;
- Documented traffic forecasts and assumptions for year 2023 conditions at the four study intersections without and with the proposed development;
- Analyzed weekday peak hour LOS for year 2023 conditions at the four study intersections without and with the proposed development;
- Analyzed weekday peak hour LOS analyses at the proposed site accesses;
- Identified transportation mitigation to the City of SeaTac.

Primary Data and Information Sources

- City of SeaTac *Transportation Master Plan*, July 2015.
- City of SeaTac *2021 – 2026 Transportation Improvement Program*.
- *Des Moines Memorial Drive Corridor Management Plan*, January 2005.
- Institute of Transportation Engineers (ITE) *Trip Generation Manual*, 10th Edition, 2017 and 2020 Supplement.
- Weekday AM, afternoon, and PM Peak Hour traffic counts by All Traffic Data, February 2021.
- Traffic Signal Timing provided by King County and WSDOT, February 2021.
- *Highway Capacity Manual (HCM 6th Edition)*, 2016.



Figure 1: Project Site Vicinity



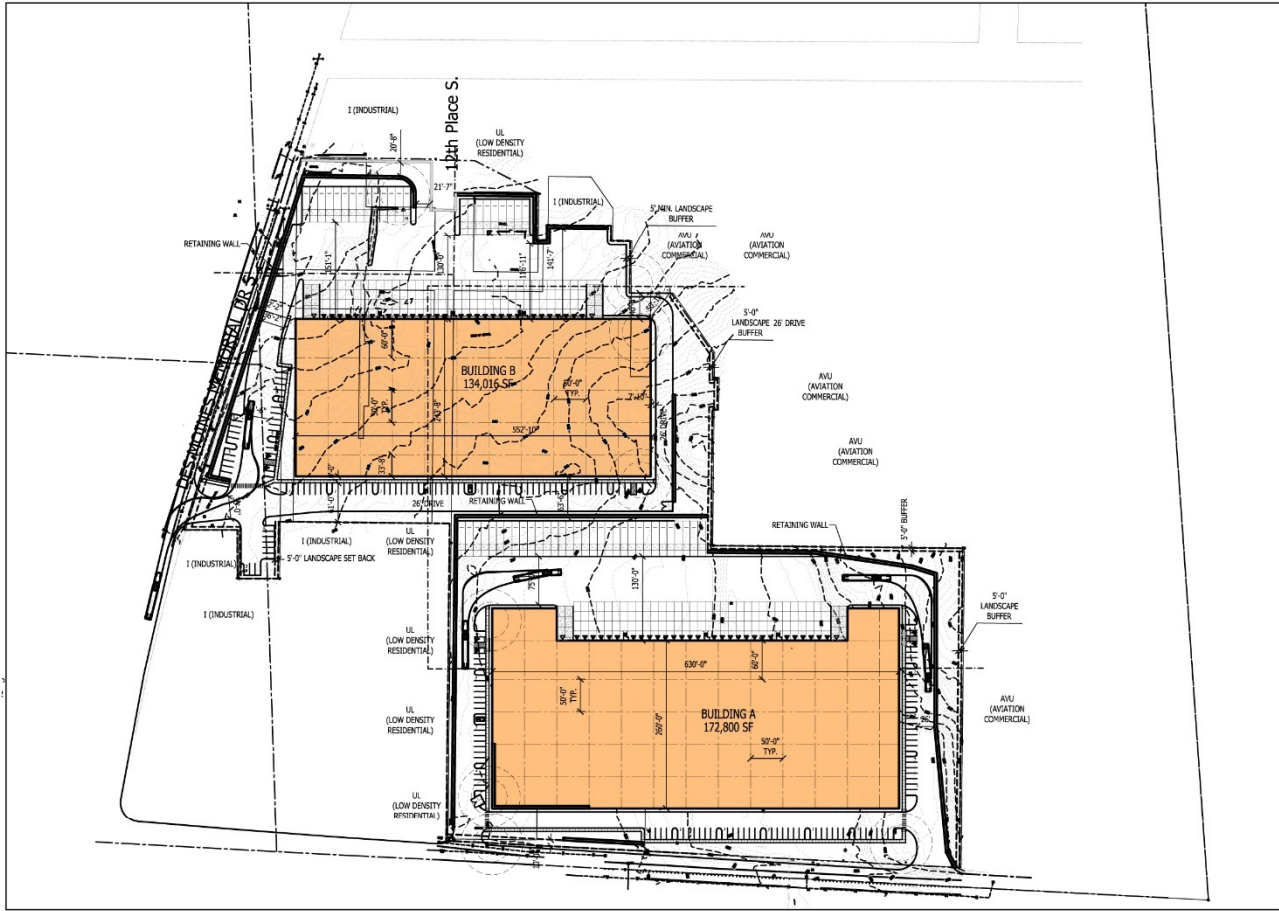

Figure 2: Preliminary Site Plan



EXISTING CONDITIONS

Roadway Network

Table 1 describes the existing characteristics of the streets that would be used as primary routes to and from the site. Roadway characteristics are described in terms of orientation, arterial classification, posted speed limits, number of lanes, pedestrian facilities, and bicycle facilities. The relationship of these roadways to the project site is shown in **Figure 1**.

**Table 1
 Existing Roadway Network Summary – Project Site Vicinity**

Roadway	Orientation	Classification	Speed Limit	Number of Travel Lanes	Sidewalks	Bicycle Facilities
S 200 th Street	East-West	Principal Arterial	35	2-5	Yes*	Yes*
Des Moines Memorial Dr S	North-South	Minor Arterial	35	2	Yes**	Yes**

* East of Des Moines Creek Trail midblock pedestrian signal and west of 12th Place S.

** Vicinity of S 200th Street.

Nonmotorized Transportation Facilities

Existing pedestrian facilities in the immediate project vicinity include sidewalks and bike lanes on S 200th Street west of 12th Place S and east of the Des Moines Creek Trail midblock pedestrian signal. Sidewalks and bike lanes also exist on Des Moines Memorial Drive S in the vicinity of S 200th Street. A mid-block pedestrian signal is located on S 200th Street east of the project site which services the Des Moines Creek Trailhead. Marked crosswalks are also located on all legs at the Des Moines Memorial Drive S /S 200th Street intersection. It should be noted that the *S 200th Street Shared Use Path* project located on the south side of S 200th Street between Des Moines Memorial Drive S and the Des Moines Memorial Creek Park Trail is currently under construction which would provide a pedestrian and bicycle connection along S 200th Street between 12th Place S and the Des Moines Creek Trailhead.

Existing Traffic Volumes

Year 2021 existing weekday AM, afternoon, and PM peak hour traffic volumes at the study intersections were estimated based on recent February 2021 turning movement counts collected by All Traffic Data and historical 2017 turning movement counts provided by the City of SeaTac. The AM peak hour traffic volumes represent the highest hourly volume of vehicles passing through an intersection between 7:00 and 9:00 AM, the Afternoon peak hour traffic volumes represents the highest hourly volume of vehicles between 1:00 and 3:00 PM, and the PM peak hour traffic volumes represent the highest hourly volume between 4:00 and 6:00 PM.

At the study intersection of Des Moines Memorial Drive S/200th Street S, 2017 turning movement counts were provided by the City. An annual growth rate of 2 percent was applied to the 2017

turning movement counts to estimate existing 2021 peak hour traffic volumes. Since the 2017 counts represent pre COVID-19 conditions, no adjustments were made to estimate existing (2021) peak hour traffic volumes at the Des Moines Memorial Drive S/S 200th Street intersection. To account for lower-than-normal traffic conditions at the remaining study intersections due to the COVID-19 pandemic, adjustments to the throughput volumes to match the pre COVID-19 upstream/downstream volumes were made to estimate 2021 peak hour traffic volumes.

Figure 3 illustrates the resulting adjusted 2021 weekday AM, afternoon, and PM peak hour traffic volumes at the study intersections. The detailed peak hour turning movement count sheets are provided in **Appendix A**.

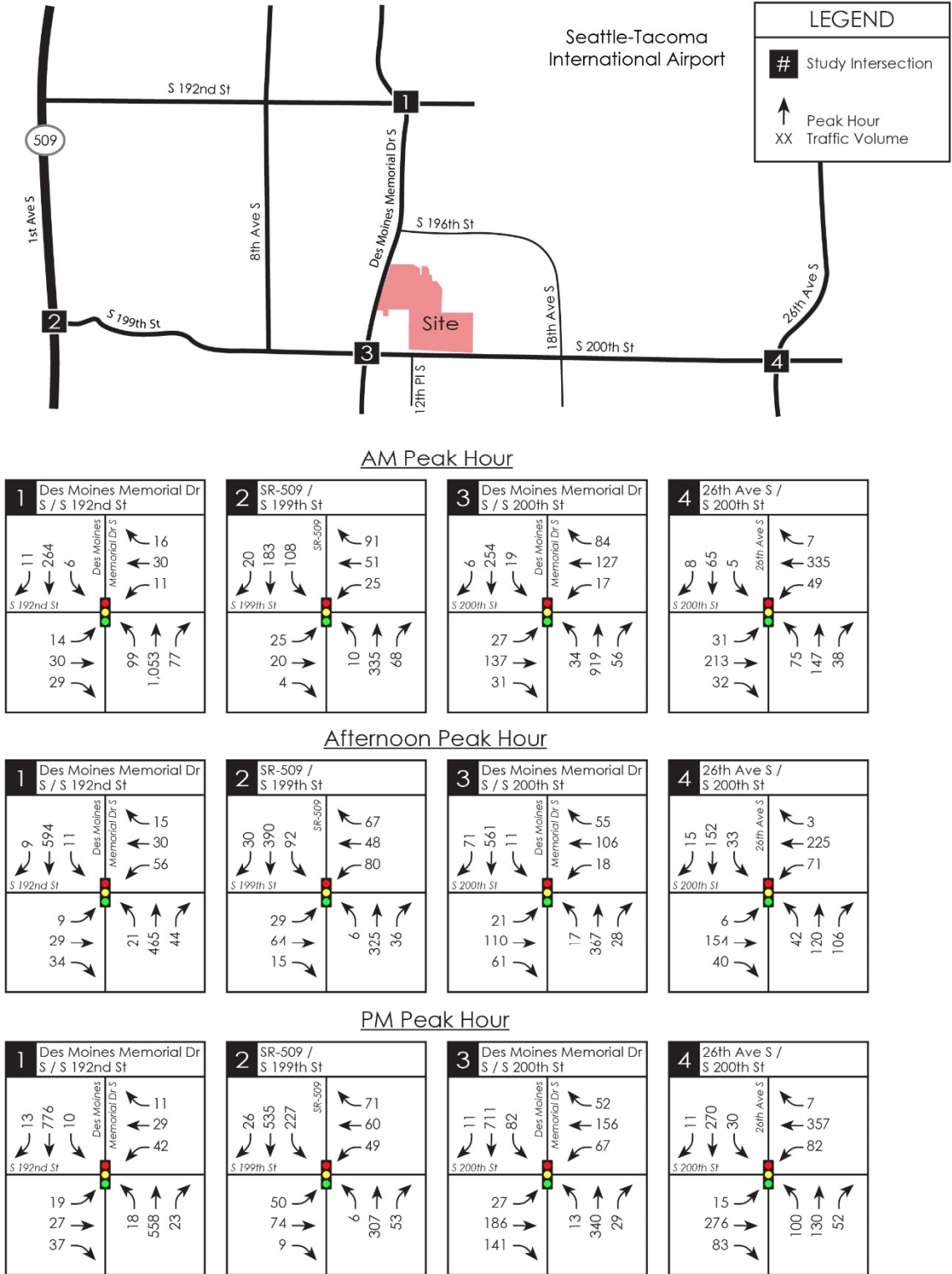

Figure 3: 2021 Existing Weekday Peak Hour Traffic Volumes



Level of Service

Weekday AM, afternoon, and PM peak hour level of service (LOS) analyses were conducted at the following four signalized study intersections:

1. Des Moines Memorial Drive S / S 192nd Street
2. 1st Ave S (SR 509) / S 199th Street
3. Des Moines Memorial Drive S / S 200th Street
4. 26th Avenue S / S 200th Street

The LOS analyses were conducted using the methodologies and procedures outlined in the latest edition of the *Highway Capacity Manual* (6th Edition). LOS serves as an indicator of the quality of traffic flow and degree of congestion at an intersection or roadway segment. It is a measure of vehicle operating speed, travel time, travel delays, and driving comfort. The LOS methodology is described in **Appendix B**. The *Synchro Version 10* software package was used to determine LOS. The existing signal timing used in the analysis was provided by King County and WSDOT.

The 2021 existing weekday AM, afternoon, and PM peak hour LOS analysis results for the study intersections are summarized in **Table 2**. The 2021 existing LOS worksheets are included in **Appendix B**.

Table 2
2021 Existing Peak Hour LOS Summary

Study Intersection	2021 Existing Conditions	
	LOS ¹	Delay (sec) ²
<u>AM Peak Hour</u>		
1. Des Moines Memorial Drive S / S 192nd St	C	33.4
2. 1st Ave S (SR 509) / S 199th St	B	15.1
3. Des Moines Memorial Drive S / S 200th St	C	31.5
4. 26th Avenue S / S 200th St	B	10.9
<u>Afternoon Peak Hour</u>		
1. Des Moines Memorial Drive S / S 192nd St	B	15.4
2. 1st Ave S (SR 509) / S 199th St	B	14.3
3. Des Moines Memorial Drive S / S 200th St	C	20.9
4. 26th Avenue S / S 200th St	B	10.9
<u>PM Peak Hour</u>		
1. Des Moines Memorial Drive S / S 192nd St	B	14.9
2. 1st Ave S (SR 509) / S 199th St	B	15.2
3. Des Moines Memorial Drive S / S 200th St	C	26.4
4. 26th Avenue S / S 200th St	B	11.5

1. LOS = Level of Service

2. Delay refers to average control delay expressed in seconds per vehicle.

As shown in **Table 2**, all study intersections currently operate at LOS C or better during the weekday peak hours.

FUTURE TRAFFIC CONDITIONS AND PROJECT IMPACTS

Planned Transportation Improvements

This section documents the known planned transportation improvements in the immediate site vicinity. The following planning documents were reviewed; City of SeaTac's 2021-2026 Transportation Improvement Program (TIP), 2015 *Transportation Master Plan (TMP)*, and the *Des Moines Memorial Drive Corridor Management Plan*, January 2005.

2021-2026 TIP Projects

- **TIP Priority #7 ST-N80 S 200th St Pedestrian and Bicycle Shared Pathway Project**
This project will design and construct approximately 3,500 lineal feet of 10 ft wide shared pathway. Location: S 200th St between Des Moines Memorial Dr S and the Des Moines Creek Trailhead. The project is currently under construction as of the date of this study and is anticipated to be completed by April 2021.
- **Other Agency: MP-043.1 SR 509 Extension Phase 1**
This project will construct a new, full access control freeway, with tolls, to connect the existing SR 509 freeway terminus with 28th/24th Ave S and I-5. Phase 1 includes two lanes each way, with truck climbing lanes, between S 188th St and 28th/24th Ave S. Two lanes each way are planned between 28th/24th Ave S and I-5. The anticipated completion of the project is 2028.

2015 Transportation Master Plan Projects

- **TMP #ST-051 Des Moines Memorial Dr S (S 194th St to S 208th St)**
The project will reconstruct and widen the road to include storm drainage, bicycle lanes, landscaping, street lighting, channelization, signal modification, paving, and modify the overhead utility lines. Install curb, gutter, and sidewalks (one side). The timing of the project is beyond 2027.
- **TMP #ST-065 Des Moines Memorial Dr S & S 200th Street**
The project includes widening to provide left turn lanes on all legs, and right turn lane on east leg. Upgrade traffic signal and channelization improvements. The improvements would be done in partnership with Des Moines. These improvements have already been completed.
- **TMP #ST-077 S 200th St (Des Moines Memorial Creek Park Trail to Des Moines Memorial Dr)**
The project will widen S 200th Street to principal arterial standards, including curb, gutter, and pedestrian and separated bicycle facilities, associated intersection improvements, consolidation of driveways, and possible underground of overhead utility improvements. Facility will be three lanes except between Des Moines Creek Park trailhead and 14th Ave S where there will be two lanes. The timing of the project is beyond 2035.
- **TMP #ST-160 S 200th Street (28th/24th Ave S to Des Moines Creek Park Trail)**
The project includes widening three lanes, including drainage, curb, gutter, sidewalks, and bicycle lanes. The timing of the project is beyond 2027.

Des Moines Memorial Drive Corridor Management Plan, January 2005

- **Confluence Segment**

The portion of Des Moines Memorial Drive (DMMD) in the project vicinity is located with the “Confluence Segment” of the *Des Moines Memorial Drive Corridor Management Plan*. The following provides a graphic of the planned road section for the Confluence Segment which includes a 3-lane section with curb, gutter, and sidewalks.

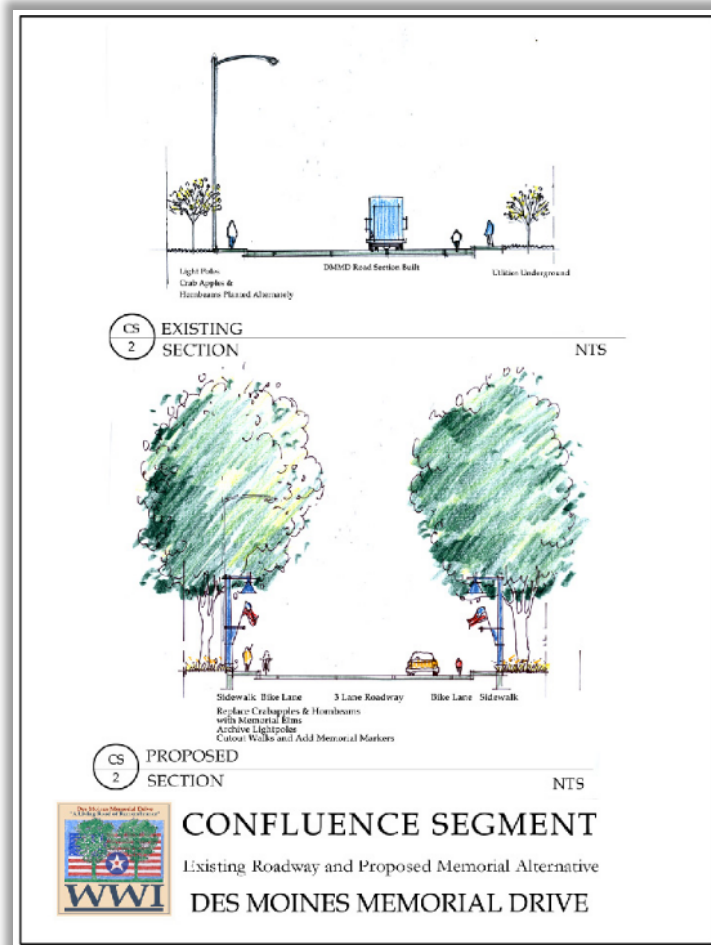

Other Planning Documents

- **Lake to Sound Trail (Segment C)**

The Lake to Sound Trail, once complete, will be a 16-mile non-motorized, multi-use recreational trail spanning from the south end of Lake Washington in Renton, all the way to the shoreline of Puget Sound in Des Moines. Segment C of the Lake to Sound Trail is located within the City of SeaTac and requires the vacation of S 196th Street and 18th Avenue S between Des Moines Memorial Drive and S 200th Street. Starting at the end of 2021 or the beginning of 2022, vehicles will no longer have access to 18th Avenue S and S 196th Street.

Project Trip Generation

The trip generation estimates for the proposed project were based on methodology documented in the Institute of Transportation Engineers (ITE) *Trip Generation Manual*, 10th Edition (2017) and its Supplement (2020) for Land Use Code (LUC) 150 (Warehousing). Trip reductions were applied to account for the six (6) existing single single-family detached homes to be removed as part of the proposed project.

The resulting net new weekday daily, AM peak hour, afternoon peak hour, and PM peak hour trip generation estimates for the proposed project are summarized in **Table 3**. Detailed trip generation calculations are included in **Appendix C**.

Table 3
Project Trip Generation Summary

Weekday Time Period	Net New Trips Generated								
	Truck Trip			Non-Truck Trip			Total Trips		
	In	Out	Total	In	Out	Total	In	Out	Total
Daily	93	93	186	146	146	292	239	239	478
AM Peak Hour	3	3	6	45	8	53	48	11	59
Afternoon	6	5	11	10	12	22	16	17	33
PM Peak Hour	5	4	9	9	41	50	14	45	59

As shown in **Table 3**, the proposed Bridge Maywood Site project is estimated to generate 478 net new weekday daily trips, with 59 net new trips occurring during the weekday AM peak hour (48 in, 11 out), 33 net new trips occurring during the afternoon peak hour (16 in, 17 out) and 59 net new trips occurring during the weekday PM peak hour (14 in, 45 out).

Project Trip Distribution and Assignment

The distribution of the new project trips generated by the Warehouse project was based on anticipated travel patterns in the study area and coordination with City of SeaTac staff as part of the Traffic Scoping for the project. The following **Table 4** summarizes the general trip distribution patterns.

Table 4
Project Trip Distribution

Route (Direction)	Trip Distribution (%)	
	Non-Truck	Truck
S 200 th St (east)	70%	75%
Des Moines Memorial Dr (north)	15%	25%
Des Moines Memorial Dr (south)	10%	0%
S 200 th Street (west)	5%	0%
TOTAL	100%	100%

Based on the trip distribution percentages, the weekday peak hour project trips were assigned through the study intersections and site access driveways. The resulting distribution and assignment of the peak hour project trips through the study intersections and site driveways is shown in **Figures 4 and 5**.

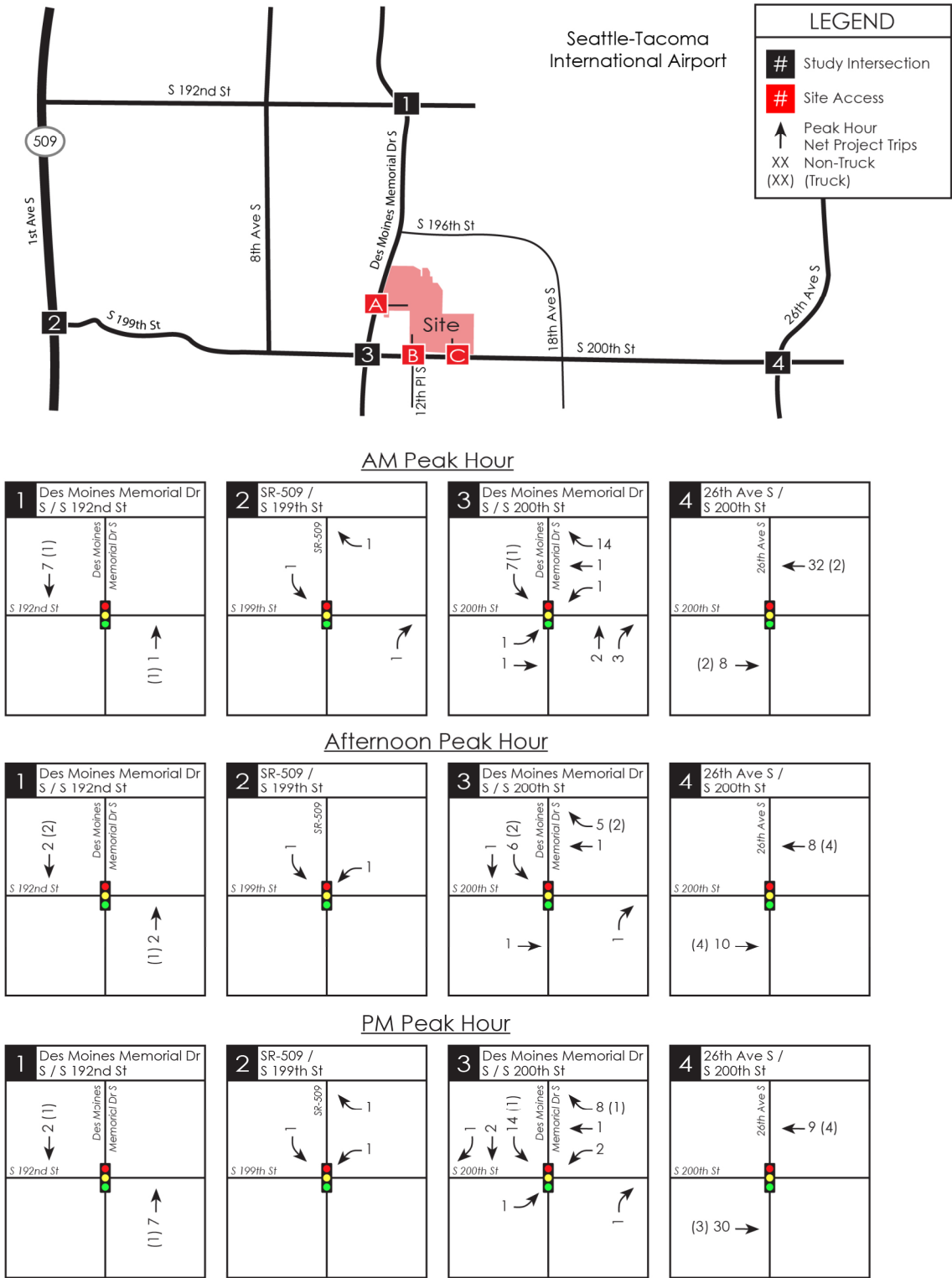
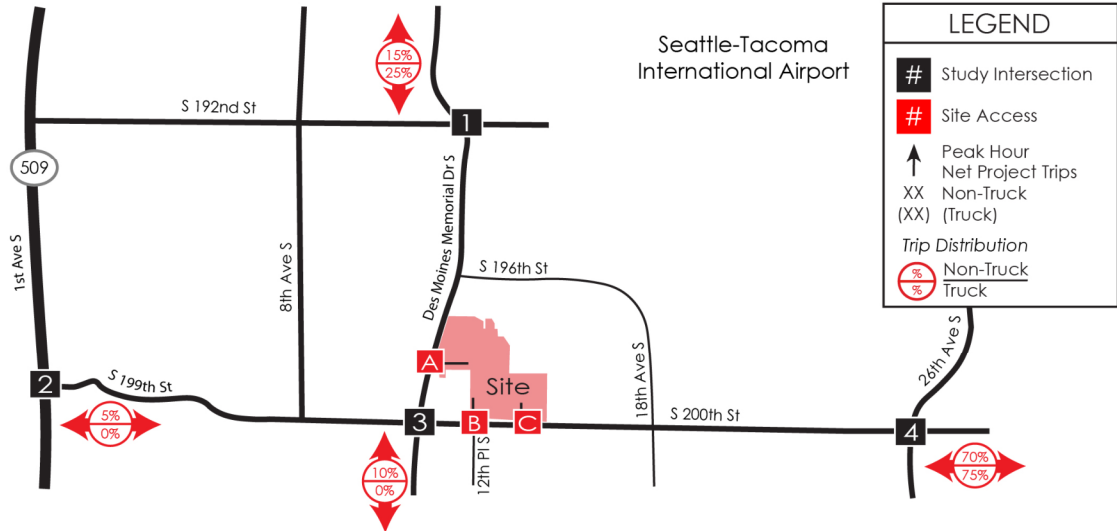

Figure 4: Weekday Peak Hour Net Project Trip Assignment (Study Intersections)





LEGEND	
#	Study Intersection
#	Site Access
↑	Peak Hour Net Project Trips
XX	Non-Truck
(XX)	(Truck)
Trip Distribution	
⊖	Non-Truck
⊕	Truck

AM Peak Hour

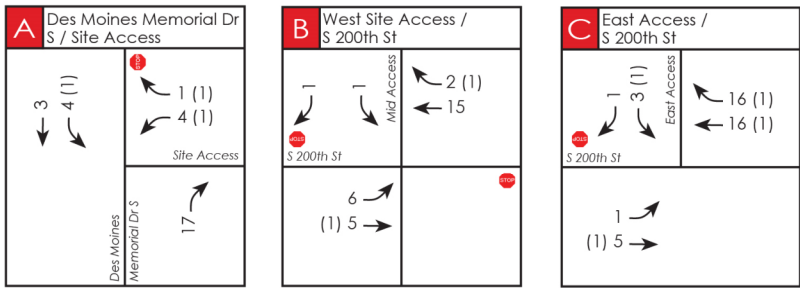

Afternoon Peak Hour

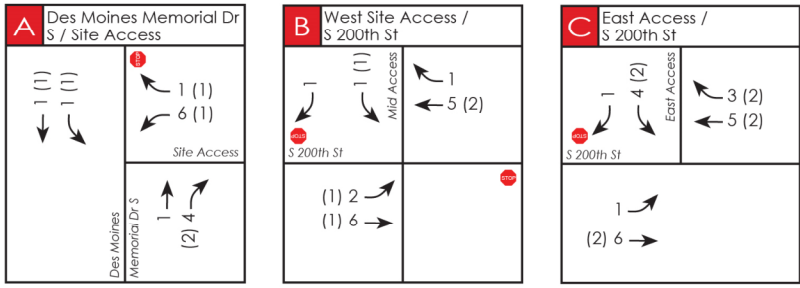

PM Peak Hour

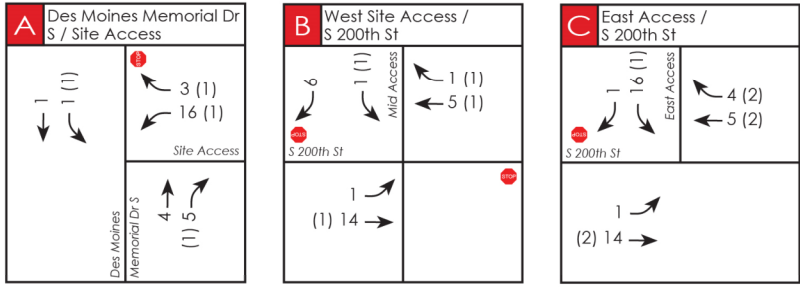

*Note: Trips entering/ exiting site access driveways are gross project trips.

Figure 5: Weekday Peak Hour Project Trip Assignment (Site Driveways)



Future Traffic Volumes

Future year 2023 Without-Project peak hour traffic volumes were estimated by applying a 2 percent annual background growth rate to the adjusted 2021 existing traffic volumes. The 2 percent annual growth rate was determined to be appropriate based on conversations with the City during the Traffic Scoping process. It should be noted that the future 2023 traffic volumes include the vacation of S 196th Street and 18th Avenue S between Des Moines Memorial Drive S and S 200th Street. Traffic volumes on S 196th Street and 18th Avenue S were re-assigned through the study intersection of Des Moines Memorial Drive S/S 200th Street. The resulting future 2023 without-project weekday peak hour traffic volumes at the study intersections are shown in **Figure 6**.

The 2023 With-Project traffic volumes were determined by adding the trip assignment from the proposed development (shown in **Figures 4 and 5**) to the future 2023 Without-Project traffic volumes. The resulting future 2023 With-Project weekday peak hour traffic volumes at the study intersections and site driveways are shown in **Figures 7 and 8**.

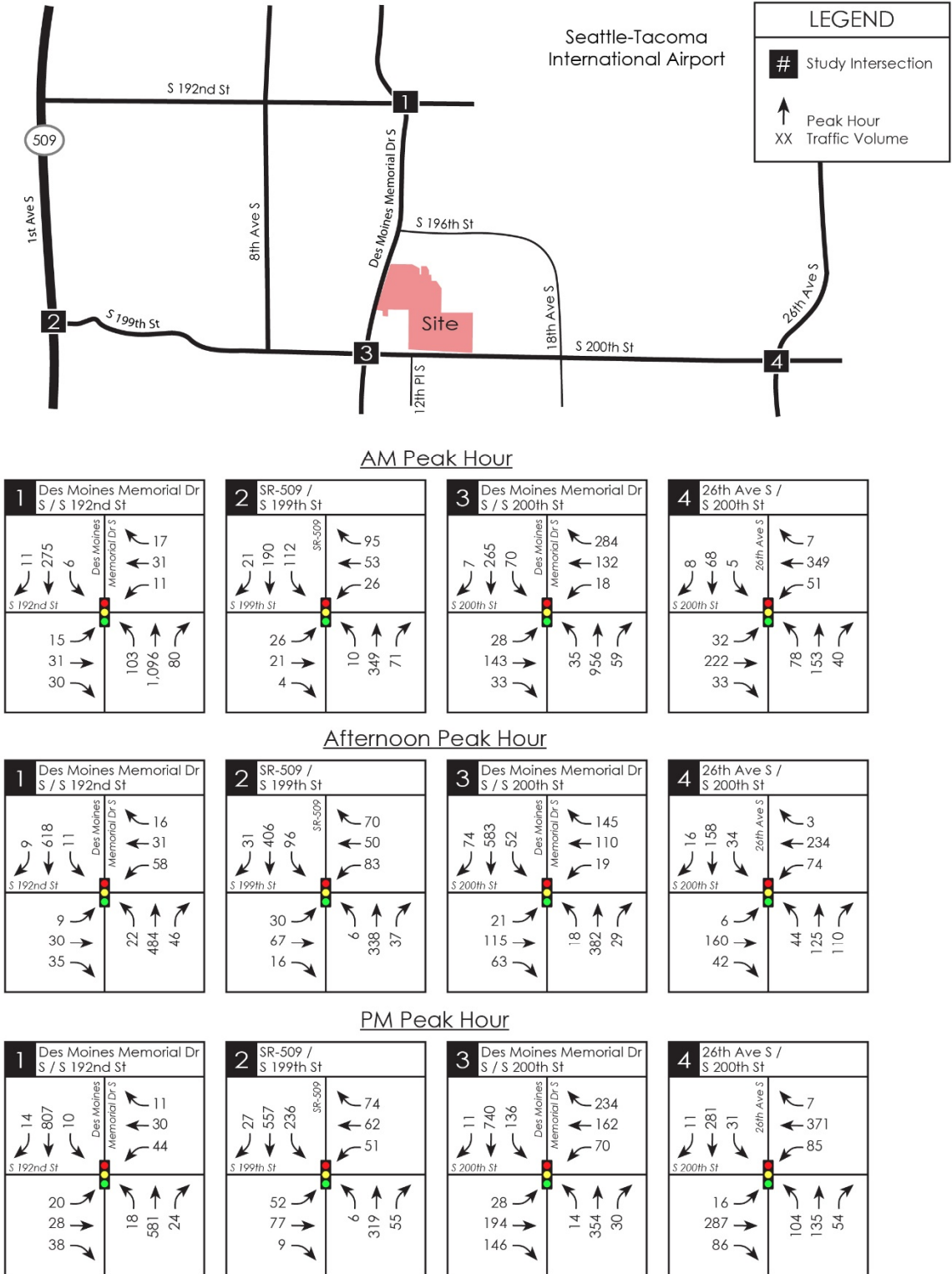

Figure 6: 2023 Without Project Weekday Peak Hour Traffic Volumes



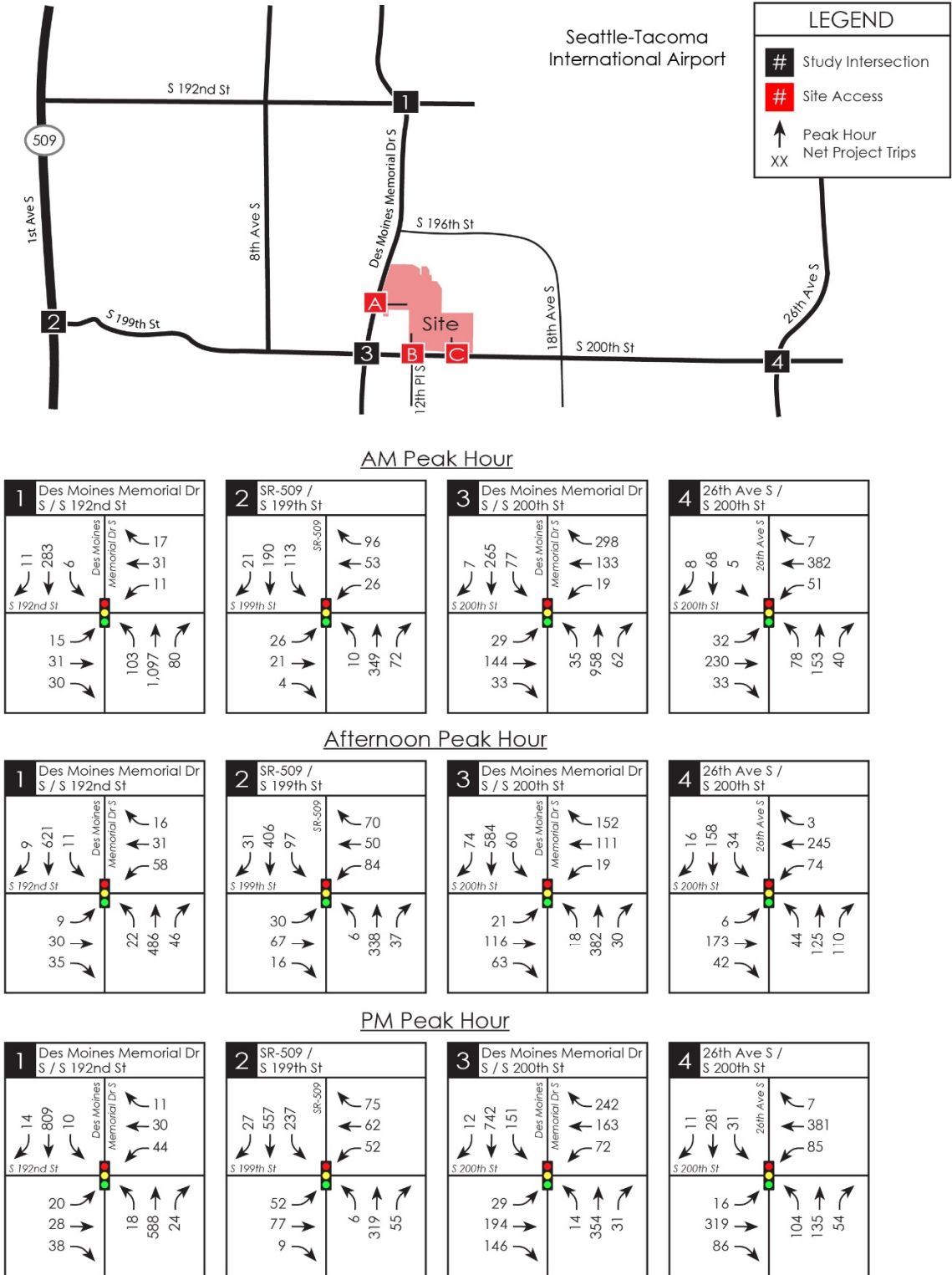
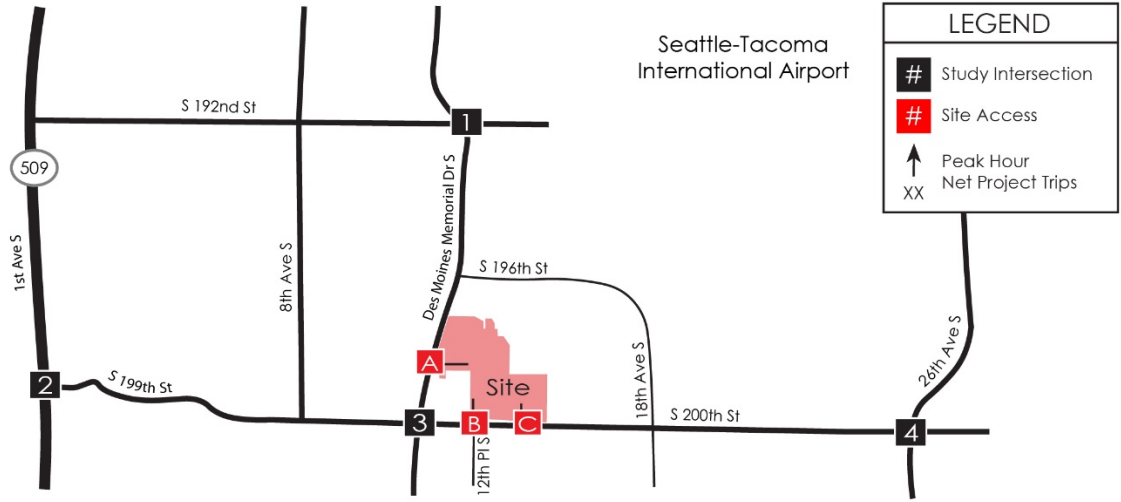
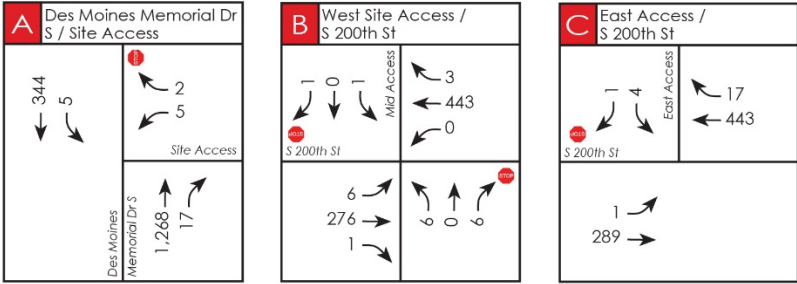

Figure 7: 2023 With Project Weekday Peak Hour Traffic Volumes (Study Intersections)





AM Peak Hour



Afternoon Peak Hour

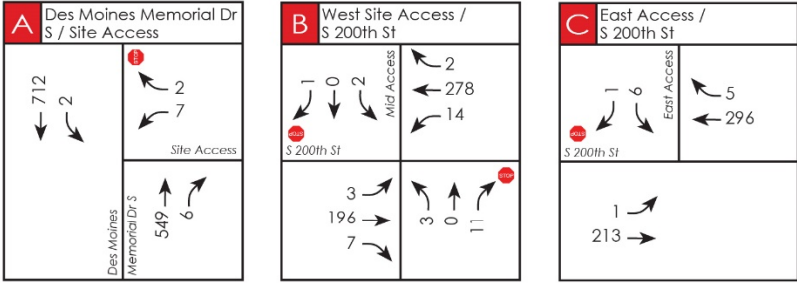

PM Peak Hour

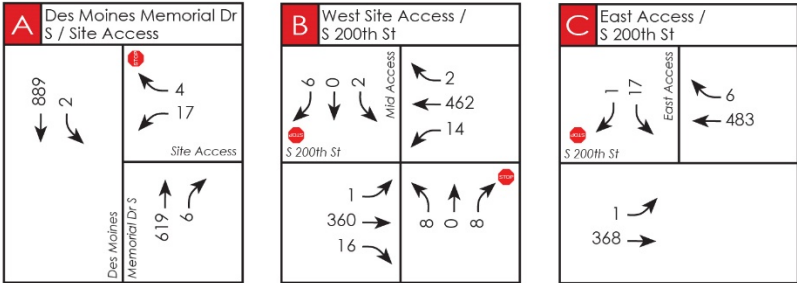

Figure 8: 2023 With Project Weekday Peak Hour Traffic Volumes (Site Driveways)



Future Level of Service

Future year 2023 Level of Service (LOS) analyses were conducted at the four offsite study intersections for weekday AM, afternoon, and PM peak hour without-project and with-project conditions. Existing intersection geometry and signal timing was assumed at the study intersections as there are no City-planned improvements that are expected to be complete by 2023.

The 2023 weekday peak hour LOS results at the study intersections without and with the proposed project are summarized in **Table 5**. The detailed LOS worksheets are included in **Appendix B**.

Table 5
Year 2023 Peak Hour LOS Summary

Study Intersection	2023 Without Project		2023 With Project	
	LOS ¹	Delay (sec) ²	LOS ¹	Delay (sec) ²
<i>AM Peak Hour</i>				
1. Des Moines Memorial Drive S / S 192nd St	D	41.2	D	41.2
2. 1st Ave S (SR 509) / S 199th St	B	14.1	B	14.1
3. Des Moines Memorial Drive S / S 200th St	E	69.6	E	74.3
4. 26th Avenue S / S 200th St	B	11.0	B	11.2
<i>Afternoon Peak Hour</i>				
1. Des Moines Memorial Drive S / S 192nd St	B	15.7	B	15.7
2. 1st Ave S (SR 509) / S 199th St	B	13.5	B	13.6
3. Des Moines Memorial Drive S / S 200th St	C	23.4	C	23.7
4. 26th Avenue S / S 200th St	B	11.0	B	11.0
<i>PM Peak Hour</i>				
1. Des Moines Memorial Drive S / S 192nd St	B	15.2	B	15.2
2. 1st Ave S (SR 509) / S 199th St	B	14.1	B	14.2
3. Des Moines Memorial Drive S / S 200th St	C	28.6	C	28.8
4. 26th Avenue S / S 200th St	B	11.7	B	11.8

1. LOS = Level of Service

2. Delay refers to average control delay expressed in seconds per vehicle.

As shown in **Table 5** the study intersections are anticipated to operate at an acceptable LOS E or better during the weekday AM, afternoon, and PM peak hours in 2023 without or with the proposed project.

Site Access Analysis

Level of service analyses were conducted at the proposed site accesses on S 200th Street and Des Moines Memorial Drive S for 2023 With-Project traffic conditions for the weekday AM, afternoon, and PM peak hours. The LOS analyses were conducted based on the methodology and procedures outlined in the 6th Edition of the *Highway Capacity Manual* (HCM) using the *Synchro 10.3* software program. The 2023 With-Project peak hour volumes at the site access location used in the LOS analyses are shown in **Figure 6**.

The weekday AM, afternoon, and PM peak hour LOS results at the site access location for 2023 With-Project conditions are summarized in **Table 6**. The LOS worksheets are included in **Appendix B**.

Table 6
Year 2023 Peak Hour Level of Service Summary at Site Access Locations

Proposed Driveway	AM Peak Hour			Afternoon Peak Hour			PM Peak Hour		
	LOS ¹	Delay (sec) ²	V/C ³	LOS ¹	Delay (sec) ²	V/C ³	LOS ¹	Delay (sec) ²	V/C ³
A. Site Access / Des Moines Memorial Drive S									
WB Shared Left-Right	E	47.6	0.08	D	26.9	0.06	E	40.5	0.18
SB Left Turn	B	13.3	0.01	A	9.6	0.00	A	10.0	0.00
B. West Site Access (12th Pl S) / S 200th St									
NB Shared Left-Thru-Right	C	15.5	0.04	B	10.3	0.02	C	16.0	0.05
EB Left Turn	A	8.6	0.01	A	8.3	0.00	A	8.4	0.00
WB Left Turn	A	0.0	0.00	A	7.7	0.01	A	8.2	0.01
SB Shared Left-Thru-Right	C	16.2	0.01	B	13.4	0.01	B	14.7	0.02
C. East Site Access / S 200th St									
EB Left Turn	A	8.4	0.00	A	7.9	0.00	A	8.4	0.00
SB Shared Left-Right	C	15.7	0.02	B	12.8	0.02	C	17.9	0.07

1. LOS = Level of Service
2. Delay refers to average control delay expressed in seconds per vehicle.
3. V/C = Volume/capacity ratio.

As shown in **Table 6**, the results of the LOS analyses show that all controlled movements at the proposed site access driveways are anticipated to operate at LOS E or better during the weekday peak hours. Based on the reported LOS A for the entering left-turn movements at the proposed site access driveways, the project impacts to S 200th Street and Des Moines Memorial Drive S (which each currently has one-travel lane in each direction) is not anticipated to be significant.

Non-Motorized Transportation Impacts

The project is not anticipated to have a significant impact on the non-motorized bicycle and pedestrian facilities in the project vicinity. The planned *S 200th Street Shared Use Path* will be located on the south side of S 200th Street adjacent to the project site which is anticipated to minimize

potential pedestrian/ vehicle conflicts along S 200th Street at the proposed site driveway locations. The *S 200th Street Shared Use Path* is currently under construction and is anticipated to be completed later this year.

MITIGATION

Frontage/Access Improvements

S 200th Street

- Half-street improvements including 6-foot sidewalk, 4-foot planter, curb and gutter, 5-foot bike lane, and 11-foot travel lane.

Des Moines Memorial Drive S

- Potential 2 ft to 6 ft right-of-way dedication.

Off-Site Improvements

Based on the results of the analysis shown in this report, no project-specific off-site transportation mitigation is proposed for concurrency or SEPA purposes.

Transportation Impact Fees

Payment of the City of SeaTac transportation impact fee will mitigate project-related transportation impacts of the proposed warehouse project. The payment of transportation impact fees will mitigate project-related transportation impacts. Transportation impact fees will be determined by the City of SeaTac and will need to be paid at the time of a building permit issuance. As of the date of this study, the adopted City of SeaTac 2021 impact fee schedule identifies a fee of \$709 per 1,000 square feet for Warehousing and \$3,730 for Single Family Detached Housing.

Appendix A

Peak Hour Turning Movement Counts

DES MOINES MEMORIAL DR S 200TH ST



Peak Hour

Date: Tue, Apr 11, 2017
Count Period: 7:00 AM to 9:00 AM
Peak Hour: 7:00 AM to 8:00 AM

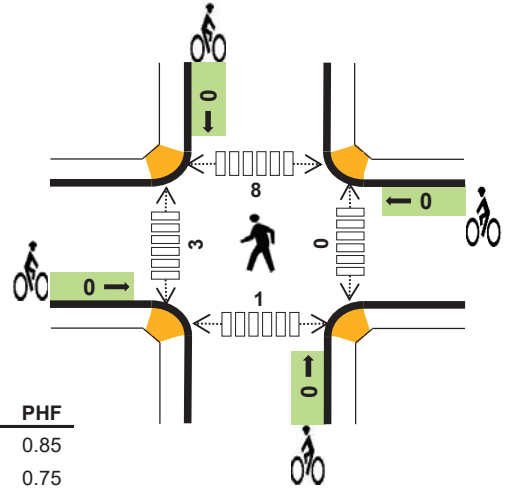
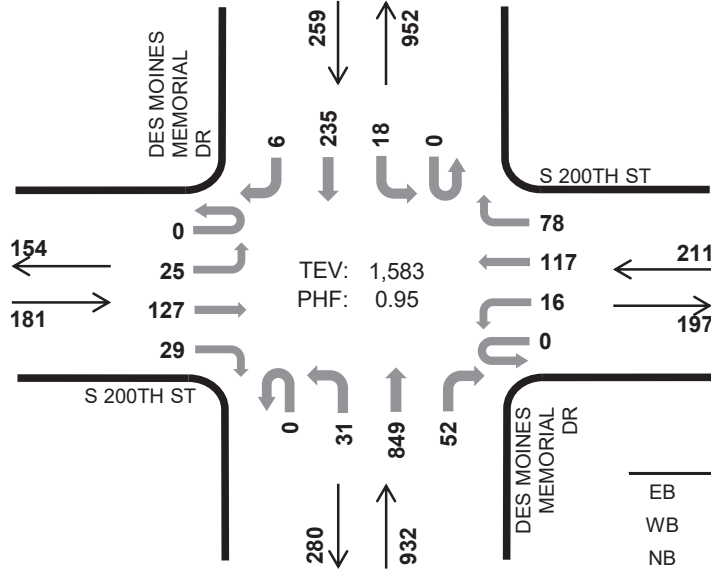

	HV %:	PHF
EB	2.8%	0.85
WB	3.3%	0.75
NB	0.6%	0.94
SB	1.2%	0.91
TOTAL	1.3%	0.95

Two-Hour Count Summaries

Interval Start	S 200TH ST				S 200TH ST				DES MOINES MEMORIAL DR				DES MOINES MEMORIAL DR				15-min Total	Rolling One Hour
	Eastbound		Westbound		Northbound		Southbound		UT		LT		TH		RT			
7:00 AM	0	6	29	1	0	3	22	14	0	3	228	17	0	4	54	0	381	0
7:15 AM	0	3	35	5	0	4	27	23	0	12	221	9	0	4	54	2	399	0
7:30 AM	0	9	33	11	0	5	38	27	0	9	202	13	0	5	64	2	418	0
7:45 AM	0	7	30	12	0	4	30	14	0	7	198	13	0	5	63	2	385	1,583
8:00 AM	0	7	24	6	1	5	27	14	0	9	165	12	0	6	40	1	317	1,519
8:15 AM	0	5	20	7	0	5	16	19	0	12	176	8	0	6	50	1	325	1,445
8:30 AM	0	8	20	11	0	5	18	17	0	9	140	6	0	14	68	1	317	1,344
8:45 AM	0	10	32	19	0	6	39	22	0	20	114	8	0	8	67	1	346	1,305
Count Total	0	55	223	72	1	37	217	150	0	81	1,444	86	0	52	460	10	2,888	0
Peak Hour	0	25	127	29	0	16	117	78	0	31	849	52	0	18	235	6	1,583	0

Note: Two-hour count summary volumes include heavy vehicles but exclude bicycles in overall count.

Interval Start	Heavy Vehicle Totals					Bicycles					Pedestrians (Crossing Leg)				
	EB	WB	NB	SB	Total	EB	WB	NB	SB	Total	East	West	North	South	Total
7:00 AM	0	4	2	1	7	0	0	0	0	0	0	0	1	1	2
7:15 AM	1	0	1	1	3	0	0	0	0	0	0	0	2	0	2
7:30 AM	2	1	0	0	3	0	0	0	0	0	0	2	5	0	7
7:45 AM	2	2	3	1	8	0	0	0	0	0	0	1	0	0	1
8:00 AM	1	0	2	1	4	0	0	0	0	0	0	0	0	0	0
8:15 AM	1	0	2	0	3	0	0	0	0	0	0	0	0	0	0
8:30 AM	1	1	0	0	2	0	0	0	0	0	0	0	0	0	0
8:45 AM	1	1	2	0	4	0	0	0	0	0	0	0	1	0	1
Count Total	9	9	12	4	34	0	0	0	0	0	0	3	9	1	13
Peak Hour	5	7	6	3	21	0	0	0	0	0	0	3	8	1	12



ALL TRAFFIC DATA SERVICES

(303) 216-2439

www.alltrafficdata.net

Location: 2 SR 509 & S 199TH ST AM

Date: Thursday, February 4, 2021

Peak Hour: 08:00 AM - 09:00 AM

Peak Hour

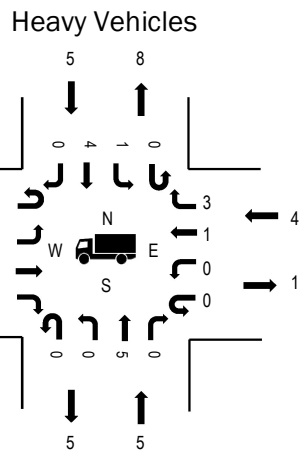
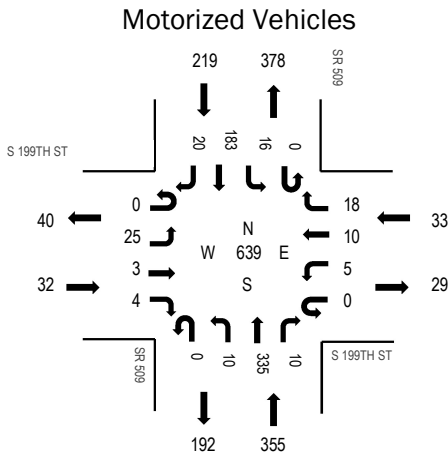

Pedestrians/Bicycles in Crosswalk

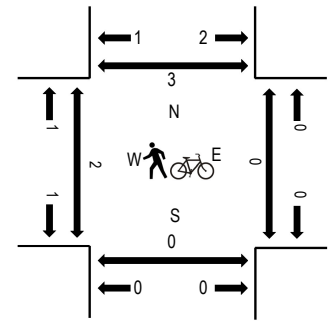

	HV%	PHF
EB	3.1%	0.62
WB	12.1%	0.83
NB	1.4%	0.85
SB	2.3%	0.84
All	2.3%	0.87

Traffic Counts - Motorized Vehicles

Interval Start Time	S 199TH ST Eastbound				S 199TH ST Westbound				SR 509 Northbound				SR 509 Southbound				Total	Rolling Hour
	U-Turn	Left	Thru	Right	U-Turn	Left	Thru	Right	U-Turn	Left	Thru	Right	U-Turn	Left	Thru	Right		
7:00 AM	0	6	0	2	0	3	0	6	0	2	70	2	0	2	28	1	122	534
7:15 AM	0	2	0	0	0	1	4	9	0	1	73	0	0	2	30	2	124	557
7:30 AM	0	2	0	0	0	0	3	13	0	0	89	1	1	1	34	1	145	587
7:45 AM	0	5	0	0	0	1	1	3	0	2	92	2	0	2	33	2	143	598
8:00 AM	0	4	1	0	0	2	2	5	0	1	70	2	0	3	55	0	145	639
8:15 AM	0	3	1	1	0	2	2	6	0	3	88	4	0	6	34	4	154	
8:30 AM	0	10	0	3	0	1	2	5	0	3	79	1	0	4	43	5	156	
8:45 AM	0	8	1	0	0	0	4	2	0	3	98	3	0	3	51	11	184	
Count Total	0	40	3	6	0	10	18	49	0	15	659	15	1	23	308	26	1,173	
Peak Hour	0	25	3	4	0	5	10	18	0	10	335	10	0	16	183	20	639	

Traffic Counts - Heavy Vehicles and Pedestrians/Bicycles in Crosswalk

Interval Start Time	Heavy Vehicles					Interval Start Time	Pedestrians/Bicycles on Crosswalk				
	EB	NB	WB	SB	Total		EB	NB	WB	SB	Total
7:00 AM	0	1	0	1	2	7:00 AM	0	0	0	0	0
7:15 AM	0	1	0	1	2	7:15 AM	2	0	0	0	2
7:30 AM	0	3	0	1	4	7:30 AM	1	0	0	0	1
7:45 AM	0	1	0	0	1	7:45 AM	0	0	1	0	1
8:00 AM	0	1	0	2	3	8:00 AM	0	0	0	1	1
8:15 AM	0	1	1	1	3	8:15 AM	1	0	0	1	2
8:30 AM	1	0	3	1	5	8:30 AM	1	0	0	1	2
8:45 AM	0	3	0	1	4	8:45 AM	0	0	0	0	0
Count Total	1	11	4	8	24	Count Total	5	0	1	3	9
Peak Hour	1	5	4	5	15	Peak Hour	2	0	0	3	5

Peak Hour

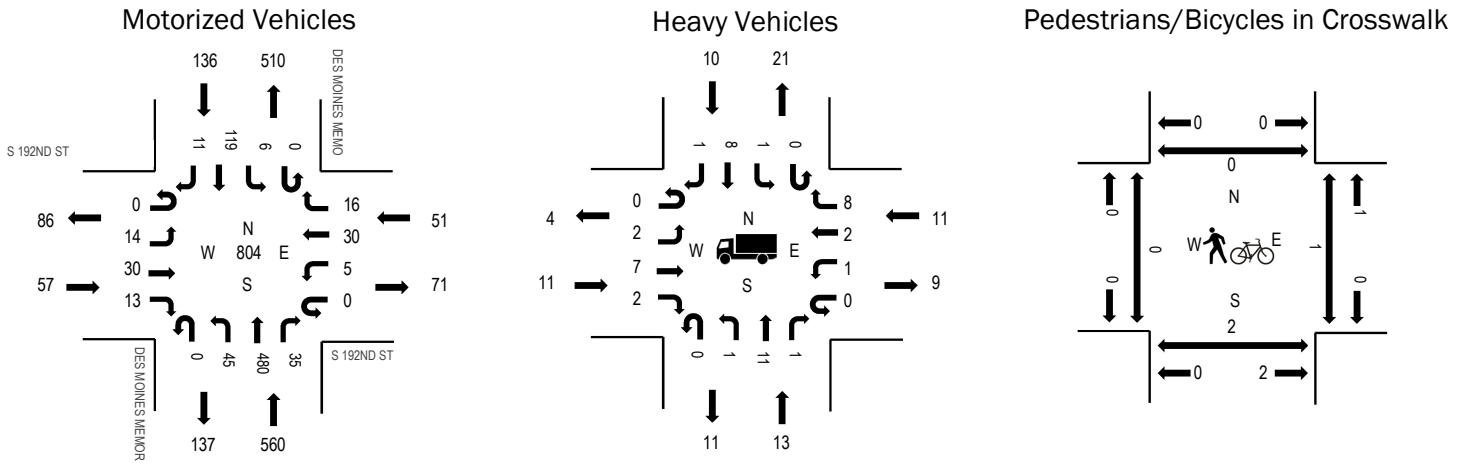

	HV%	PHF
EB	19.3%	0.75
WB	21.6%	0.67
NB	2.3%	0.89
SB	7.4%	0.83
All	5.6%	0.92

Traffic Counts - Motorized Vehicles

Interval Start Time	S 192ND ST Eastbound				S 192ND ST Westbound				DES MOINES MEMORIAL DR Northbound				DES MOINES MEMORIAL DR Southbound				Total	Rolling Hour
	U-Turn	Left	Thru	Right	U-Turn	Left	Thru	Right	U-Turn	Left	Thru	Right	U-Turn	Left	Thru	Right		
7:00 AM	0	2	3	2	0	2	4	4	0	17	116	9	0	0	28	4	191	804
7:15 AM	0	7	6	5	0	1	15	3	0	12	128	5	0	1	25	3	211	788
7:30 AM	0	1	13	5	0	0	4	3	0	11	135	12	0	3	27	4	218	733
7:45 AM	0	4	8	1	0	2	7	6	0	5	101	9	0	2	39	0	184	663
8:00 AM	0	1	9	3	0	8	7	0	0	3	107	6	0	2	28	1	175	637
8:15 AM	0	2	1	2	0	4	2	3	0	3	98	9	0	2	27	3	156	
8:30 AM	0	5	6	5	0	4	4	0	0	3	76	12	0	0	30	3	148	
8:45 AM	0	2	1	4	0	2	9	0	0	12	76	5	0	0	44	3	158	
Count Total	0	24	47	27	0	23	52	19	0	66	837	67	0	10	248	21	1,441	
Peak Hour	0	14	30	13	0	5	30	16	0	45	480	35	0	6	119	11	804	

Traffic Counts - Heavy Vehicles and Pedestrians/Bicycles in Crosswalk

Interval Start Time	Heavy Vehicles					Interval Start Time	Pedestrians/Bicycles on Crosswalk				
	EB	NB	WB	SB	Total		EB	NB	WB	SB	Total
7:00 AM	2	3	4	2	11	7:00 AM	0	0	0	0	0
7:15 AM	2	2	4	5	13	7:15 AM	0	1	1	0	2
7:30 AM	5	5	2	2	14	7:30 AM	0	1	0	0	1
7:45 AM	2	3	1	1	7	7:45 AM	0	0	0	0	0
8:00 AM	4	4	0	7	15	8:00 AM	0	0	0	0	0
8:15 AM	0	3	2	1	6	8:15 AM	0	0	0	0	0
8:30 AM	8	5	0	3	16	8:30 AM	0	0	3	0	3
8:45 AM	0	4	3	5	12	8:45 AM	0	0	0	0	0
Count Total	23	29	16	26	94	Count Total	0	2	4	0	6
Peak Hour	11	13	11	10	45	Peak Hour	0	2	1	0	3



(303) 216-2439
www.alltrafficdata.net

Location: 4 26TH AVE S & S 200TH ST AM

Date: Thursday, February 4, 2021

Peak Hour: 07:15 AM - 08:15 AM

Peak Hour

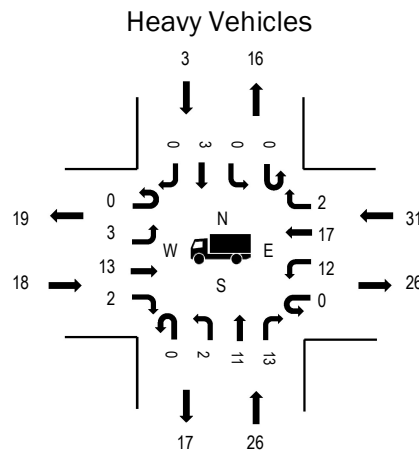
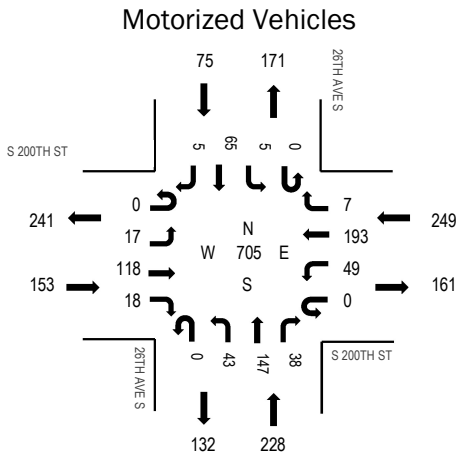

Pedestrians/Bicycles in Crosswalk

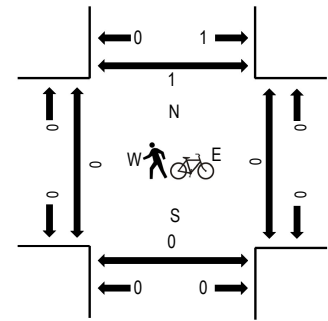

	HV%	PHF
EB	11.8%	0.75
WB	12.4%	0.90
NB	11.4%	0.83
SB	4.0%	0.85
All	11.1%	0.96

Traffic Counts - Motorized Vehicles

Interval Start Time	S 200TH ST Eastbound				S 200TH ST Westbound				26TH AVE S Northbound				26TH AVE S Southbound				Total	Rolling Hour
	U-Turn	Left	Thru	Right	U-Turn	Left	Thru	Right	U-Turn	Left	Thru	Right	U-Turn	Left	Thru	Right		
7:00 AM	0	1	27	10	0	18	36	1	0	22	31	7	0	0	13	1	167	689
7:15 AM	0	1	33	3	0	10	58	1	0	8	35	9	0	1	14	1	174	705
7:30 AM	0	2	30	4	0	12	46	0	0	13	48	8	0	2	16	1	182	701
7:45 AM	0	6	20	3	0	13	46	4	0	14	29	13	0	1	17	0	166	682
8:00 AM	0	8	35	8	0	14	43	2	0	8	35	8	0	1	18	3	183	688
8:15 AM	0	2	32	7	0	21	35	1	0	13	33	5	0	0	17	4	170	
8:30 AM	0	4	34	1	0	23	37	0	0	8	34	5	0	0	15	2	163	
8:45 AM	0	4	30	7	0	16	43	1	0	4	27	20	0	1	18	1	172	
Count Total	0	28	241	43	0	127	344	10	0	90	272	75	0	6	128	13	1,377	
Peak Hour	0	17	118	18	0	49	193	7	0	43	147	38	0	5	65	5	705	

Traffic Counts - Heavy Vehicles and Pedestrians/Bicycles in Crosswalk

Interval Start Time	Heavy Vehicles					Interval Start Time	Pedestrians/Bicycles on Crosswalk				
	EB	NB	WB	SB	Total		EB	NB	WB	SB	Total
7:00 AM	6	7	3	0	16	7:00 AM	0	0	0	0	0
7:15 AM	4	6	10	1	21	7:15 AM	0	0	0	0	0
7:30 AM	2	6	4	1	13	7:30 AM	0	0	0	0	0
7:45 AM	4	5	10	0	19	7:45 AM	0	0	0	1	1
8:00 AM	8	9	7	1	25	8:00 AM	0	0	0	0	0
8:15 AM	7	5	14	4	30	8:15 AM	0	0	0	0	0
8:30 AM	4	4	12	4	24	8:30 AM	0	0	0	0	0
8:45 AM	7	4	3	2	16	8:45 AM	0	1	0	0	1
Count Total	42	46	63	13	164	Count Total	0	1	0	1	2
Peak Hour	18	26	31	3	78	Peak Hour	0	0	0	1	1



(303) 216-2439
www.alltrafficdata.net

Location: 5 13TH AVE S & S 200TH ST AM

Date: Thursday, February 4, 2021

Peak Hour: 08:00 AM - 09:00 AM

Peak Hour

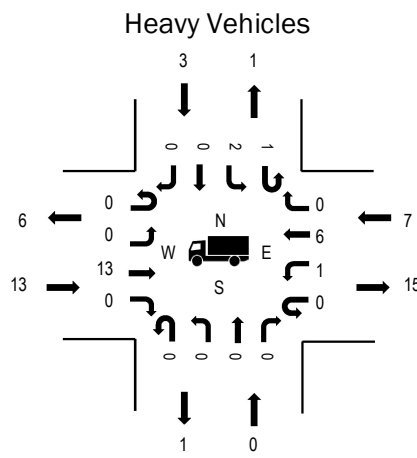
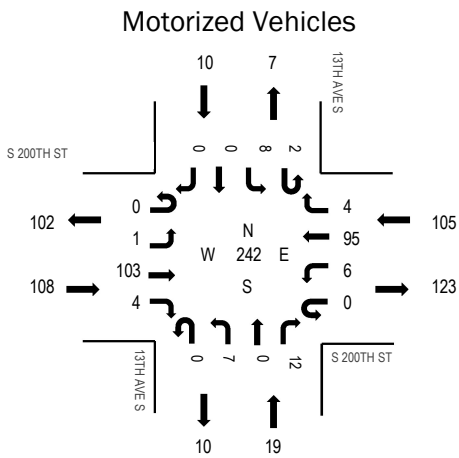

Pedestrians/Bicycles in Crosswalk

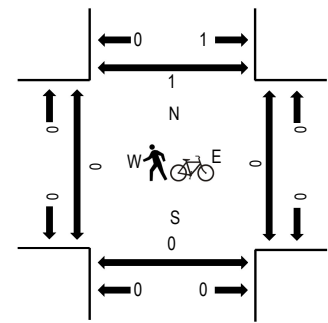

	HV%	PHF
EB	12.0%	0.90
WB	6.7%	0.82
NB	0.0%	0.79
SB	30.0%	0.63
All	9.5%	0.93

Traffic Counts - Motorized Vehicles

Interval Start Time	S 200TH ST Eastbound				S 200TH ST Westbound				13TH AVE S Northbound				13TH AVE S Southbound				Total	Rolling Hour
	U-Turn	Left	Thru	Right	U-Turn	Left	Thru	Right	U-Turn	Left	Thru	Right	U-Turn	Left	Thru	Right		
7:00 AM	0	0	31	0	0	0	37	2	0	2	0	1	0	0	0	0	73	238
7:15 AM	0	0	24	1	0	1	35	1	0	3	0	2	0	3	0	0	70	230
7:30 AM	0	0	21	0	0	1	26	3	0	2	0	1	0	3	0	0	57	224
7:45 AM	0	1	17	1	0	0	15	1	0	1	0	2	0	0	0	0	38	225
8:00 AM	0	0	25	1	0	3	28	1	0	2	0	4	0	1	0	0	65	242
8:15 AM	0	1	22	2	0	2	29	1	0	2	0	3	0	2	0	0	64	
8:30 AM	0	0	29	1	0	0	20	1	0	1	0	2	2	2	0	0	58	
8:45 AM	0	0	27	0	0	1	18	1	0	2	0	3	0	3	0	0	55	
Count Total	0	2	196	6	0	8	208	11	0	15	0	18	2	14	0	0	480	
Peak Hour	0	1	103	4	0	6	95	4	0	7	0	12	2	8	0	0	242	

Traffic Counts - Heavy Vehicles and Pedestrians/Bicycles in Crosswalk

Interval Start Time	Heavy Vehicles					Interval Start Time	Pedestrians/Bicycles on Crosswalk				
	EB	NB	WB	SB	Total		EB	NB	WB	SB	Total
7:00 AM	5	0	2	0	7	7:00 AM	0	0	0	0	0
7:15 AM	2	0	1	1	4	7:15 AM	0	0	0	0	0
7:30 AM	1	0	2	1	4	7:30 AM	0	0	0	0	0
7:45 AM	1	0	0	0	1	7:45 AM	0	0	0	0	0
8:00 AM	4	0	1	0	5	8:00 AM	0	0	0	0	0
8:15 AM	4	0	4	1	9	8:15 AM	0	0	0	0	0
8:30 AM	3	0	0	1	4	8:30 AM	0	0	0	1	1
8:45 AM	2	0	2	1	5	8:45 AM	0	0	0	0	0
Count Total	22	0	12	5	39	Count Total	0	0	0	1	1
Peak Hour	13	0	7	3	23	Peak Hour	0	0	0	1	1



(303) 216-2439
www.alltrafficdata.net

Location: 6 12TH PL S & S 200TH ST AM

Date: Thursday, February 4, 2021

Peak Hour: 07:00 AM - 08:00 AM

Peak Hour

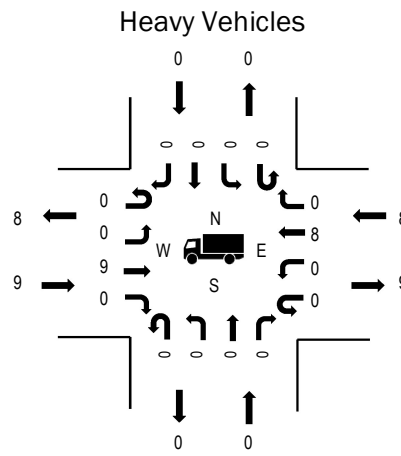
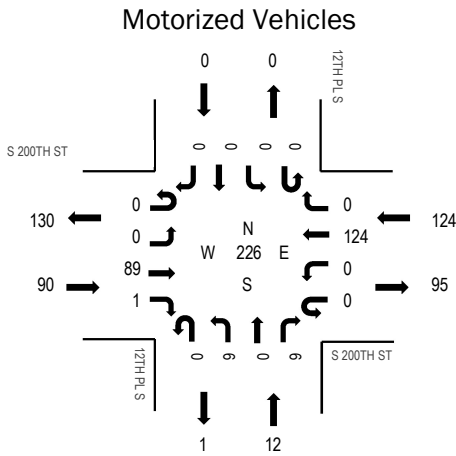

Pedestrians/Bicycles in Crosswalk

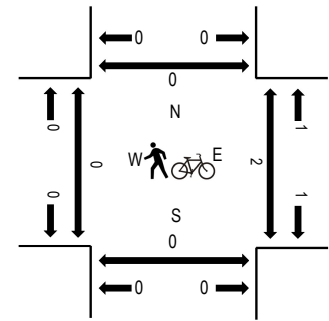

	HV%	PHF
EB	10.0%	0.78
WB	6.5%	0.78
NB	0.0%	0.60
SB	0.0%	0.00
All	7.5%	0.78

Traffic Counts - Motorized Vehicles

Interval Start Time	S 200TH ST Eastbound				S 200TH ST Westbound				12TH PL S Northbound				12TH PL S Southbound				Total	Rolling Hour
	U-Turn	Left	Thru	Right	U-Turn	Left	Thru	Right	U-Turn	Left	Thru	Right	U-Turn	Left	Thru	Right		
7:00 AM	0	0	29	0	0	0	40	0	0	1	0	2	0	0	0	0	72	226
7:15 AM	0	0	24	1	0	0	38	0	0	4	0	1	0	0	0	0	68	211
7:30 AM	0	0	17	0	0	0	30	0	0	0	0	3	0	0	0	0	50	202
7:45 AM	0	0	19	0	0	0	16	0	0	1	0	0	0	0	0	0	36	205
8:00 AM	0	0	24	0	0	1	29	0	0	2	0	1	0	0	0	0	57	216
8:15 AM	1	0	24	0	0	1	32	0	0	0	0	1	0	0	0	0	59	
8:30 AM	0	0	28	0	0	1	21	0	0	1	0	2	0	0	0	0	53	
8:45 AM	0	0	26	1	0	0	18	0	0	1	0	1	0	0	0	0	47	
Count Total	1	0	191	2	0	3	224	0	0	10	0	11	0	0	0	0	442	
Peak Hour	0	0	89	1	0	0	124	0	0	6	0	6	0	0	0	0	226	

Traffic Counts - Heavy Vehicles and Pedestrians/Bicycles in Crosswalk

Interval Start Time	Heavy Vehicles					Total	Interval Start Time	Pedestrians/Bicycles on Crosswalk					Total
	EB	NB	WB	SB				EB	NB	WB	SB		
7:00 AM	5	0	2	0	7	7	7:00 AM	0	0	0	0	0	0
7:15 AM	2	0	2	0	4	4	7:15 AM	0	0	0	0	0	0
7:30 AM	1	0	4	0	5	5	7:30 AM	0	0	0	0	0	0
7:45 AM	1	0	0	0	1	1	7:45 AM	0	0	2	0	2	2
8:00 AM	4	0	2	0	6	6	8:00 AM	0	0	0	0	0	0
8:15 AM	4	0	4	0	8	8	8:15 AM	0	0	0	0	0	0
8:30 AM	3	0	0	0	3	3	8:30 AM	0	0	0	1	1	1
8:45 AM	3	0	2	0	5	5	8:45 AM	0	0	0	0	0	0
Count Total	23	0	16	0	39	39	Count Total	0	0	2	1	3	3
Peak Hour	9	0	8	0	17	17	Peak Hour	0	0	2	0	2	2

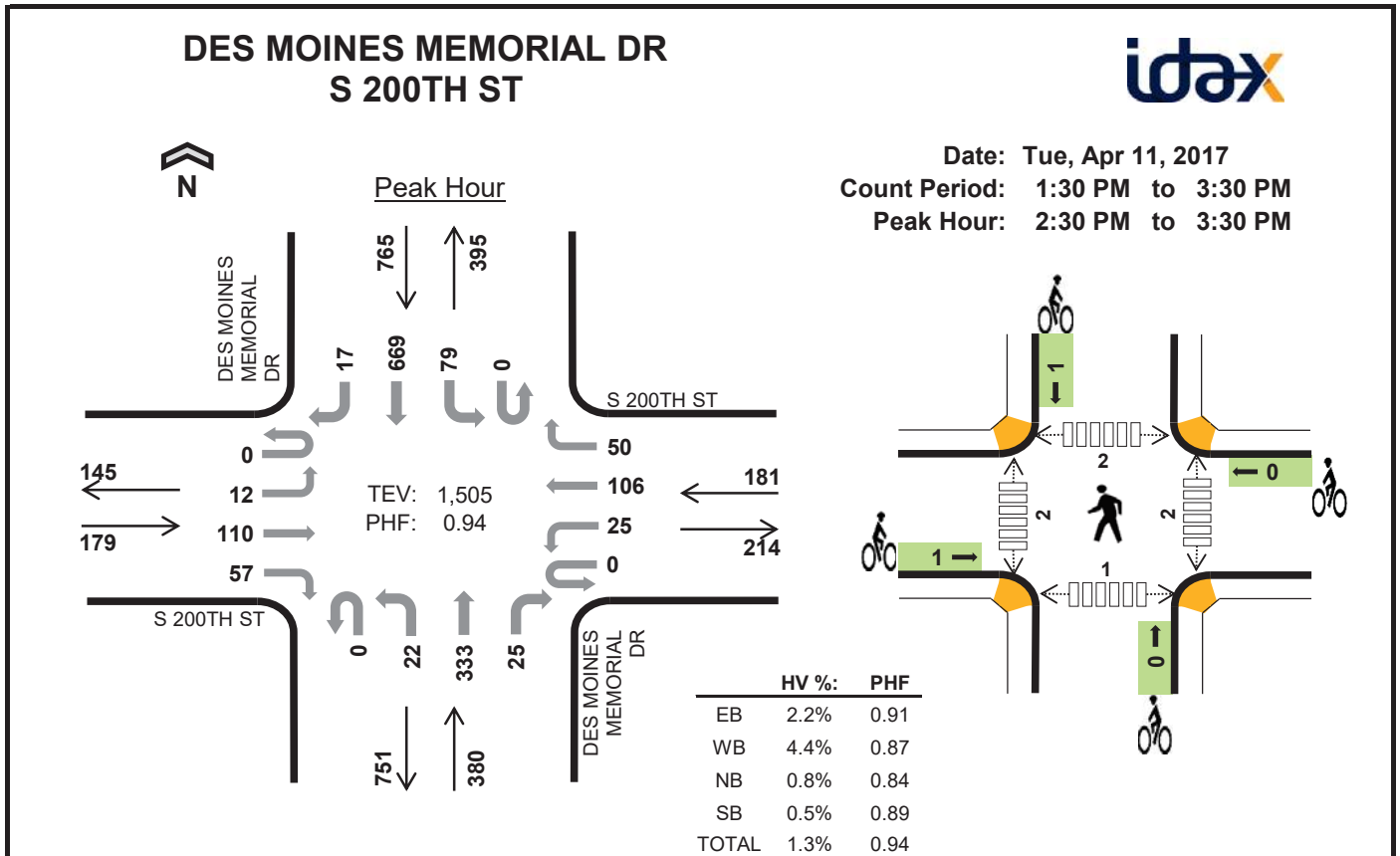

Two-Hour Count Summaries

Interval Start	S 200TH ST				S 200TH ST				DES MOINES MEMORIAL DR				DES MOINES MEMORIAL DR				15-min Total	Rolling One Hour
	Eastbound		Westbound		Northbound		Southbound		UT		LT		TH		RT			
1:30 PM	0	1	22	6	0	7	24	7	0	6	81	4	0	14	70	5	247	0
1:45 PM	0	3	22	14	0	12	33	8	0	7	78	4	0	14	96	6	297	0
2:00 PM	0	6	18	9	0	4	14	11	0	4	72	7	0	17	95	5	262	0
2:15 PM	0	5	27	16	0	3	26	10	0	3	89	7	0	17	114	1	318	1,124
2:30 PM	0	6	29	12	0	4	32	16	0	4	76	6	0	10	141	1	337	1,214
2:45 PM	0	2	28	19	0	6	26	14	0	5	102	6	0	22	168	3	401	1,318
3:00 PM	0	3	26	11	0	10	17	8	0	7	80	9	0	25	173	6	375	1,431
3:15 PM	0	1	27	15	0	5	31	12	0	6	75	4	0	22	187	7	392	1,505
Count Total	0	27	199	102	0	51	203	86	0	42	653	47	0	141	1,044	34	2,629	0
Peak Hour	0	12	110	57	0	25	106	50	0	22	333	25	0	79	669	17	1,505	0

Note: Two-hour count summary volumes include heavy vehicles but exclude bicycles in overall count.

Interval Start	Heavy Vehicle Totals					Bicycles					Pedestrians (Crossing Leg)				
	EB	WB	NB	SB	Total	EB	WB	NB	SB	Total	East	West	North	South	Total
1:30 PM	0	1	0	7	8	0	0	0	0	0	0	0	0	0	0
1:45 PM	2	1	3	10	16	0	0	0	0	0	0	1	1	1	3
2:00 PM	0	1	0	8	9	0	0	0	0	0	0	0	0	0	0
2:15 PM	1	3	7	5	16	1	1	0	0	2	0	0	0	0	1
2:30 PM	0	2	0	1	3	0	0	0	0	0	0	0	0	0	0
2:45 PM	2	2	1	1	6	0	0	0	0	0	1	1	0	0	2
3:00 PM	1	2	1	1	5	0	0	0	1	1	0	0	1	0	1
3:15 PM	1	2	1	1	5	1	0	0	0	1	1	1	1	1	4
Count Total	7	14	13	34	68	2	1	0	1	4	2	3	3	3	11
Peak Hour	4	8	3	4	19	1	0	0	1	2	2	2	2	1	7

Peak Hour

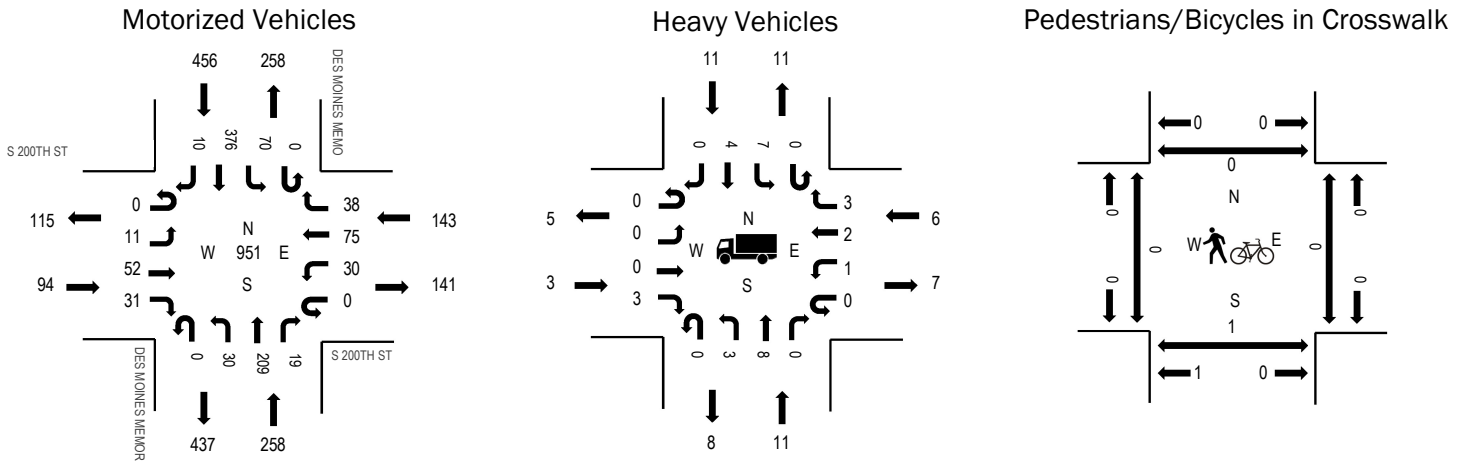

	HV%	PHF
EB	3.2%	0.73
WB	4.2%	0.87
NB	4.3%	0.90
SB	2.4%	0.79
All	3.3%	0.89

Traffic Counts - Motorized Vehicles

Interval Start Time	S 200TH ST Eastbound				S 200TH ST Westbound				DES MOINES MEMORIAL DR Northbound				DES MOINES MEMORIAL DR Southbound				Total	Rolling Hour
	U-Turn	Left	Thru	Right	U-Turn	Left	Thru	Right	U-Turn	Left	Thru	Right	U-Turn	Left	Thru	Right		
1:00 PM	0	2	11	4	0	6	16	6	0	4	51	7	0	8	58	3	176	729
1:15 PM	0	7	14	8	0	0	13	8	0	2	45	6	0	10	63	3	179	761
1:30 PM	0	5	22	9	0	6	12	7	0	5	48	5	0	8	43	3	173	814
1:45 PM	0	1	18	7	0	9	16	11	0	4	51	5	0	12	62	5	201	885
2:00 PM	0	7	12	4	0	7	17	10	0	6	57	4	0	10	71	3	208	951
2:15 PM	0	1	10	5	0	7	20	9	0	8	57	7	0	18	89	1	232	
2:30 PM	0	2	19	11	0	9	14	9	0	12	44	4	0	24	95	1	244	
2:45 PM	0	1	11	11	0	7	24	10	0	4	51	4	0	18	121	5	267	
Count Total	0	26	117	59	0	51	132	70	0	45	404	42	0	108	602	24	1,680	
Peak Hour	0	11	52	31	0	30	75	38	0	30	209	19	0	70	376	10	951	

Traffic Counts - Heavy Vehicles and Pedestrians/Bicycles in Crosswalk

Interval Start Time	Heavy Vehicles					Interval Start Time	Pedestrians/Bicycles on Crosswalk				
	EB	NB	WB	SB	Total		EB	NB	WB	SB	Total
1:00 PM	1	4	2	2	9	1:00 PM	0	0	0	0	0
1:15 PM	2	4	3	4	13	1:15 PM	0	0	0	0	0
1:30 PM	0	1	1	1	3	1:30 PM	0	0	0	0	0
1:45 PM	1	2	1	2	6	1:45 PM	1	2	0	0	3
2:00 PM	0	2	2	3	7	2:00 PM	0	0	0	0	0
2:15 PM	2	3	2	2	9	2:15 PM	0	1	0	0	1
2:30 PM	0	2	2	4	8	2:30 PM	0	0	0	0	0
2:45 PM	1	4	0	2	7	2:45 PM	0	0	0	0	0
Count Total	7	22	13	20	62	Count Total	1	3	0	0	4
Peak Hour	3	11	6	11	31	Peak Hour	0	1	0	0	1



ALL TRAFFIC DATA SERVICES

(303) 216-2439

www.alltrafficdata.net

Location: 2 SR 509 & S 199TH ST Noon

Date: Thursday, February 4, 2021

Peak Hour: 01:45 PM - 02:45 PM

Peak Hour

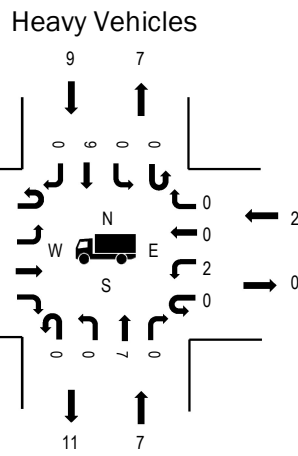
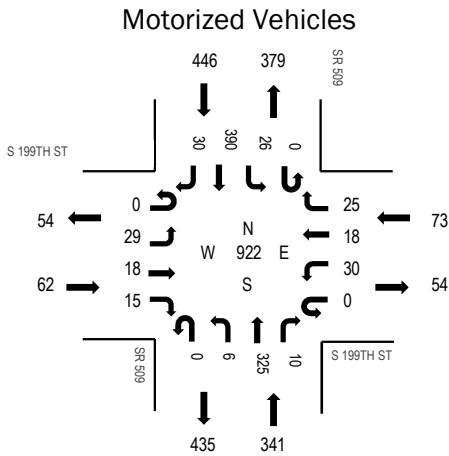

Pedestrians/Bicycles in Crosswalk

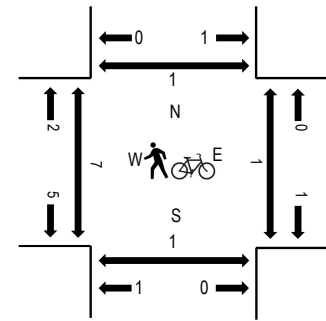

	HV%	PHF
EB	0.0%	0.65
WB	2.7%	0.83
NB	2.1%	0.85
SB	2.0%	0.82
All	2.0%	0.89

Traffic Counts - Motorized Vehicles

Interval Start Time	S 199TH ST Eastbound				S 199TH ST Westbound				SR 509 Northbound				SR 509 Southbound				Total	Rolling Hour
	U-Turn	Left	Thru	Right	U-Turn	Left	Thru	Right	U-Turn	Left	Thru	Right	U-Turn	Left	Thru	Right		
1:00 PM	0	6	6	5	0	4	4	7	0	7	65	2	0	7	83	7	203	860
1:15 PM	0	10	2	2	0	2	3	6	0	1	83	7	0	7	62	10	195	882
1:30 PM	0	6	1	2	0	3	3	9	0	1	102	1	0	9	91	8	236	899
1:45 PM	0	12	7	5	0	4	6	7	0	0	74	4	0	5	91	11	226	922
2:00 PM	0	5	6	3	0	10	6	6	0	1	77	0	0	5	99	7	225	914
2:15 PM	0	8	4	3	0	12	3	5	0	2	78	5	0	8	79	5	212	
2:30 PM	0	4	1	4	0	4	3	7	0	3	96	1	0	8	121	7	259	
2:45 PM	0	5	2	3	0	5	2	13	0	4	68	3	0	9	99	5	218	
Count Total	0	56	29	27	0	44	30	60	0	19	643	23	0	58	725	60	1,774	
Peak Hour	0	29	18	15	0	30	18	25	0	6	325	10	0	26	390	30	922	

Traffic Counts - Heavy Vehicles and Pedestrians/Bicycles in Crosswalk

Interval Start Time	Heavy Vehicles					Interval Start Time	Pedestrians/Bicycles on Crosswalk				
	EB	NB	WB	SB	Total		EB	NB	WB	SB	Total
1:00 PM	0	1	0	1	2	1:00 PM	1	0	1	0	2
1:15 PM	0	4	0	1	5	1:15 PM	0	0	0	0	0
1:30 PM	0	5	1	2	8	1:30 PM	1	0	0	0	1
1:45 PM	0	1	0	0	1	1:45 PM	4	0	0	0	4
2:00 PM	0	3	0	4	7	2:00 PM	2	1	1	1	5
2:15 PM	0	0	2	3	5	2:15 PM	0	0	0	0	0
2:30 PM	0	3	0	2	5	2:30 PM	1	0	0	0	1
2:45 PM	1	0	0	1	2	2:45 PM	2	0	0	1	3
Count Total	1	17	3	14	35	Count Total	11	1	2	2	16
Peak Hour	0	7	2	9	18	Peak Hour	7	1	1	1	10

Peak Hour

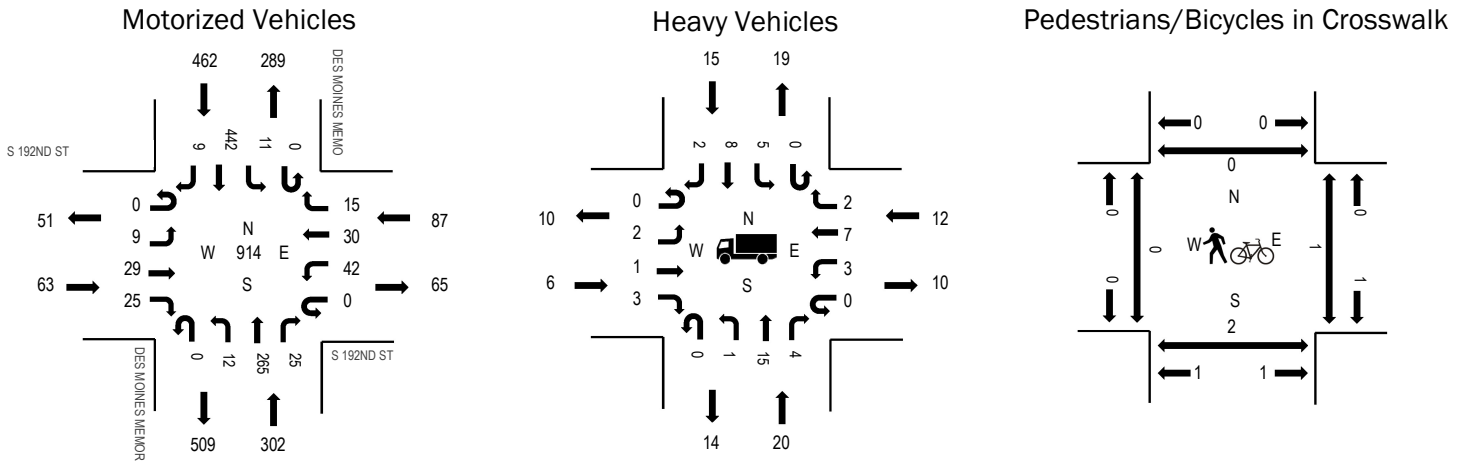

	HV%	PHF
EB	9.5%	0.79
WB	13.8%	0.75
NB	6.6%	0.96
SB	3.2%	0.74
All	5.8%	0.84

Traffic Counts - Motorized Vehicles

Interval Start Time	S 192ND ST Eastbound				S 192ND ST Westbound				DES MOINES MEMORIAL DR Northbound				DES MOINES MEMORIAL DR Southbound				Total	Rolling Hour
	U-Turn	Left	Thru	Right	U-Turn	Left	Thru	Right	U-Turn	Left	Thru	Right	U-Turn	Left	Thru	Right		
1:00 PM	0	4	5	6	0	11	5	3	0	5	56	7	0	3	71	5	181	738
1:15 PM	0	5	6	6	0	7	10	3	0	7	60	7	0	3	76	2	192	754
1:30 PM	0	3	10	2	0	7	6	2	0	2	70	5	0	0	72	1	180	797
1:45 PM	0	4	1	7	0	12	4	0	0	4	65	6	0	1	78	3	185	826
2:00 PM	0	1	7	5	0	9	9	2	0	3	66	10	0	4	78	3	197	914
2:15 PM	0	4	10	6	0	5	8	6	0	2	71	4	0	1	115	3	235	
2:30 PM	0	2	8	7	0	12	5	2	0	4	62	6	0	2	98	1	209	
2:45 PM	0	2	4	7	0	16	8	5	0	3	66	5	0	4	151	2	273	
Count Total	0	25	51	46	0	79	55	23	0	30	516	50	0	18	739	20	1,652	
Peak Hour	0	9	29	25	0	42	30	15	0	12	265	25	0	11	442	9	914	

Traffic Counts - Heavy Vehicles and Pedestrians/Bicycles in Crosswalk

Interval Start Time	Heavy Vehicles					Total	Interval Start Time	Pedestrians/Bicycles on Crosswalk					Total
	EB	NB	WB	SB				EB	NB	WB	SB		
1:00 PM	2	4	4	4	14	1:00 PM	0	0	0	0	0	0	
1:15 PM	3	7	2	7	19	1:15 PM	0	0	0	0	0	0	
1:30 PM	3	4	1	2	10	1:30 PM	0	0	0	0	0	0	
1:45 PM	2	2	1	4	9	1:45 PM	0	0	0	0	0	0	
2:00 PM	2	3	4	3	12	2:00 PM	0	0	0	0	0	0	
2:15 PM	3	5	1	4	13	2:15 PM	0	0	0	0	0	0	
2:30 PM	0	6	3	6	15	2:30 PM	0	2	1	0	3	3	
2:45 PM	1	6	4	2	13	2:45 PM	0	0	0	0	0	0	
Count Total	16	37	20	32	105	Count Total	0	2	1	0	3	3	
Peak Hour	6	20	12	15	53	Peak Hour	0	2	1	0	3	3	

Peak Hour

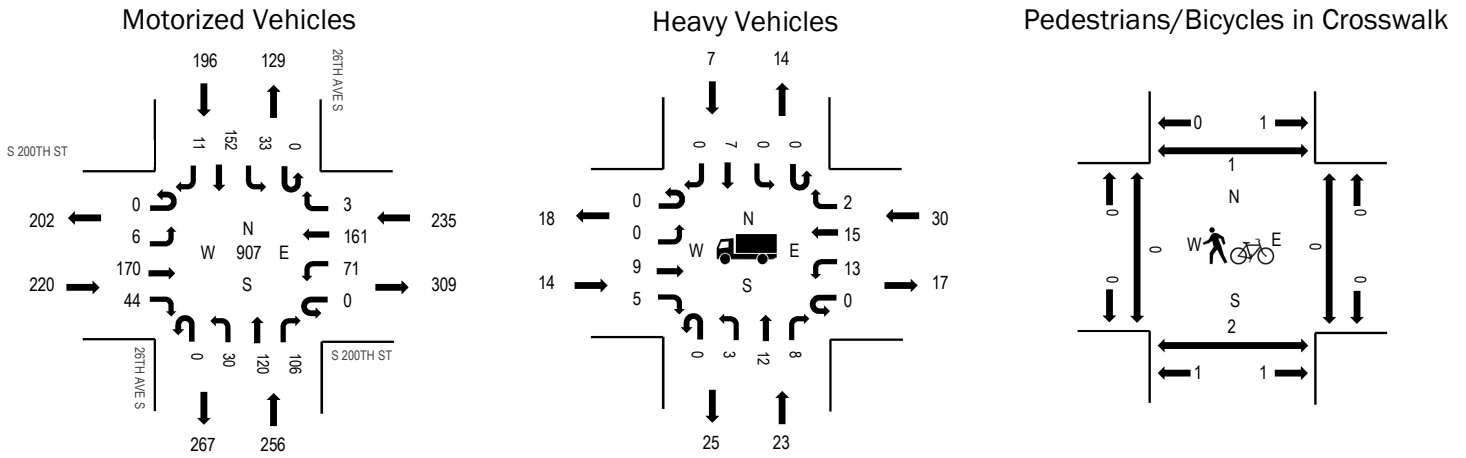

	HV%	PHF
EB	6.4%	0.86
WB	12.8%	0.93
NB	9.0%	0.88
SB	3.6%	0.79
All	8.2%	0.87

Traffic Counts - Motorized Vehicles

Interval Start Time	S 200TH ST Eastbound				S 200TH ST Westbound				26TH AVE S Northbound				26TH AVE S Southbound				Total	Rolling Hour
	U-Turn	Left	Thru	Right	U-Turn	Left	Thru	Right	U-Turn	Left	Thru	Right	U-Turn	Left	Thru	Right		
1:00 PM	0	2	38	5	0	15	46	4	0	8	31	16	0	6	24	2	197	777
1:15 PM	0	3	35	11	0	19	23	0	0	7	33	7	0	2	28	2	170	794
1:30 PM	0	2	46	4	0	21	41	2	0	13	33	14	0	4	15	3	198	823
1:45 PM	0	3	58	11	0	8	31	0	0	12	32	20	0	7	29	1	212	887
2:00 PM	0	1	29	10	0	14	45	0	0	5	32	35	0	8	32	3	214	907
2:15 PM	0	1	55	7	0	15	34	1	0	6	21	20	0	3	33	3	199	
2:30 PM	0	3	47	14	0	25	37	1	0	10	41	22	0	15	43	4	262	
2:45 PM	0	1	39	13	0	17	45	1	0	9	26	29	0	7	44	1	232	
Count Total	0	16	347	75	0	134	302	9	0	70	249	163	0	52	248	19	1,684	
Peak Hour	0	6	170	44	0	71	161	3	0	30	120	106	0	33	152	11	907	

Traffic Counts - Heavy Vehicles and Pedestrians/Bicycles in Crosswalk

Interval Start Time	Heavy Vehicles					Total	Interval Start Time	Pedestrians/Bicycles on Crosswalk					Total
	EB	NB	WB	SB	EB			NB	WB	SB			
1:00 PM	3	4	12	2	21	1:00 PM	0	0	0	1	1		
1:15 PM	4	5	6	3	18	1:15 PM	0	0	0	0	0		
1:30 PM	3	5	10	2	20	1:30 PM	0	1	0	1	2		
1:45 PM	4	4	5	3	16	1:45 PM	0	0	0	0	0		
2:00 PM	3	6	4	1	14	2:00 PM	0	0	0	0	0		
2:15 PM	3	4	7	0	14	2:15 PM	0	1	0	0	1		
2:30 PM	5	5	12	4	26	2:30 PM	0	1	0	1	2		
2:45 PM	3	8	7	2	20	2:45 PM	0	0	0	0	0		
Count Total	28	41	63	17	149	Count Total	0	3	0	3	6		
Peak Hour	14	23	30	7	74	Peak Hour	0	2	0	1	3		

Peak Hour

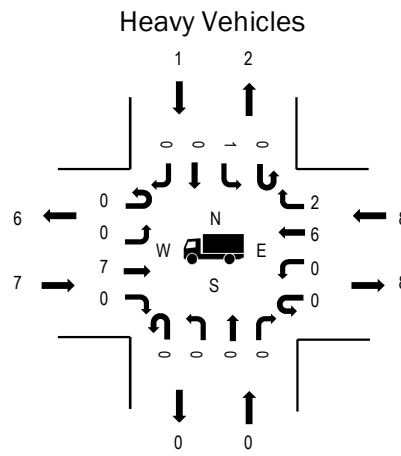
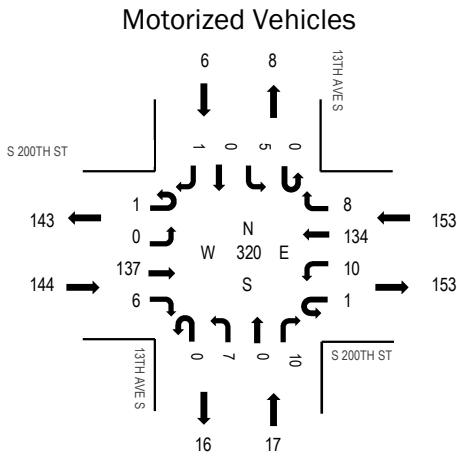

Pedestrians/Bicycles in Crosswalk

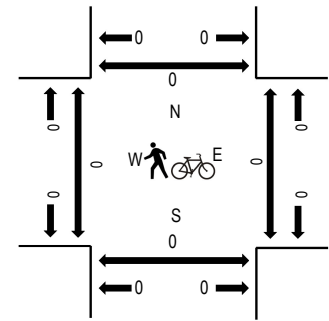

	HV%	PHF
EB	4.9%	0.77
WB	5.2%	0.93
NB	0.0%	0.71
SB	16.7%	0.50
All	5.0%	0.89

Traffic Counts - Motorized Vehicles

Interval Start Time	S 200TH ST Eastbound				S 200TH ST Westbound				13TH AVE S Northbound				13TH AVE S Southbound				Total	Rolling Hour	
	U-Turn	Left	Thru	Right	U-Turn	Left	Thru	Right	U-Turn	Left	Thru	Right	U-Turn	Left	Thru	Right			
1:00 PM	0	0	28	0	0	1	32	0	0	0	0	0	0	0	0	0	0	61	272
1:15 PM	0	0	30	2	0	1	24	0	0	0	0	6	0	2	0	0	0	65	282
1:30 PM	0	1	34	0	0	3	22	2	0	1	0	3	0	1	0	1	0	68	298
1:45 PM	0	0	33	1	0	1	32	2	0	3	0	3	0	3	0	0	0	78	320
2:00 PM	0	0	26	2	0	3	35	2	0	2	0	1	0	0	0	0	0	71	319
2:15 PM	0	0	34	1	0	2	37	2	0	1	0	1	0	2	0	1	0	81	
2:30 PM	1	0	44	2	1	4	30	2	0	1	0	5	0	0	0	0	0	90	
2:45 PM	0	0	30	1	0	1	40	0	0	1	0	3	0	1	0	0	0	77	
Count Total	1	1	259	9	1	16	252	10	0	9	0	22	0	9	0	2	0	591	
Peak Hour	1	0	137	6	1	10	134	8	0	7	0	10	0	5	0	1	0	320	

Traffic Counts - Heavy Vehicles and Pedestrians/Bicycles in Crosswalk

Interval Start Time	Heavy Vehicles					Interval Start Time	Pedestrians/Bicycles on Crosswalk				
	EB	NB	WB	SB	Total		EB	NB	WB	SB	Total
1:00 PM	1	0	2	0	3	1:00 PM	0	0	0	0	0
1:15 PM	4	0	5	0	9	1:15 PM	0	0	0	0	0
1:30 PM	0	0	2	0	2	1:30 PM	0	1	0	0	1
1:45 PM	1	0	1	0	2	1:45 PM	0	0	0	0	0
2:00 PM	2	0	2	0	4	2:00 PM	0	0	0	0	0
2:15 PM	1	0	3	1	5	2:15 PM	0	0	0	0	0
2:30 PM	3	0	2	0	5	2:30 PM	0	0	0	0	0
2:45 PM	1	0	0	0	1	2:45 PM	0	0	0	0	0
Count Total	13	0	17	1	31	Count Total	0	1	0	0	1
Peak Hour	7	0	8	1	16	Peak Hour	0	0	0	0	0

Peak Hour

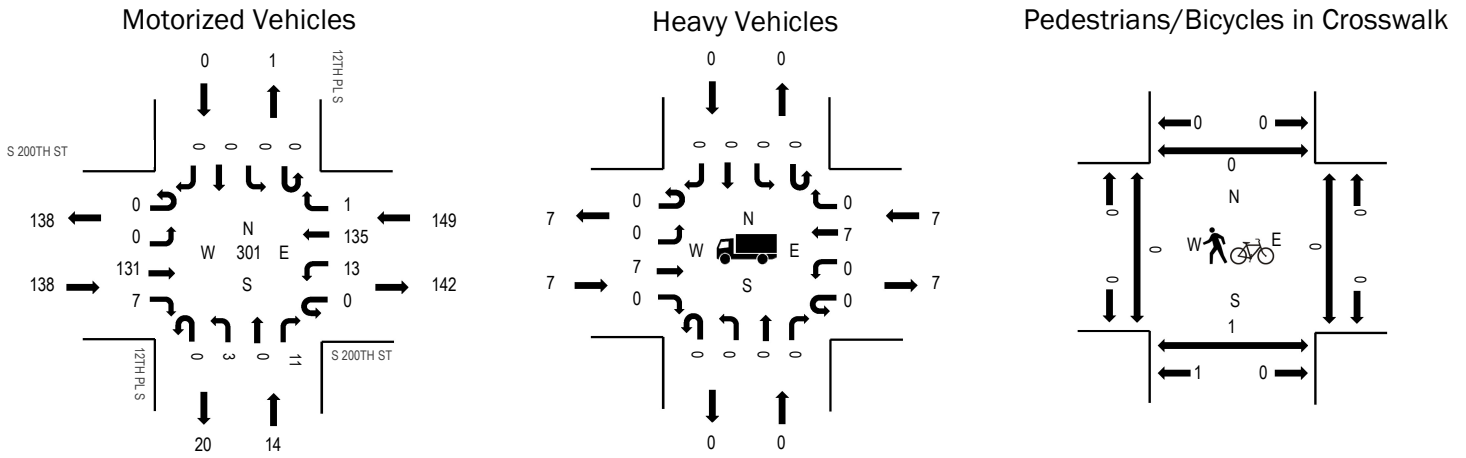

	HV%	PHF
EB	5.1%	0.75
WB	4.7%	0.89
NB	0.0%	0.70
SB	0.0%	0.00
All	4.7%	0.91

Traffic Counts - Motorized Vehicles

Interval Start Time	S 200TH ST Eastbound				S 200TH ST Westbound				12TH PL S Northbound				12TH PL S Southbound				Total	Rolling Hour
	U-Turn	Left	Thru	Right	U-Turn	Left	Thru	Right	U-Turn	Left	Thru	Right	U-Turn	Left	Thru	Right		
1:00 PM	0	0	27	0	0	3	29	0	0	0	0	1	0	0	0	0	60	246
1:15 PM	0	0	30	0	0	1	21	0	0	1	0	2	0	0	0	0	55	250
1:30 PM	0	0	33	0	0	2	23	0	0	2	0	1	0	0	0	0	61	274
1:45 PM	0	0	34	1	0	2	33	0	0	0	0	0	0	0	0	0	70	296
2:00 PM	0	0	25	0	0	3	33	0	0	0	0	3	0	0	0	0	64	301
2:15 PM	0	0	35	1	0	5	33	0	0	2	0	3	0	0	0	0	79	
2:30 PM	0	0	43	3	0	2	31	0	0	1	0	3	0	0	0	0	83	
2:45 PM	0	0	28	3	0	3	38	1	0	0	0	2	0	0	0	0	75	
Count Total	0	0	255	8	0	21	241	1	0	6	0	15	0	0	0	0	547	
Peak Hour	0	0	131	7	0	13	135	1	0	3	0	11	0	0	0	0	301	

Traffic Counts - Heavy Vehicles and Pedestrians/Bicycles in Crosswalk

Interval Start Time	Heavy Vehicles					Interval Start Time	Pedestrians/Bicycles on Crosswalk				
	EB	NB	WB	SB	Total		EB	NB	WB	SB	Total
1:00 PM	1	0	3	0	4	1:00 PM	0	0	0	0	0
1:15 PM	3	1	4	0	8	1:15 PM	0	0	0	0	0
1:30 PM	0	0	2	0	2	1:30 PM	0	1	1	0	2
1:45 PM	1	0	1	0	2	1:45 PM	0	0	0	0	0
2:00 PM	2	0	3	0	5	2:00 PM	0	0	0	0	0
2:15 PM	1	0	2	0	3	2:15 PM	0	1	0	0	1
2:30 PM	3	0	2	0	5	2:30 PM	0	0	0	0	0
2:45 PM	1	0	0	0	1	2:45 PM	0	0	0	0	0
Count Total	12	1	17	0	30	Count Total	0	2	1	0	3
Peak Hour	7	0	7	0	14	Peak Hour	0	1	0	0	1

Total Vehicle Summary



Clay Carney
(503) 833-2740

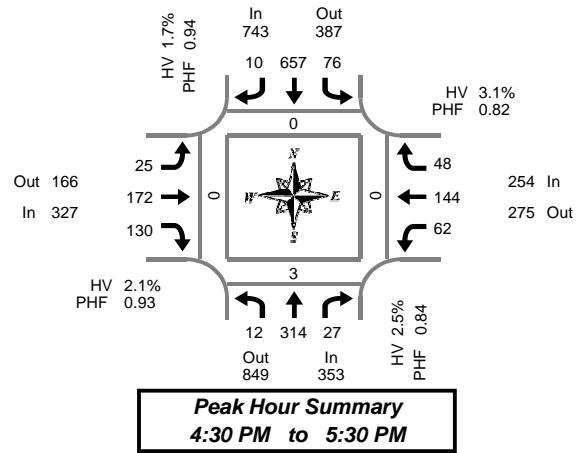

Des Moines Memorial Dr & S 200th St

Tuesday, August 08, 2017
4:00 PM to 6:00 PM

15-Minute Interval Summary 4:00 PM to 6:00 PM

Interval Start Time	Northbound Des Moines Memorial Dr				Southbound Des Moines Memorial Dr				Eastbound S 200th St				Westbound S 200th St				Interval Total	Pedestrians Crosswalk			
	L	T	R	Bikes	L	T	R	Bikes	L	T	R	Bikes	L	T	R	Bikes		North	South	East	West
4:00 PM	3	87	9	0	16	159	1	0	6	47	38	0	18	18	6	0	408	0	0	0	0
4:15 PM	4	73	5	0	14	152	5	0	2	47	33	0	10	30	15	0	390	0	1	0	1
4:30 PM	5	93	7	0	25	154	2	0	5	37	36	0	11	31	11	0	417	0	0	0	0
4:45 PM	4	78	9	0	17	177	4	0	6	40	30	0	13	39	9	0	426	0	0	0	0
5:00 PM	0	79	7	0	15	170	1	0	6	46	33	0	13	34	16	0	420	0	3	0	0
5:15 PM	3	64	4	0	19	156	3	0	8	49	31	0	25	40	12	0	414	0	0	0	0
5:30 PM	3	69	8	0	26	169	0	0	3	49	22	0	10	30	15	0	404	0	0	0	0
5:45 PM	4	75	13	0	27	136	6	0	4	34	31	0	26	47	5	0	408	0	0	0	0
Total Survey	26	618	62	0	159	1,273	22	0	40	349	254	0	126	269	89	0	3,287	0	4	0	1

Peak Hour Summary 4:30 PM to 5:30 PM

By Approach	Northbound Des Moines Memorial Dr				Southbound Des Moines Memorial Dr				Eastbound S 200th St				Westbound S 200th St				Total	Pedestrians Crosswalk			
	In	Out	Total	Bikes	In	Out	Total	Bikes	In	Out	Total	Bikes	In	Out	Total	Bikes		North	South	East	West
Volume	353	849	1,202	0	743	387	1,130	0	327	166	493	0	254	275	529	0	1,677	0	3	0	0
%HV	2.5%				1.7%				2.1%				3.1%				2.2%				
PHF	0.84				0.94				0.93				0.82				0.98				

By Movement	Northbound Des Moines Memorial Dr				Southbound Des Moines Memorial Dr				Eastbound S 200th St				Westbound S 200th St				Total
	L	T	R	Total	L	T	R	Total	L	T	R	Total	L	T	R	Total	
Volume	12	314	27	353	76	657	10	743	25	172	130	327	62	144	48	254	1,677
%HV	25.0%	1.6%	3.7%	2.5%	6.6%	1.2%	0.0%	1.7%	0.0%	0.6%	4.6%	2.1%	1.6%	3.5%	4.2%	3.1%	2.2%
PHF	0.60	0.84	0.75	0.84	0.76	0.93	0.63	0.94	0.78	0.88	0.90	0.93	0.62	0.90	0.75	0.82	0.98

Rolling Hour Summary 4:00 PM to 6:00 PM

Interval Start Time	Northbound Des Moines Memorial Dr				Southbound Des Moines Memorial Dr				Eastbound S 200th St				Westbound S 200th St				Interval Total	Pedestrians Crosswalk			
	L	T	R	Bikes	L	T	R	Bikes	L	T	R	Bikes	L	T	R	Bikes		North	South	East	West
4:00 PM	16	331	30	0	72	642	12	0	19	171	137	0	52	118	41	0	1,641	0	1	0	1
4:15 PM	13	323	28	0	71	653	12	0	19	170	132	0	47	134	51	0	1,653	0	4	0	1
4:30 PM	12	314	27	0	76	657	10	0	25	172	130	0	62	144	48	0	1,677	0	3	0	0
4:45 PM	10	290	28	0	77	672	8	0	23	184	116	0	61	143	52	0	1,664	0	3	0	0
5:00 PM	10	287	32	0	87	631	10	0	21	178	117	0	74	151	48	0	1,646	0	3	0	0

Heavy Vehicle Summary



Clay Carney
(503) 833-2740

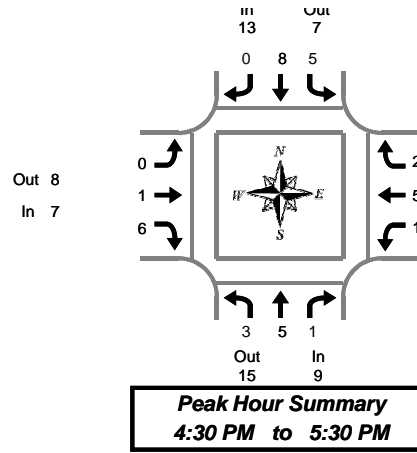

Des Moines Memorial Dr & S 200th St

Tuesday, August 08, 2017
4:00 PM to 6:00 PM

Heavy Vehicle 15-Minute Interval Summary 4:00 PM to 6:00 PM

Interval Start Time	Northbound Des Moines Memorial Dr				Southbound Des Moines Memorial Dr				Eastbound S 200th St				Westbound S 200th St				Interval Total
	L	T	R	Total	L	T	R	Total	L	T	R	Total	L	T	R	Total	
4:00 PM	0	0	0	0	1	3	0	4	0	1	1	2	0	1	0	1	7
4:15 PM	1	3	0	4	1	0	0	1	0	2	1	3	0	0	1	1	9
4:30 PM	1	2	1	4	2	3	0	5	0	0	2	2	0	3	0	3	14
4:45 PM	1	2	0	3	1	1	0	2	0	0	1	1	0	1	2	3	9
5:00 PM	0	1	0	1	0	2	0	2	0	0	1	1	0	1	0	1	5
5:15 PM	1	0	0	1	2	2	0	4	0	1	2	3	1	0	0	1	9
5:30 PM	0	0	0	0	1	1	0	2	0	0	0	0	0	0	1	1	3
5:45 PM	1	0	0	1	0	0	0	0	0	0	1	1	0	2	3	5	7
Total Survey	5	8	1	14	8	12	0	20	0	4	9	13	1	8	7	16	63

Heavy Vehicle Peak Hour Summary 4:30 PM to 5:30 PM

By Approach	Northbound Des Moines Memorial Dr			Southbound Des Moines Memorial Dr			Eastbound S 200th St			Westbound S 200th St			Total
	In	Out	Total	In	Out	Total	In	Out	Total	In	Out	Total	
Volume	9	15	24	13	7	20	7	8	15	8	7	15	37
PHF	0.20			0.33			0.25			0.29			0.29

By Movement	Northbound Des Moines Memorial Dr				Southbound Des Moines Memorial Dr				Eastbound S 200th St				Westbound S 200th St				Total
	L	T	R	Total	L	T	R	Total	L	T	R	Total	L	T	R	Total	
Volume	3	5	1	9	5	8	0	13	0	1	6	7	1	5	2	8	37
PHF	0.25	0.18	0.25	0.20	0.31	0.33	0.00	0.33	0.00	0.08	0.38	0.25	0.25	0.25	0.13	0.29	0.29

Heavy Vehicle Rolling Hour Summary 4:00 PM to 6:00 PM

Interval Start Time	Northbound Des Moines Memorial Dr				Southbound Des Moines Memorial Dr				Eastbound S 200th St				Westbound S 200th St				Interval Total
	L	T	R	Total	L	T	R	Total	L	T	R	Total	L	T	R	Total	
4:00 PM	3	7	1	11	5	7	0	12	0	3	5	8	0	5	3	8	39
4:15 PM	3	8	1	12	4	6	0	10	0	2	5	7	0	5	3	8	37
4:30 PM	3	5	1	9	5	8	0	13	0	1	6	7	1	5	2	8	37
4:45 PM	2	3	0	5	4	6	0	10	0	1	4	5	1	2	3	6	26
5:00 PM	2	1	0	3	3	5	0	8	0	1	4	5	1	3	4	8	24

Peak Hour Summary



Clay Carney
(503) 833-2740

Des Moines Memorial Dr & S 200th St

4:30 PM to 5:30 PM
Tuesday, August 08, 2017

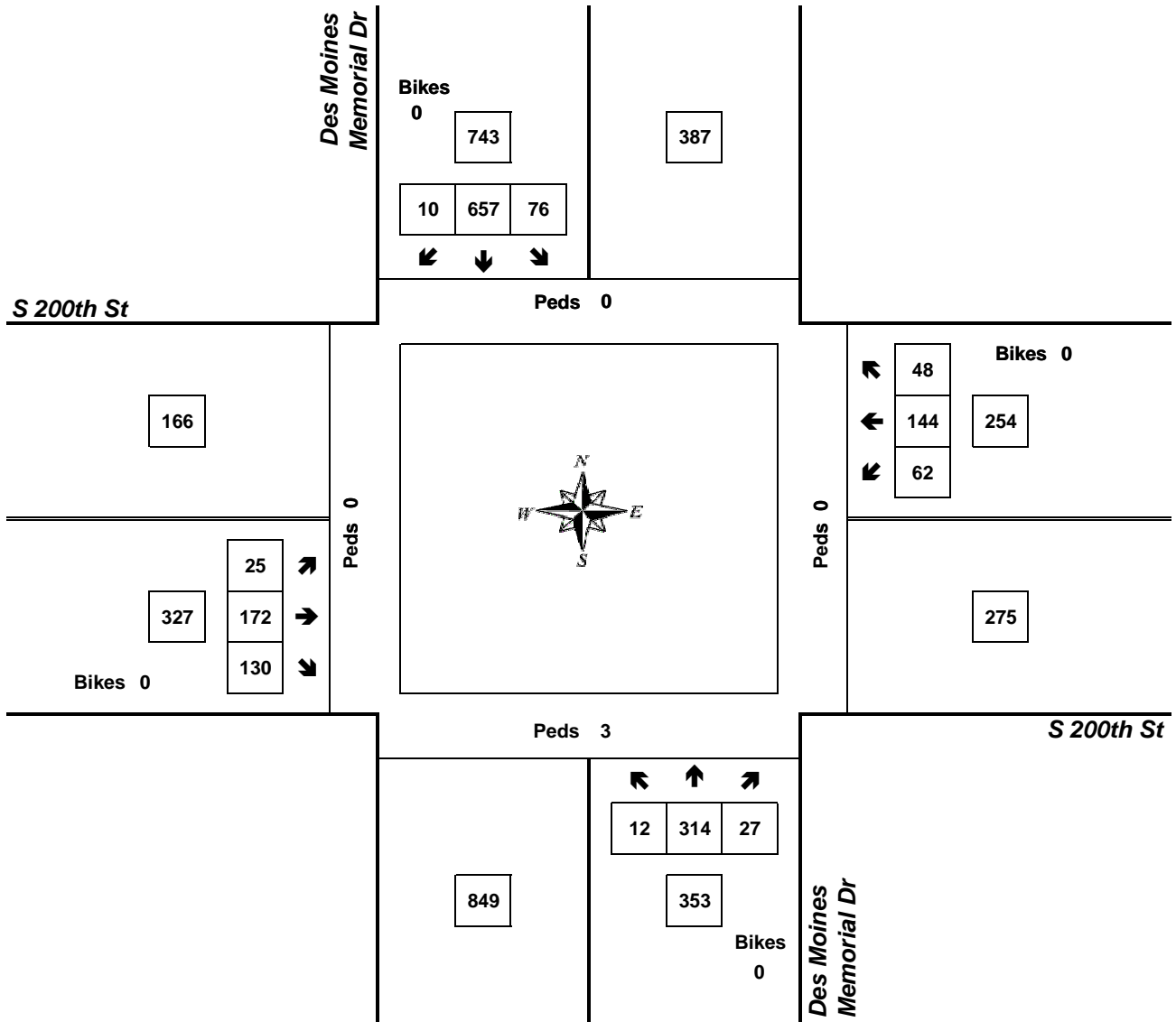

Approach	PHF	HV%	Volume
EB	0.93	2.1%	327
WB	0.82	3.1%	254
NB	0.84	2.5%	353
SB	0.94	1.7%	743
Intersection	0.98	2.2%	1,677

Count Period: 4:00 PM to 6:00 PM

Peak Hour

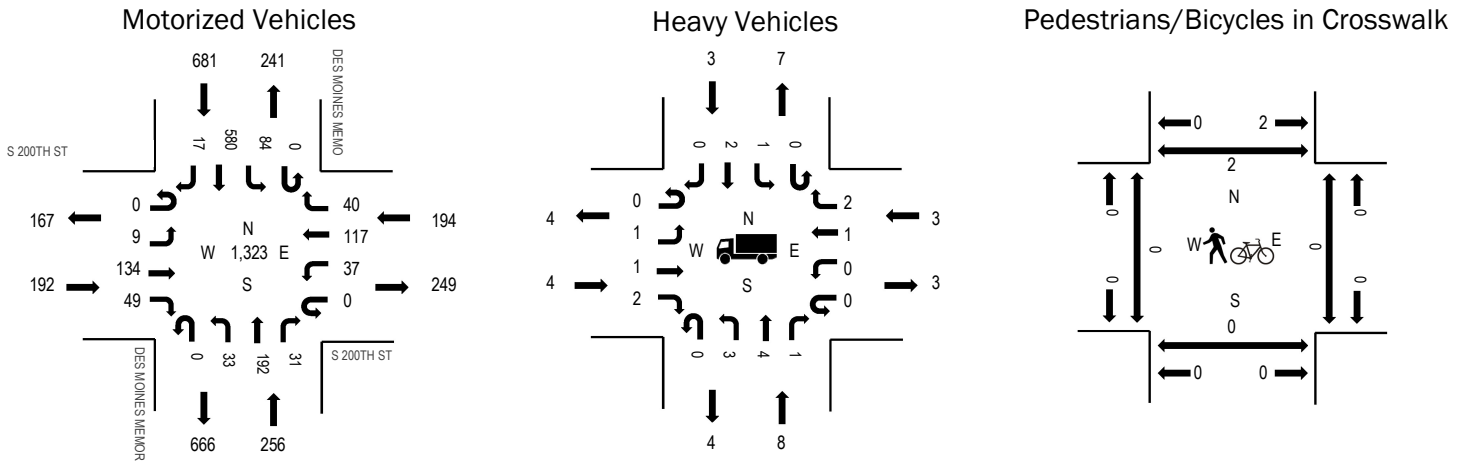

	HV%	PHF
EB	2.1%	0.83
WB	1.5%	0.90
NB	3.1%	0.89
SB	0.4%	0.92
All	1.4%	0.95

Traffic Counts - Motorized Vehicles

Interval Start Time	S 200TH ST Eastbound				S 200TH ST Westbound				DES MOINES MEMORIAL DR Northbound				DES MOINES MEMORIAL DR Southbound				Total	Rolling Hour
	U-Turn	Left	Thru	Right	U-Turn	Left	Thru	Right	U-Turn	Left	Thru	Right	U-Turn	Left	Thru	Right		
4:00 PM	0	3	28	9	0	8	11	12	0	3	58	3	0	22	131	4	292	1,274
4:15 PM	0	2	37	14	0	7	28	13	0	5	55	7	0	16	153	2	339	1,315
4:30 PM	0	3	39	12	0	5	31	10	0	7	41	8	0	23	149	4	332	1,323
4:45 PM	0	1	21	8	0	15	29	10	0	11	54	7	0	16	134	5	311	1,248
5:00 PM	0	3	40	15	0	6	28	13	0	3	55	6	0	21	141	2	333	1,200
5:15 PM	0	2	34	14	0	11	29	7	0	12	42	10	0	24	156	6	347	
5:30 PM	0	4	23	11	0	9	22	5	0	6	42	7	0	19	106	3	257	
5:45 PM	0	2	25	19	0	12	25	11	0	4	39	4	0	14	106	2	263	
Count Total	0	20	247	102	0	73	203	81	0	51	386	52	0	155	1,076	28	2,474	
Peak Hour	0	9	134	49	0	37	117	40	0	33	192	31	0	84	580	17	1,323	

Traffic Counts - Heavy Vehicles and Pedestrians/Bicycles in Crosswalk

Interval Start Time	Heavy Vehicles					Interval Start Time	Pedestrians/Bicycles on Crosswalk				
	EB	NB	WB	SB	Total		EB	NB	WB	SB	Total
4:00 PM	0	2	1	4	7	4:00 PM	0	0	0	1	1
4:15 PM	1	2	1	0	4	4:15 PM	0	0	0	0	0
4:30 PM	1	0	0	2	3	4:30 PM	0	0	0	0	0
4:45 PM	1	4	1	0	6	4:45 PM	0	0	0	0	0
5:00 PM	1	1	1	1	4	5:00 PM	0	0	0	0	0
5:15 PM	1	3	1	0	5	5:15 PM	0	0	0	2	2
5:30 PM	0	0	0	1	1	5:30 PM	0	0	0	0	0
5:45 PM	1	1	1	2	5	5:45 PM	0	1	0	1	2
Count Total	6	13	6	10	35	Count Total	0	1	0	4	5
Peak Hour	4	8	3	3	18	Peak Hour	0	0	0	2	2

Peak Hour

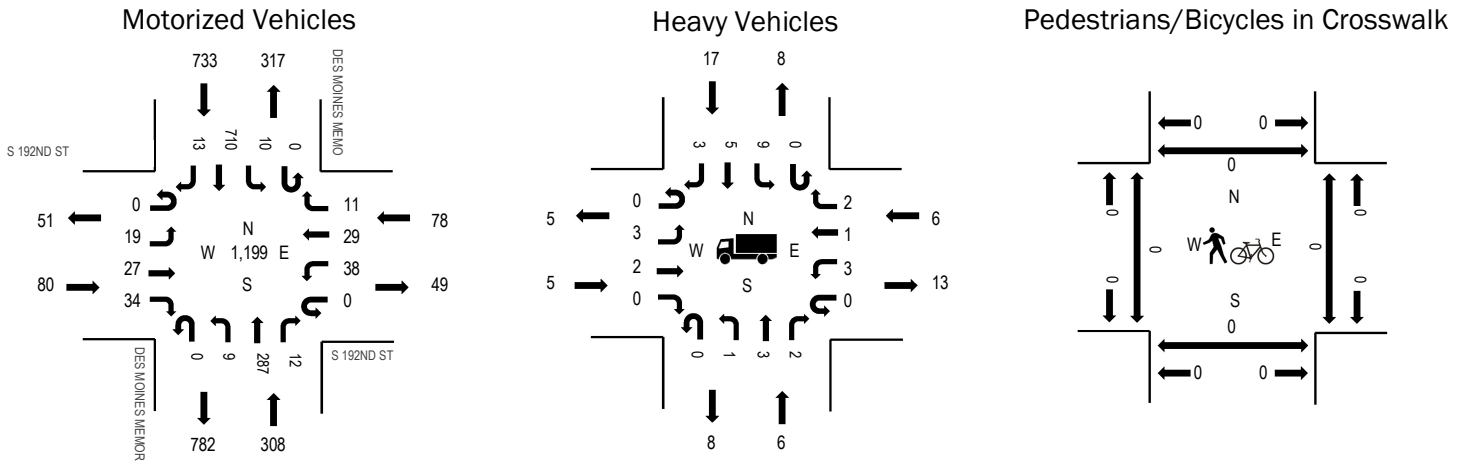

	HV%	PHF
EB	6.3%	0.74
WB	7.7%	0.81
NB	1.9%	0.91
SB	2.3%	0.96
All	2.8%	0.94

Traffic Counts - Motorized Vehicles

Interval Start Time	S 192ND ST Eastbound				S 192ND ST Westbound				DES MOINES MEMORIAL DR Northbound				DES MOINES MEMORIAL DR Southbound				Total	Rolling Hour
	U-Turn	Left	Thru	Right	U-Turn	Left	Thru	Right	U-Turn	Left	Thru	Right	U-Turn	Left	Thru	Right		
4:00 PM	0	3	4	8	0	10	7	4	0	4	69	3	0	7	168	0	287	1,185
4:15 PM	0	5	11	11	0	8	9	4	0	3	80	2	0	4	177	4	318	1,199
4:30 PM	0	3	6	8	0	18	4	2	0	1	61	3	0	3	183	4	296	1,156
4:45 PM	0	4	6	5	0	6	5	2	0	3	65	7	0	2	175	4	284	1,089
5:00 PM	0	7	4	10	0	6	11	3	0	2	81	0	0	1	175	1	301	1,023
5:15 PM	0	4	7	7	0	11	12	0	0	5	47	2	0	1	177	2	275	
5:30 PM	0	1	4	10	0	6	2	1	0	3	55	6	0	0	139	2	229	
5:45 PM	0	3	4	4	0	6	7	0	0	2	60	3	0	1	125	3	218	
Count Total	0	30	46	63	0	71	57	16	0	23	518	26	0	19	1,319	20	2,208	
Peak Hour	0	19	27	34	0	38	29	11	0	9	287	12	0	10	710	13	1,199	

Traffic Counts - Heavy Vehicles and Pedestrians/Bicycles in Crosswalk

Interval Start Time	Heavy Vehicles					Total	Interval Start Time	Pedestrians/Bicycles on Crosswalk					Total
	EB	NB	WB	SB				EB	NB	WB	SB		
4:00 PM	0	4	2	7	13	13	4:00 PM	0	0	0	0	0	0
4:15 PM	2	2	1	4	9	9	4:15 PM	0	0	0	0	0	0
4:30 PM	2	1	5	5	13	13	4:30 PM	0	0	0	0	0	0
4:45 PM	1	2	0	2	5	5	4:45 PM	0	0	0	0	0	0
5:00 PM	0	1	0	6	7	7	5:00 PM	0	0	0	0	0	0
5:15 PM	2	0	3	1	6	6	5:15 PM	0	0	0	0	0	0
5:30 PM	0	3	1	2	6	6	5:30 PM	0	0	0	0	0	0
5:45 PM	1	0	0	4	5	5	5:45 PM	0	0	0	0	0	0
Count Total	8	13	12	31	64	64	Count Total	0	0	0	0	0	0
Peak Hour	5	6	6	17	34	34	Peak Hour	0	0	0	0	0	0

Peak Hour

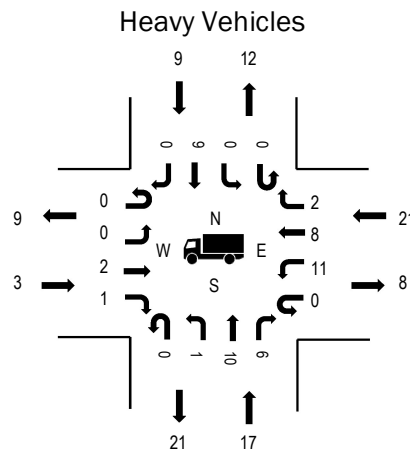
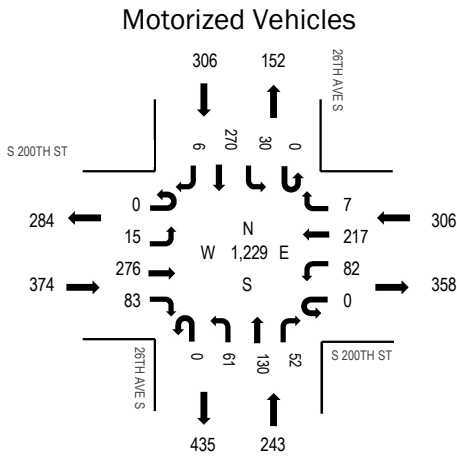

Pedestrians/Bicycles in Crosswalk

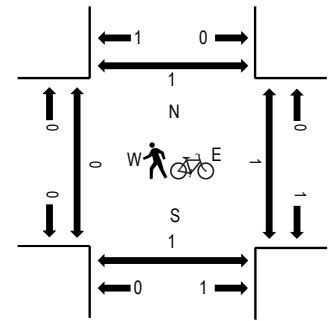

	HV%	PHF
EB	0.8%	0.87
WB	6.9%	0.91
NB	7.0%	0.86
SB	2.9%	0.85
All	4.1%	0.94

Traffic Counts - Motorized Vehicles

Interval Start Time	S 200TH ST Eastbound				S 200TH ST Westbound				26TH AVE S Northbound				26TH AVE S Southbound				Total	Rolling Hour
	U-Turn	Left	Thru	Right	U-Turn	Left	Thru	Right	U-Turn	Left	Thru	Right	U-Turn	Left	Thru	Right		
4:00 PM	0	2	57	18	0	26	45	3	0	4	28	9	0	7	47	0	246	1,161
4:15 PM	0	4	73	16	0	22	50	1	0	19	34	17	0	11	77	2	326	1,229
4:30 PM	0	3	81	23	0	23	54	1	0	8	36	13	0	7	70	0	319	1,187
4:45 PM	0	4	53	15	0	21	59	4	0	15	19	11	0	5	61	3	270	1,107
5:00 PM	0	4	69	29	0	16	54	1	0	19	41	11	0	7	62	1	314	1,072
5:15 PM	0	4	71	23	0	21	39	0	0	9	36	11	0	6	61	3	284	
5:30 PM	0	1	50	18	0	21	45	2	0	10	30	14	0	2	43	3	239	
5:45 PM	0	3	36	18	0	18	53	1	0	13	26	13	0	2	50	2	235	
Count Total	0	25	490	160	0	168	399	13	0	97	250	99	0	47	471	14	2,233	
Peak Hour	0	15	276	83	0	82	217	7	0	61	130	52	0	30	270	6	1,229	

Traffic Counts - Heavy Vehicles and Pedestrians/Bicycles in Crosswalk

Interval Start Time	Heavy Vehicles					Interval Start Time	Pedestrians/Bicycles on Crosswalk				
	EB	NB	WB	SB	Total		EB	NB	WB	SB	Total
4:00 PM	4	4	8	1	17	4:00 PM	0	0	1	1	2
4:15 PM	1	5	6	2	14	4:15 PM	0	0	1	0	1
4:30 PM	0	7	7	4	18	4:30 PM	0	1	0	0	1
4:45 PM	0	3	5	2	10	4:45 PM	0	0	0	1	1
5:00 PM	2	2	3	1	8	5:00 PM	0	0	0	0	0
5:15 PM	1	4	4	1	10	5:15 PM	1	1	0	1	3
5:30 PM	1	4	6	0	11	5:30 PM	0	1	0	0	1
5:45 PM	2	3	3	2	10	5:45 PM	0	1	0	0	1
Count Total	11	32	42	13	98	Count Total	1	4	2	3	10
Peak Hour	3	17	21	9	50	Peak Hour	0	1	1	1	3

Peak Hour

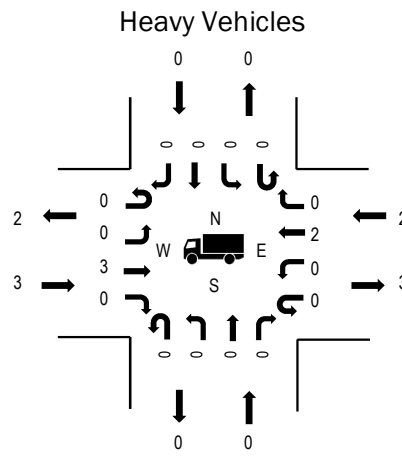
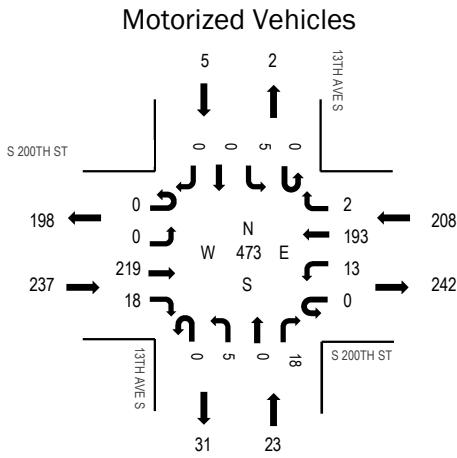

Pedestrians/Bicycles in Crosswalk

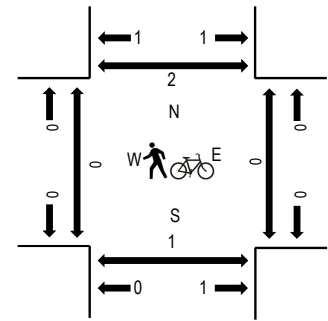

	HV%	PHF
EB	1.3%	0.79
WB	1.0%	0.79
NB	0.0%	0.72
SB	0.0%	0.42
All	1.1%	0.94

Traffic Counts - Motorized Vehicles

Interval Start Time	S 200TH ST Eastbound				S 200TH ST Westbound				13TH AVE S Northbound				13TH AVE S Southbound				Total	Rolling Hour
	U-Turn	Left	Thru	Right	U-Turn	Left	Thru	Right	U-Turn	Left	Thru	Right	U-Turn	Left	Thru	Right		
4:00 PM	0	0	48	6	0	2	31	0	0	2	0	5	0	0	0	0	94	448
4:15 PM	0	0	59	3	0	4	50	0	0	3	0	0	0	0	0	0	119	466
4:30 PM	0	0	63	2	0	1	45	1	0	2	0	6	0	1	0	0	121	473
4:45 PM	0	0	38	3	0	5	61	0	0	0	0	4	0	3	0	0	114	456
5:00 PM	0	0	53	3	0	5	44	1	0	0	0	5	0	1	0	0	112	428
5:15 PM	0	0	65	10	0	2	43	0	0	3	0	3	0	0	0	0	126	
5:30 PM	0	0	45	6	0	5	44	1	0	1	0	2	0	0	0	0	104	
5:45 PM	0	0	31	4	0	7	43	0	0	0	0	1	0	0	0	0	86	
Count Total	0	0	402	37	0	31	361	3	0	11	0	26	0	5	0	0	876	
Peak Hour	0	0	219	18	0	13	193	2	0	5	0	18	0	5	0	0	473	

Traffic Counts - Heavy Vehicles and Pedestrians/Bicycles in Crosswalk

Interval Start Time	Heavy Vehicles					Total	Interval Start Time	Pedestrians/Bicycles on Crosswalk					Total
	EB	NB	WB	SB	EB			NB	WB	SB			
4:00 PM	2	1	1	0	4	4:00 PM	0	0	0	0	0	0	
4:15 PM	0	0	2	0	2	4:15 PM	0	0	0	1	1	1	
4:30 PM	1	0	0	0	1	4:30 PM	0	0	0	0	0	0	
4:45 PM	0	0	1	0	1	4:45 PM	0	0	0	0	0	0	
5:00 PM	1	0	0	0	1	5:00 PM	0	0	0	1	1	1	
5:15 PM	1	0	1	0	2	5:15 PM	0	1	0	1	2	2	
5:30 PM	1	0	1	0	2	5:30 PM	0	0	0	0	0	0	
5:45 PM	1	0	0	0	1	5:45 PM	1	1	0	1	3	3	
Count Total	7	1	6	0	14	Count Total	1	2	0	4	7	7	
Peak Hour	3	0	2	0	5	Peak Hour	0	1	0	2	3	3	

Peak Hour

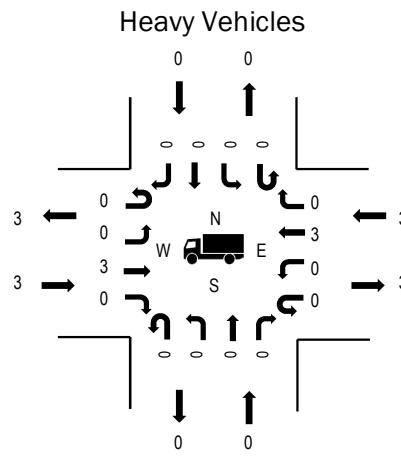
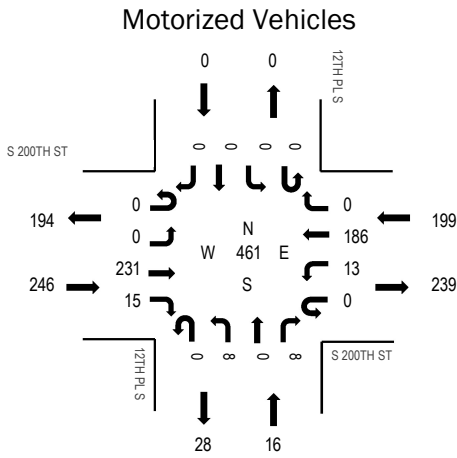

Pedestrians/Bicycles in Crosswalk

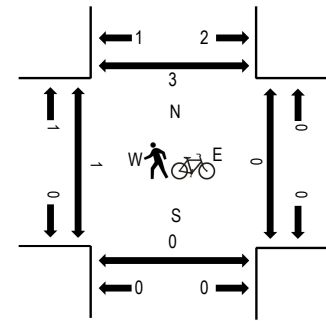

	HV%	PHF
EB	1.2%	0.83
WB	1.5%	0.84
NB	0.0%	0.57
SB	0.0%	0.00
All	1.3%	0.91

Traffic Counts - Motorized Vehicles

Interval Start Time	S 200TH ST Eastbound				S 200TH ST Westbound				12TH PL S Northbound				12TH PL S Southbound				Total	Rolling Hour
	U-Turn	Left	Thru	Right	U-Turn	Left	Thru	Right	U-Turn	Left	Thru	Right	U-Turn	Left	Thru	Right		
4:00 PM	0	0	52	0	0	1	33	0	0	1	0	1	0	0	0	0	88	425
4:15 PM	0	0	60	0	0	3	49	0	0	1	0	2	0	0	0	0	115	449
4:30 PM	0	0	65	4	0	1	47	0	0	1	0	0	0	0	0	0	118	461
4:45 PM	0	0	40	3	0	6	53	0	0	1	0	1	0	0	0	0	104	441
5:00 PM	0	0	56	4	0	4	41	0	0	4	0	3	0	0	0	0	112	420
5:15 PM	0	0	70	4	0	2	45	0	0	2	0	4	0	0	0	0	127	
5:30 PM	0	0	50	1	0	7	39	0	0	0	0	1	0	0	0	0	98	
5:45 PM	0	1	34	2	0	1	42	0	0	2	0	1	0	0	0	0	83	
Count Total	0	1	427	18	0	25	349	0	0	12	0	13	0	0	0	0	845	
Peak Hour	0	0	231	15	0	13	186	0	0	8	0	8	0	0	0	0	461	

Traffic Counts - Heavy Vehicles and Pedestrians/Bicycles in Crosswalk

Interval Start Time	Heavy Vehicles					Total	Interval Start Time	Pedestrians/Bicycles on Crosswalk					Total
	EB	NB	WB	SB				EB	NB	WB	SB		
4:00 PM	2	0	1	0	3	3	4:00 PM	0	0	0	1	1	
4:15 PM	0	0	3	0	3	3	4:15 PM	0	0	0	0	0	
4:30 PM	1	0	0	0	1	1	4:30 PM	0	0	0	0	0	
4:45 PM	0	0	1	0	1	1	4:45 PM	1	0	0	0	1	
5:00 PM	1	0	1	0	2	2	5:00 PM	0	0	0	1	1	
5:15 PM	1	0	1	0	2	2	5:15 PM	0	0	0	2	2	
5:30 PM	1	0	2	0	3	3	5:30 PM	0	0	0	0	0	
5:45 PM	1	0	0	0	1	1	5:45 PM	0	1	0	1	2	
Count Total	7	0	9	0	16	16	Count Total	1	1	0	5	7	
Peak Hour	3	0	3	0	6	6	Peak Hour	1	0	0	3	4	

Appendix B

Level of Service (LOS) Calculations

Level of Service Methodology

Level of service calculations for intersections were based on methodology and procedures outlined in the 2016 update of the *Highway Capacity Manual*, Transportation Research Board (6th Edition) using *Synchro 10* traffic analysis software.

LOS generally refers to the degree of congestion on a roadway or intersection. It is a measure of vehicle operating speed, travel time, travel delays, and driving comfort. A letter scale from A to F generally describes intersection LOS. At signalized intersections, LOS A represents free-flow conditions (motorists experience little or no delays), and LOS F represents forced-flow conditions where motorists experience an average delay in excess of 80 seconds per vehicle.

The LOS reported for signalized intersections represents the average control delay (sec/veh) and can be reported for the overall intersection, for each approach, and for each lane group (additional v/c ratio criteria apply to lane group LOS only).

The LOS reported at stop-controlled intersections is based on the average control delay and can be reported for each controlled minor approach, controlled minor lane group, and controlled major-street movement (and for the overall intersection at all-way stop controlled intersections. Additional v/c ratio criteria apply to lane group or movement LOS only).

Table B1 outlines the current HCM (6th Edition) LOS criteria for signalized and stop-controlled intersections based on these methodologies.

Table B1
LOS Criteria for Signalized and Stop Controlled Intersections¹

SIGNALIZED INTERSECTIONS			STOP-CONTROLLED INTERSECTIONS		
Control Delay (sec/veh)	LOS by Volume-to Capacity (V/C) Ratio ²		Control Delay (sec/veh)	LOS by Volume-to Capacity (V/C) Ratio ³	
	≤ 1.0	> 1.0		≤ 1.0	> 1.0
≤ 10	A	F	≤ 10	A	F
> 10 to ≤ 20	B	F	> 10 to ≤ 15	B	F
> 20 to ≤ 35	C	F	> 15 to ≤ 25	C	F
> 35 to ≤ 55	D	F	> 25 to ≤ 35	D	F
> 55 to ≤ 80	E	F	> 35 to ≤ 50	E	F
> 80	F	F	> 50	F	F

¹ Source: HCM2010 Highway Capacity Manual, Transportation Research Board, 2010.

² For approach-based and intersection-wide assessments at signals, LOS is defined solely by control delay.

³ For two-way stop controlled intersections, the LOS criteria apply to each lane on a given approach and to each approach on the minor street. LOS is not calculated for major-street approaches or for the intersection as a whole at two-way stop controlled intersections. For approach-based and intersection-wide assessments at all-way stop controlled intersections, LOS is solely defined by control delay.

2021 Existing

Lanes, Volumes, Timings
 1: Des Moines Memorial Dr & S 192nd St

02/25/2021



Lane Group	EBL	EBT	EBR	WBL	WBT	WBR	NBL	NBT	NBR	SBL	SBT	SBR
Lane Configurations												
Traffic Volume (vph)	14	30	29	11	30	16	99	1053	77	6	264	11
Future Volume (vph)	14	30	29	11	30	16	99	1053	77	6	264	11
Ideal Flow (vphpl)	1900	1900	1900	1900	1900	1900	1900	1900	1900	1900	1900	1900
Storage Length (ft)	150		0	200		0	150		0	150		0
Storage Lanes	1		0	1		0	1		0	1		0
Taper Length (ft)	25			25			25			25		
Right Turn on Red			Yes			Yes			Yes			Yes
Link Speed (mph)		35			25			35			35	
Link Distance (ft)		1090			1011			616			766	
Travel Time (s)		21.2			27.6			12.0			14.9	
Confl. Peds. (#/hr)			2	2					1			
Peak Hour Factor	0.92	0.92	0.92	0.92	0.92	0.92	0.92	0.92	0.92	0.92	0.92	0.92
Heavy Vehicles (%)	14%	23%	15%	20%	7%	50%	2%	2%	3%	17%	7%	9%
Shared Lane Traffic (%)												
Turn Type	pm+pt	NA		pm+pt	NA		Prot	NA		Prot	NA	
Protected Phases	3	8		7	4		5	2		1	6	
Permitted Phases	8			4								
Detector Phase	3	8		7	4		5	2		1	6	
Switch Phase												
Minimum Initial (s)	5.0	5.0		5.0	5.0		6.0	12.0		10.0	12.0	
Minimum Split (s)	10.0	27.0		10.0	10.0		12.0	22.0		16.0	22.0	
Total Split (s)	20.0	35.0		20.0	35.0		21.0	65.0		36.0	65.0	
Total Split (%)	12.8%	22.4%		12.8%	22.4%		13.5%	41.7%		23.1%	41.7%	
Yellow Time (s)	4.0	4.0		4.0	4.0		4.0	4.0		4.0	4.0	
All-Red Time (s)	1.0	1.0		1.0	1.0		2.0	1.0		2.0	1.0	
Lost Time Adjust (s)	0.0	0.0		0.0	0.0		0.0	0.0		0.0	0.0	
Total Lost Time (s)	5.0	5.0		5.0	5.0		6.0	5.0		6.0	5.0	
Lead/Lag	Lead	Lag		Lead	Lag		Lead	Lag		Lead	Lag	
Lead-Lag Optimize?	Yes	Yes		Yes	Yes		Yes	Yes		Yes	Yes	
Recall Mode	None	None		None	None		None	Min		None	Min	

Intersection Summary

Area Type: Other

Cycle Length: 156

Actuated Cycle Length: 85.8

Natural Cycle: 150

Control Type: Actuated-Uncoordinated

Splits and Phases: 1: Des Moines Memorial Dr & S 192nd St

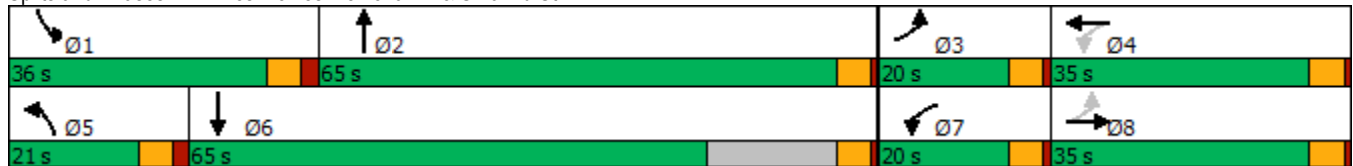

HCM 6th Signalized Intersection Summary

1: Des Moines Memorial Dr & S 192nd St

02/25/2021



Movement	EBL	EBT	EBR	WBL	WBT	WBR	NBL	NBT	NBR	SBL	SBT	SBR
Lane Configurations												
Traffic Volume (veh/h)	14	30	29	11	30	16	99	1053	77	6	264	11
Future Volume (veh/h)	14	30	29	11	30	16	99	1053	77	6	264	11
Initial Q (Qb), veh	0	0	0	0	0	0	0	0	0	0	0	0
Ped-Bike Adj(A_pbT)	0.99		0.98	0.99		0.98	1.00		1.00	1.00		1.00
Parking Bus, Adj	1.00	1.00	1.00	1.00	1.00	1.00	1.00	1.00	1.00	1.00	1.00	1.00
Work Zone On Approach		No			No			No			No	
Adj Sat Flow, veh/h/ln	1693	1559	1678	1604	1796	1159	1870	1870	1856	1648	1796	1767
Adj Flow Rate, veh/h	15	33	32	12	33	17	108	1145	84	7	287	12
Peak Hour Factor	0.92	0.92	0.92	0.92	0.92	0.92	0.92	0.92	0.92	0.92	0.92	0.92
Percent Heavy Veh, %	14	23	15	20	7	50	2	2	3	17	7	9
Cap, veh/h	143	44	42	120	64	33	137	1157	85	28	1049	44
Arrive On Green	0.02	0.06	0.06	0.01	0.06	0.06	0.08	0.67	0.67	0.02	0.61	0.61
Sat Flow, veh/h	1612	721	699	1527	1110	572	1781	1721	126	1570	1712	72
Grp Volume(v), veh/h	15	0	65	12	0	50	108	0	1229	7	0	299
Grp Sat Flow(s),veh/h/ln	1612	0	1419	1527	0	1681	1781	0	1848	1570	0	1783
Q Serve(g_s), s	0.8	0.0	4.0	0.7	0.0	2.6	5.3	0.0	58.2	0.4	0.0	7.0
Cycle Q Clear(g_c), s	0.8	0.0	4.0	0.7	0.0	2.6	5.3	0.0	58.2	0.4	0.0	7.0
Prop In Lane	1.00		0.49	1.00		0.34	1.00		0.07	1.00		0.04
Lane Grp Cap(c), veh/h	143	0	86	120	0	97	137	0	1242	28	0	1093
V/C Ratio(X)	0.10	0.00	0.76	0.10	0.00	0.52	0.79	0.00	0.99	0.25	0.00	0.27
Avail Cap(c_a), veh/h	386	0	477	355	0	565	299	0	1242	527	0	1199
HCM Platoon Ratio	1.00	1.00	1.00	1.00	1.00	1.00	1.00	1.00	1.00	1.00	1.00	1.00
Upstream Filter(l)	1.00	0.00	1.00	1.00	0.00	1.00	1.00	0.00	1.00	1.00	0.00	1.00
Uniform Delay (d), s/veh	38.6	0.0	41.3	38.8	0.0	40.9	40.5	0.0	14.3	43.3	0.0	8.0
Incr Delay (d2), s/veh	0.1	0.0	5.0	0.1	0.0	1.6	3.7	0.0	23.0	9.6	0.0	0.0
Initial Q Delay(d3),s/veh	0.0	0.0	0.0	0.0	0.0	0.0	0.0	0.0	0.0	0.0	0.0	0.0
%ile BackOfQ(50%),veh/ln	0.3	0.0	1.5	0.2	0.0	1.1	2.4	0.0	26.4	0.2	0.0	2.3
Unsig. Movement Delay, s/veh												
LnGrp Delay(d),s/veh	38.7	0.0	46.3	39.0	0.0	42.5	44.2	0.0	37.3	52.9	0.0	8.1
LnGrp LOS	D	A	D	D	A	D	D	A	D	D	A	A
Approach Vol, veh/h		80			62			1337				306
Approach Delay, s/veh		44.9			41.8			37.9				9.1
Approach LOS		D			D			D				A
Timer - Assigned Phs	1	2	3	4	5	6	7	8				
Phs Duration (G+Y+Rc), s	7.6	65.0	6.6	10.1	12.9	59.7	6.3	10.4				
Change Period (Y+Rc), s	6.0	5.0	5.0	5.0	6.0	5.0	5.0	5.0				
Max Green Setting (Gmax), s	30.0	60.0	15.0	30.0	15.0	60.0	15.0	30.0				
Max Q Clear Time (g_c+I1), s	2.4	60.2	2.8	4.6	7.3	9.0	2.7	6.0				
Green Ext Time (p_c), s	0.0	0.0	0.0	0.1	0.1	1.1	0.0	0.2				
Intersection Summary												
HCM 6th Ctrl Delay			33.4									
HCM 6th LOS			C									

Lanes, Volumes, Timings

2: 1st Ave S (SR 509) /1st Ave S (SR 509) & S 199th St

02/25/2021



Lane Group	EBL	EBT	EBR	WBL	WBT	WBR	NBL	NBT	NBR	SBL	SBT	SBR
Lane Configurations		↕	↗		↕		↗	↕		↗	↕↗	
Traffic Volume (vph)	25	20	4	25	51	91	10	335	68	108	183	20
Future Volume (vph)	25	20	4	25	51	91	10	335	68	108	183	20
Ideal Flow (vphpl)	1750	1750	1750	1750	1750	1750	1750	1750	1750	1750	1750	1750
Storage Length (ft)	0		0	0		0	100		0	150		150
Storage Lanes	0		1	0		0	1		0	1		1
Taper Length (ft)	25			25			25			25		
Right Turn on Red			Yes			Yes			Yes			Yes
Link Speed (mph)		25			25			35				35
Link Distance (ft)		134			340			192				566
Travel Time (s)		3.7			9.3			3.7				11.0
Confl. Peds. (#/hr)	3					3	2					2
Peak Hour Factor	0.87	0.87	0.87	0.87	0.87	0.87	0.87	0.87	0.87	0.87	0.87	0.87
Heavy Vehicles (%)	0%	0%	25%	0%	10%	17%	0%	2%	0%	6%	2%	0%
Shared Lane Traffic (%)												
Turn Type	Perm	NA	Perm	Perm	NA		pm+pt	NA		pm+pt	NA	
Protected Phases		4			8		5	2		1		6
Permitted Phases	4		4	8			2			6		
Detector Phase	4	4	4	8	8		5	2		1		6
Switch Phase												
Minimum Initial (s)	7.0	7.0	7.0	7.0	7.0		5.0	10.0		5.0		10.0
Minimum Split (s)	35.9	35.9	35.9	35.9	35.9		10.5	26.9		10.5		26.9
Total Split (s)	35.9	35.9	35.9	35.9	35.9		25.5	55.9		25.5		55.9
Total Split (%)	30.6%	30.6%	30.6%	30.6%	30.6%		21.7%	47.7%		21.7%		47.7%
Yellow Time (s)	3.9	3.9	3.9	3.9	3.9		3.5	3.9		3.5		3.9
All-Red Time (s)	2.0	2.0	2.0	2.0	2.0		2.0	2.0		2.0		2.0
Lost Time Adjust (s)		0.0	0.0		0.0		0.0	0.0		0.0		0.0
Total Lost Time (s)		5.9	5.9		5.9		5.5	5.9		5.5		5.9
Lead/Lag							Lead	Lag		Lead		Lag
Lead-Lag Optimize?							Yes	Yes		Yes		Yes
Recall Mode	None	None	None	None	None		None	Min		None		Min

Intersection Summary

Area Type: Other

Cycle Length: 117.3

Actuated Cycle Length: 68

Natural Cycle: 75

Control Type: Actuated-Uncoordinated

Splits and Phases: 2: 1st Ave S (SR 509) /1st Ave S (SR 509) & S 199th St



HCM 6th Signalized Intersection Summary
 2: 1st Ave S (SR 509) /1st Ave S (SR 509) & S 199th St

02/25/2021



Movement	EBL	EBT	EBR	WBL	WBT	WBR	NBL	NBT	NBR	SBL	SBT	SBR
Lane Configurations		↕	↗		↕		↗	↕		↗	↕↗	
Traffic Volume (veh/h)	25	20	4	25	51	91	10	335	68	108	183	20
Future Volume (veh/h)	25	20	4	25	51	91	10	335	68	108	183	20
Initial Q (Qb), veh	0	0	0	0	0	0	0	0	0	0	0	0
Ped-Bike Adj(A_pbT)	1.00		1.00	1.00		0.99	1.00		1.00	1.00		1.00
Parking Bus, Adj	1.00	1.00	1.00	1.00	1.00	1.00	1.00	1.00	1.00	1.00	1.00	1.00
Work Zone On Approach		No			No			No			No	
Adj Sat Flow, veh/h/ln	1750	1750	1409	1750	1614	1518	1750	1723	1750	1668	1723	1750
Adj Flow Rate, veh/h	29	23	5	29	59	105	11	385	78	124	210	23
Peak Hour Factor	0.87	0.87	0.87	0.87	0.87	0.87	0.87	0.87	0.87	0.87	0.87	0.87
Percent Heavy Veh, %	0	0	25	0	10	17	0	2	0	6	2	0
Cap, veh/h	244	162	245	103	109	160	577	543	110	390	1356	147
Arrive On Green	0.21	0.21	0.21	0.21	0.21	0.21	0.01	0.39	0.39	0.08	0.46	0.46
Sat Flow, veh/h	674	785	1189	121	528	775	1667	1390	282	1589	2978	323
Grp Volume(v), veh/h	52	0	5	193	0	0	11	0	463	124	114	119
Grp Sat Flow(s),veh/h/ln	1459	0	1189	1424	0	0	1667	0	1671	1589	1637	1664
Q Serve(g_s), s	0.0	0.0	0.2	1.9	0.0	0.0	0.2	0.0	12.5	2.4	2.2	2.2
Cycle Q Clear(g_c), s	1.3	0.0	0.2	6.5	0.0	0.0	0.2	0.0	12.5	2.4	2.2	2.2
Prop In Lane	0.56		1.00	0.15		0.54	1.00		0.17	1.00		0.19
Lane Grp Cap(c), veh/h	406	0	245	371	0	0	577	0	653	390	745	758
V/C Ratio(X)	0.13	0.00	0.02	0.52	0.00	0.00	0.02	0.00	0.71	0.32	0.15	0.16
Avail Cap(c_a), veh/h	886	0	669	868	0	0	1179	0	1567	861	1534	1560
HCM Platoon Ratio	1.00	1.00	1.00	1.00	1.00	1.00	1.00	1.00	1.00	1.00	1.00	1.00
Upstream Filter(l)	1.00	0.00	1.00	1.00	0.00	0.00	1.00	0.00	1.00	1.00	1.00	1.00
Uniform Delay (d), s/veh	17.3	0.0	16.9	19.4	0.0	0.0	9.5	0.0	13.7	9.8	8.5	8.5
Incr Delay (d2), s/veh	0.2	0.0	0.1	1.9	0.0	0.0	0.0	0.0	3.0	0.5	0.2	0.2
Initial Q Delay(d3),s/veh	0.0	0.0	0.0	0.0	0.0	0.0	0.0	0.0	0.0	0.0	0.0	0.0
%ile BackOfQ(50%),veh/ln	0.5	0.0	0.0	2.2	0.0	0.0	0.1	0.0	4.3	0.7	0.7	0.7
Unsig. Movement Delay, s/veh												
LnGrp Delay(d),s/veh	17.6	0.0	16.9	21.3	0.0	0.0	9.5	0.0	16.7	10.3	8.7	8.7
LnGrp LOS	B	A	B	C	A	A	A	A	B	B	A	A
Approach Vol, veh/h		57			193			474			357	
Approach Delay, s/veh		17.5			21.3			16.6			9.3	
Approach LOS		B			C			B			A	
Timer - Assigned Phs	1	2		4	5	6		8				
Phs Duration (G+Y+Rc), s	9.7	26.7		16.9	6.3	30.2		16.9				
Change Period (Y+Rc), s	5.5	5.9		5.9	5.5	5.9		5.9				
Max Green Setting (Gmax), s	20.0	50.0		30.0	20.0	50.0		30.0				
Max Q Clear Time (g_c+I1), s	4.4	14.5		3.3	2.2	4.2		8.5				
Green Ext Time (p_c), s	0.3	6.4		0.4	0.0	2.8		1.8				
Intersection Summary												
HCM 6th Ctrl Delay			15.1									
HCM 6th LOS			B									

Lanes, Volumes, Timings
 3: Des Moines Memorial Dr & S 200th St

02/25/2021



Lane Group	EBL	EBT	EBR	WBL	WBT	WBR	NBL	NBT	NBR	SBL	SBT	SBR
Lane Configurations												
Traffic Volume (vph)	27	137	31	17	127	84	34	919	56	19	254	6
Future Volume (vph)	27	137	31	17	127	84	34	919	56	19	254	6
Ideal Flow (vphpl)	1900	1900	1900	1900	1900	1900	1900	1900	1900	1900	1900	1900
Storage Length (ft)	0		200	200		350	200		0	200		0
Storage Lanes	1		1	1		1	1		0	1		0
Taper Length (ft)	25			25			25			25		
Right Turn on Red			Yes			Yes			Yes			Yes
Link Speed (mph)		25			35			35			35	
Link Distance (ft)		533			538			421			545	
Travel Time (s)		14.5			10.5			8.2			10.6	
Confl. Peds. (#/hr)	8		1	1		8	3					3
Peak Hour Factor	0.95	0.95	0.95	0.95	0.95	0.95	0.95	0.95	0.95	0.95	0.95	0.95
Heavy Vehicles (%)	3%	3%	3%	3%	3%	3%	1%	1%	1%	1%	1%	1%
Shared Lane Traffic (%)												
Turn Type	pm+pt	NA		pm+pt	NA	Perm	pm+pt	NA		pm+pt	NA	
Protected Phases	3	8		7	4		5	2		1	6	
Permitted Phases	8			4		4	2			6		
Detector Phase	3	8		7	4	4	5	2		1	6	
Switch Phase												
Minimum Initial (s)	5.0	5.0		5.0	5.0	5.0	5.0	5.0		5.0	5.0	
Minimum Split (s)	10.0	30.0		10.0	31.0	31.0	10.0	32.0		10.0	30.0	
Total Split (s)	25.0	40.0		25.0	40.0	40.0	25.0	55.0		25.0	55.0	
Total Split (%)	17.2%	27.6%		17.2%	27.6%	27.6%	17.2%	37.9%		17.2%	37.9%	
Yellow Time (s)	4.0	4.0		4.0	4.0	4.0	4.0	4.0		4.0	4.0	
All-Red Time (s)	1.0	1.0		1.0	1.0	1.0	1.0	1.0		1.0	1.0	
Lost Time Adjust (s)	0.0	0.0		0.0	0.0	0.0	0.0	0.0		0.0	0.0	
Total Lost Time (s)	5.0	5.0		5.0	5.0	5.0	5.0	5.0		5.0	5.0	
Lead/Lag	Lead	Lag		Lead	Lag	Lag	Lead	Lag		Lead	Lag	
Lead-Lag Optimize?	Yes	Yes		Yes	Yes	Yes	Yes	Yes		Yes	Yes	
Recall Mode	None	None		None	None	None	None	None		None	None	

Intersection Summary

Area Type: Other

Cycle Length: 145

Actuated Cycle Length: 88.2

Natural Cycle: 115

Control Type: Actuated-Uncoordinated

Splits and Phases: 3: Des Moines Memorial Dr & S 200th St

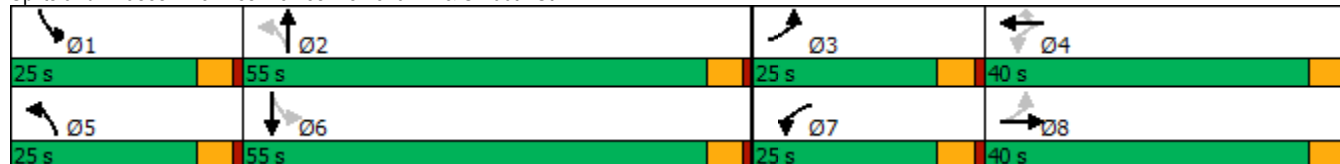

HCM 6th Signalized Intersection Summary
 3: Des Moines Memorial Dr & S 200th St

02/25/2021



Movement	EBL	EBT	EBR	WBL	WBT	WBR	NBL	NBT	NBR	SBL	SBT	SBR
Lane Configurations												
Traffic Volume (veh/h)	27	137	31	17	127	84	34	919	56	19	254	6
Future Volume (veh/h)	27	137	31	17	127	84	34	919	56	19	254	6
Initial Q (Qb), veh	0	0	0	0	0	0	0	0	0	0	0	0
Ped-Bike Adj(A_pbT)	0.98		0.97	0.98		0.97	1.00		1.00	1.00		1.00
Parking Bus, Adj	1.00	1.00	1.00	1.00	1.00	1.00	1.00	1.00	1.00	1.00	1.00	1.00
Work Zone On Approach		No			No			No			No	
Adj Sat Flow, veh/h/ln	1856	1856	1856	1856	1856	1856	1885	1885	1885	1885	1885	1885
Adj Flow Rate, veh/h	28	144	33	18	134	88	36	967	59	20	267	6
Peak Hour Factor	0.95	0.95	0.95	0.95	0.95	0.95	0.95	0.95	0.95	0.95	0.95	0.95
Percent Heavy Veh, %	3	3	3	3	3	3	1	1	1	1	1	1
Cap, veh/h	220	220	50	188	266	219	688	1010	62	153	1034	23
Arrive On Green	0.03	0.15	0.15	0.02	0.14	0.14	0.03	0.57	0.57	0.02	0.56	0.56
Sat Flow, veh/h	1767	1452	333	1767	1856	1529	1795	1758	107	1795	1836	41
Grp Volume(v), veh/h	28	0	177	18	134	88	36	0	1026	20	0	273
Grp Sat Flow(s),veh/h/ln	1767	0	1785	1767	1856	1529	1795	0	1866	1795	0	1878
Q Serve(g_s), s	1.1	0.0	8.0	0.7	5.7	4.5	0.7	0.0	44.8	0.4	0.0	6.4
Cycle Q Clear(g_c), s	1.1	0.0	8.0	0.7	5.7	4.5	0.7	0.0	44.8	0.4	0.0	6.4
Prop In Lane	1.00		0.19	1.00		1.00	1.00		0.06	1.00		0.02
Lane Grp Cap(c), veh/h	220	0	270	188	266	219	688	0	1071	153	0	1057
V/C Ratio(X)	0.13	0.00	0.66	0.10	0.50	0.40	0.05	0.00	0.96	0.13	0.00	0.26
Avail Cap(c_a), veh/h	580	0	725	562	754	621	1044	0	1083	530	0	1090
HCM Platoon Ratio	1.00	1.00	1.00	1.00	1.00	1.00	1.00	1.00	1.00	1.00	1.00	1.00
Upstream Filter(l)	1.00	0.00	1.00	1.00	1.00	1.00	1.00	0.00	1.00	1.00	0.00	1.00
Uniform Delay (d), s/veh	30.2	0.0	34.5	30.8	34.1	33.6	7.4	0.0	17.4	19.1	0.0	9.6
Incr Delay (d2), s/veh	0.3	0.0	5.7	0.2	3.1	2.5	0.0	0.0	18.3	0.4	0.0	0.3
Initial Q Delay(d3),s/veh	0.0	0.0	0.0	0.0	0.0	0.0	0.0	0.0	0.0	0.0	0.0	0.0
%ile BackOfQ(50%),veh/ln	0.5	0.0	3.9	0.3	2.7	1.8	0.2	0.0	21.6	0.2	0.0	2.4
Unsig. Movement Delay, s/veh												
LnGrp Delay(d),s/veh	30.5	0.0	40.1	31.0	37.2	36.1	7.4	0.0	35.7	19.5	0.0	9.9
LnGrp LOS	C	A	D	C	D	D	A	A	D	B	A	A
Approach Vol, veh/h		205			240			1062			293	
Approach Delay, s/veh		38.8			36.3			34.7			10.6	
Approach LOS		D			D			C			B	
Timer - Assigned Phs	1	2	3	4	5	6	7	8				
Phs Duration (G+Y+Rc), s	6.9	54.5	7.4	17.3	7.9	53.5	6.7	18.0				
Change Period (Y+Rc), s	5.0	5.0	5.0	5.0	5.0	5.0	5.0	5.0				
Max Green Setting (Gmax), s	20.0	50.0	20.0	35.0	20.0	50.0	20.0	35.0				
Max Q Clear Time (g_c+I1), s	2.4	46.8	3.1	7.7	2.7	8.4	2.7	10.0				
Green Ext Time (p_c), s	0.0	2.6	0.0	2.1	0.0	3.4	0.0	1.9				
Intersection Summary												
HCM 6th Ctrl Delay			31.5									
HCM 6th LOS			C									

Lanes, Volumes, Timings
4: 26th Ave S & S 200th St

02/25/2021

Lane Group	EBL	EBT	EBR	WBL	WBT	WBR	NBL	NBT	NBR	SBL	SBT	SBR
Lane Configurations												
Traffic Volume (vph)	31	213	32	49	335	7	75	147	38	5	65	8
Future Volume (vph)	31	213	32	49	335	7	75	147	38	5	65	8
Ideal Flow (vphpl)	1900	1900	1900	1900	1900	1900	1900	1900	1900	1900	1900	1900
Grade (%)		9%			-9%			6%			-7%	
Storage Length (ft)	150		150	175		0	100		0	100		0
Storage Lanes	1		1	1		1	1		0	1		0
Taper Length (ft)	25			25			25			25		
Right Turn on Red			Yes			Yes			Yes			Yes
Link Speed (mph)		35			35			35			35	
Link Distance (ft)		707			875			1004			1058	
Travel Time (s)		13.8			17.0			19.6			20.6	
Confl. Peds. (#/hr)	1					1						
Peak Hour Factor	0.96	0.96	0.96	0.96	0.96	0.96	0.96	0.96	0.96	0.96	0.96	0.96
Heavy Vehicles (%)	18%	11%	11%	25%	9%	29%	5%	8%	34%	0%	5%	0%
Shared Lane Traffic (%)												
Turn Type	pm+pt	NA		pm+pt	NA	Perm	Perm	NA		Perm	NA	
Protected Phases	3	8		7	4			6			2	
Permitted Phases	8			4		4	6			2		
Detector Phase	3	8		7	4	4	6	6		2	2	
Switch Phase												
Minimum Initial (s)	5.0	10.0		5.0	10.0	10.0	10.0	10.0		10.0	10.0	
Minimum Split (s)	10.0	36.0		10.0	40.0	40.0	35.0	35.0		30.0	30.0	
Total Split (s)	30.0	55.0		30.0	55.0	55.0	55.0	55.0		55.0	55.0	
Total Split (%)	21.4%	39.3%		21.4%	39.3%	39.3%	39.3%	39.3%		39.3%	39.3%	
Yellow Time (s)	4.0	4.0		4.0	4.0	4.0	4.0	4.0		4.0	4.0	
All-Red Time (s)	1.0	1.0		1.0	1.0	1.0	1.0	1.0		1.0	1.0	
Lost Time Adjust (s)	0.0	0.0		0.0	0.0	0.0	0.0	0.0		0.0	0.0	
Total Lost Time (s)	5.0	5.0		5.0	5.0	5.0	5.0	5.0		5.0	5.0	
Lead/Lag	Lead	Lag		Lead	Lag	Lag						
Lead-Lag Optimize?	Yes	Yes		Yes	Yes	Yes						
Recall Mode	None	Min		None	Min	Min	None	None		None	None	

Intersection Summary

Area Type: Other

Cycle Length: 140

Actuated Cycle Length: 41.5

Natural Cycle: 85

Control Type: Actuated-Uncoordinated

Splits and Phases: 4: 26th Ave S & S 200th St

Ø2	Ø3	Ø4
55 s	30 s	55 s
Ø6	Ø7	Ø8
55 s	30 s	55 s

HCM 6th Signalized Intersection Summary

4: 26th Ave S & S 200th St

02/25/2021



Movement	EBL	EBT	EBR	WBL	WBT	WBR	NBL	NBT	NBR	SBL	SBT	SBR
Lane Configurations												
Traffic Volume (veh/h)	31	213	32	49	335	7	75	147	38	5	65	8
Future Volume (veh/h)	31	213	32	49	335	7	75	147	38	5	65	8
Initial Q (Qb), veh	0	0	0	0	0	0	0	0	0	0	0	0
Ped-Bike Adj(A_pbT)	1.00		1.00	1.00		1.00	1.00		1.00	1.00		1.00
Parking Bus, Adj	1.00		1.00	1.00		1.00	1.00		1.00	1.00		1.00
Work Zone On Approach		No			No			No			No	
Adj Sat Flow, veh/h/ln	1156	1260	1260	1879	2119	1819	1614	1569	1184	2175	2100	2175
Adj Flow Rate, veh/h	32	222	33	51	349	7	78	153	40	5	68	8
Peak Hour Factor	0.96	0.96	0.96	0.96	0.96	0.96	0.96	0.96	0.96	0.96	0.96	0.96
Percent Heavy Veh, %	18	11	11	25	9	29	5	8	34	0	5	0
Cap, veh/h	334	579	85	507	622	452	479	619	157	486	948	110
Arrive On Green	0.04	0.28	0.28	0.06	0.29	0.29	0.26	0.26	0.26	0.26	0.26	0.26
Sat Flow, veh/h	1101	2094	307	1789	2119	1540	1142	2354	598	1384	3604	417
Grp Volume(v), veh/h	32	126	129	51	349	7	78	95	98	5	37	39
Grp Sat Flow(s),veh/h/ln	1101	1197	1204	1789	2119	1540	1142	1491	1462	1384	1995	2025
Q Serve(g_s), s	0.8	3.1	3.2	0.7	5.2	0.1	2.0	1.9	2.0	0.1	0.5	0.5
Cycle Q Clear(g_c), s	0.8	3.1	3.2	0.7	5.2	0.1	2.6	1.9	2.0	2.1	0.5	0.5
Prop In Lane	1.00		0.25	1.00		1.00	1.00		0.41	1.00		0.21
Lane Grp Cap(c), veh/h	334	331	333	507	622	452	479	392	385	486	525	533
V/C Ratio(X)	0.10	0.38	0.39	0.10	0.56	0.02	0.16	0.24	0.25	0.01	0.07	0.07
Avail Cap(c_a), veh/h	1037	1618	1628	1617	2864	2081	1722	2015	1976	1992	2697	2738
HCM Platoon Ratio	1.00	1.00	1.00	1.00	1.00	1.00	1.00	1.00	1.00	1.00	1.00	1.00
Upstream Filter(l)	1.00	1.00	1.00	1.00	1.00	1.00	1.00	1.00	1.00	1.00	1.00	1.00
Uniform Delay (d), s/veh	9.3	10.8	10.9	8.7	11.1	9.3	11.2	10.7	10.8	11.6	10.2	10.2
Incr Delay (d2), s/veh	0.0	0.3	0.3	0.0	0.3	0.0	0.1	0.1	0.1	0.0	0.0	0.0
Initial Q Delay(d3),s/veh	0.0	0.0	0.0	0.0	0.0	0.0	0.0	0.0	0.0	0.0	0.0	0.0
%ile BackOfQ(50%),veh/ln	0.1	0.6	0.7	0.2	1.8	0.0	0.4	0.5	0.5	0.0	0.2	0.2
Unsig. Movement Delay, s/veh												
LnGrp Delay(d),s/veh	9.3	11.1	11.1	8.7	11.3	9.3	11.3	10.8	10.9	11.6	10.3	10.3
LnGrp LOS	A	B	B	A	B	A	B	B	B	B	B	B
Approach Vol, veh/h		287			407			271				81
Approach Delay, s/veh		10.9			11.0			11.0				10.3
Approach LOS		B			B			B				B
Timer - Assigned Phs		2	3	4		6	7	8				
Phs Duration (G+Y+Rc), s		14.7	6.4	15.9		14.7	7.0	15.2				
Change Period (Y+Rc), s		5.0	5.0	5.0		5.0	5.0	5.0				
Max Green Setting (Gmax), s		50.0	25.0	50.0		50.0	25.0	50.0				
Max Q Clear Time (g_c+I1), s		4.1	2.8	7.2		4.6	2.7	5.2				
Green Ext Time (p_c), s		0.1	0.0	0.3		0.2	0.0	0.2				
Intersection Summary												
HCM 6th Ctrl Delay			10.9									
HCM 6th LOS			B									

Lanes, Volumes, Timings
1: Des Moines Memorial Dr & S 192nd St

02/25/2021



Lane Group	EBL	EBT	EBR	WBL	WBT	WBR	NBL	NBT	NBR	SBL	SBT	SBR
Lane Configurations												
Traffic Volume (vph)	9	29	34	56	30	15	21	465	44	11	594	9
Future Volume (vph)	9	29	34	56	30	15	21	465	44	11	594	9
Ideal Flow (vphpl)	1900	1900	1900	1900	1900	1900	1900	1900	1900	1900	1900	1900
Storage Length (ft)	150		0	200		0	150		0	150		0
Storage Lanes	1		0	1		0	1		0	1		0
Taper Length (ft)	25			25			25			25		
Right Turn on Red			Yes			Yes			Yes			Yes
Link Speed (mph)		35			25			35			35	
Link Distance (ft)		1090			1011			616			766	
Travel Time (s)		21.2			27.6			12.0			14.9	
Confl. Peds. (#/hr)			2	2					1			
Peak Hour Factor	0.84	0.84	0.84	0.84	0.84	0.84	0.84	0.84	0.84	0.84	0.84	0.84
Heavy Vehicles (%)	22%	3%	12%	7%	23%	13%	8%	6%	16%	46%	2%	22%
Shared Lane Traffic (%)												
Turn Type	pm+pt	NA		pm+pt	NA		Prot	NA		Prot	NA	
Protected Phases	3	8		7	4		5	2		1	6	
Permitted Phases	8			4								
Detector Phase	3	8		7	4		5	2		1	6	
Switch Phase												
Minimum Initial (s)	5.0	5.0		5.0	5.0		6.0	12.0		10.0	12.0	
Minimum Split (s)	10.0	27.0		10.0	10.0		12.0	22.0		16.0	22.0	
Total Split (s)	20.0	35.0		20.0	35.0		21.0	65.0		36.0	65.0	
Total Split (%)	12.8%	22.4%		12.8%	22.4%		13.5%	41.7%		23.1%	41.7%	
Yellow Time (s)	4.0	4.0		4.0	4.0		4.0	4.0		4.0	4.0	
All-Red Time (s)	1.0	1.0		1.0	1.0		2.0	1.0		2.0	1.0	
Lost Time Adjust (s)	0.0	0.0		0.0	0.0		0.0	0.0		0.0	0.0	
Total Lost Time (s)	5.0	5.0		5.0	5.0		6.0	5.0		6.0	5.0	
Lead/Lag	Lead	Lag		Lead	Lag		Lead	Lag		Lead	Lag	
Lead-Lag Optimize?	Yes	Yes		Yes	Yes		Yes	Yes		Yes	Yes	
Recall Mode	None	None		None	None		None	Min		None	Min	

Intersection Summary

Area Type: Other

Cycle Length: 156

Actuated Cycle Length: 72.1

Natural Cycle: 90

Control Type: Actuated-Uncoordinated

Splits and Phases: 1: Des Moines Memorial Dr & S 192nd St

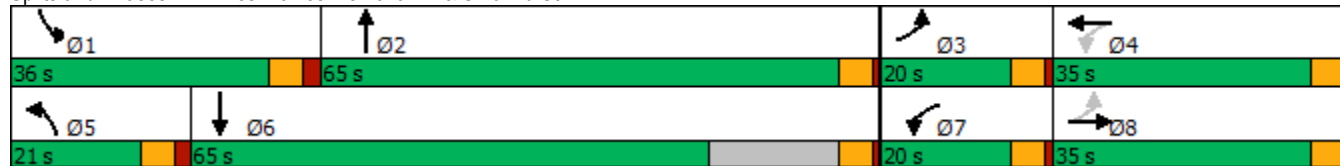

HCM 6th Signalized Intersection Summary

1: Des Moines Memorial Dr & S 192nd St

02/25/2021



Movement	EBL	EBT	EBR	WBL	WBT	WBR	NBL	NBT	NBR	SBL	SBT	SBR
Lane Configurations												
Traffic Volume (veh/h)	9	29	34	56	30	15	21	465	44	11	594	9
Future Volume (veh/h)	9	29	34	56	30	15	21	465	44	11	594	9
Initial Q (Qb), veh	0	0	0	0	0	0	0	0	0	0	0	0
Ped-Bike Adj(A_pbT)	0.99		0.99	0.99		0.99	1.00		1.00	1.00		1.00
Parking Bus, Adj	1.00	1.00	1.00	1.00	1.00	1.00	1.00	1.00	1.00	1.00	1.00	1.00
Work Zone On Approach		No			No			No			No	
Adj Sat Flow, veh/h/ln	1574	1856	1722	1796	1559	1707	1781	1811	1663	1218	1870	1574
Adj Flow Rate, veh/h	11	35	40	67	36	18	25	554	52	13	707	11
Peak Hour Factor	0.84	0.84	0.84	0.84	0.84	0.84	0.84	0.84	0.84	0.84	0.84	0.84
Percent Heavy Veh, %	22	3	12	7	23	13	8	6	16	46	2	22
Cap, veh/h	232	53	61	266	110	55	59	731	69	38	820	13
Arrive On Green	0.01	0.07	0.07	0.06	0.11	0.11	0.03	0.45	0.45	0.03	0.45	0.45
Sat Flow, veh/h	1499	785	897	1711	977	489	1697	1630	153	1160	1837	29
Grp Volume(v), veh/h	11	0	75	67	0	54	25	0	606	13	0	718
Grp Sat Flow(s),veh/h/ln	1499	0	1683	1711	0	1466	1697	0	1783	1160	0	1865
Q Serve(g_s), s	0.4	0.0	2.3	1.9	0.0	1.8	0.8	0.0	15.2	0.6	0.0	18.6
Cycle Q Clear(g_c), s	0.4	0.0	2.3	1.9	0.0	1.8	0.8	0.0	15.2	0.6	0.0	18.6
Prop In Lane	1.00		0.53	1.00		0.33	1.00		0.09	1.00		0.02
Lane Grp Cap(c), veh/h	232	0	114	266	0	165	59	0	800	38	0	833
V/C Ratio(X)	0.05	0.00	0.66	0.25	0.00	0.33	0.42	0.00	0.76	0.34	0.00	0.86
Avail Cap(c_a), veh/h	630	0	942	644	0	820	475	0	1996	649	0	2088
HCM Platoon Ratio	1.00	1.00	1.00	1.00	1.00	1.00	1.00	1.00	1.00	1.00	1.00	1.00
Upstream Filter(l)	1.00	0.00	1.00	1.00	0.00	1.00	1.00	0.00	1.00	1.00	0.00	1.00
Uniform Delay (d), s/veh	22.8	0.0	24.4	21.3	0.0	21.9	25.3	0.0	12.3	25.4	0.0	13.3
Incr Delay (d2), s/veh	0.0	0.0	2.4	0.2	0.0	0.4	1.8	0.0	0.6	10.9	0.0	1.1
Initial Q Delay(d3),s/veh	0.0	0.0	0.0	0.0	0.0	0.0	0.0	0.0	0.0	0.0	0.0	0.0
%ile BackOfQ(50%),veh/ln	0.1	0.0	0.9	0.7	0.0	0.6	0.3	0.0	4.8	0.3	0.0	6.2
Unsig. Movement Delay, s/veh												
LnGrp Delay(d),s/veh	22.8	0.0	26.7	21.5	0.0	22.3	27.1	0.0	12.9	36.3	0.0	14.4
LnGrp LOS	C	A	C	C	A	C	C	A	B	D	A	B
Approach Vol, veh/h		86			121			631				731
Approach Delay, s/veh		26.2			21.9			13.5				14.8
Approach LOS		C			C			B				B
Timer - Assigned Phs	1	2	3	4	5	6	7	8				
Phs Duration (G+Y+Rc), s	7.8	29.0	5.8	11.0	7.9	28.9	8.2	8.6				
Change Period (Y+Rc), s	6.0	5.0	5.0	5.0	6.0	5.0	5.0	5.0				
Max Green Setting (Gmax), s	30.0	60.0	15.0	30.0	15.0	60.0	15.0	30.0				
Max Q Clear Time (g_c+I1), s	2.6	17.2	2.4	3.8	2.8	20.6	3.9	4.3				
Green Ext Time (p_c), s	0.0	2.7	0.0	0.2	0.0	3.4	0.0	0.2				
Intersection Summary												
HCM 6th Ctrl Delay			15.4									
HCM 6th LOS			B									

Lanes, Volumes, Timings
2: 1st Ave S (SR 509) & S 199th St

02/25/2021



Lane Group	EBL	EBT	EBR	WBL	WBT	WBR	NBL	NBT	NBR	SBL	SBT	SBR
Lane Configurations		↕	↗		↕		↗	↖		↖	↕	↕
Traffic Volume (vph)	29	64	15	80	48	67	6	325	36	92	390	30
Future Volume (vph)	29	64	15	80	48	67	6	325	36	92	390	30
Ideal Flow (vphpl)	1750	1750	1750	1750	1750	1750	1750	1750	1750	1750	1750	1750
Storage Length (ft)	0		0	0		0	100		0	150		150
Storage Lanes	0		1	0		0	1		0	1		1
Taper Length (ft)	25			25			25			25		
Right Turn on Red			Yes			Yes			Yes			Yes
Link Speed (mph)		25			25			35			35	
Link Distance (ft)		134			340			192			566	
Travel Time (s)		3.7			9.3			3.7			11.0	
Confl. Peds. (#/hr)	1		1	1		1	7		1	1		7
Peak Hour Factor	0.89	0.89	0.89	0.89	0.89	0.89	0.89	0.89	0.89	0.89	0.89	0.89
Heavy Vehicles (%)	0%	0%	0%	7%	0%	0%	0%	2%	0%	0%	2%	0%
Shared Lane Traffic (%)												
Turn Type	Perm	NA	Perm	Perm	NA		pm+pt	NA		pm+pt	NA	
Protected Phases		4			8		5	2		1		6
Permitted Phases	4		4	8			2			6		
Detector Phase	4	4	4	8	8		5	2		1		6
Switch Phase												
Minimum Initial (s)	7.0	7.0	7.0	7.0	7.0		5.0	10.0		5.0		10.0
Minimum Split (s)	35.9	35.9	35.9	35.9	35.9		10.5	26.9		10.5		26.9
Total Split (s)	30.9	30.9	30.9	30.9	30.9		25.5	45.9		25.5		45.9
Total Split (%)	30.2%	30.2%	30.2%	30.2%	30.2%		24.9%	44.9%		24.9%		44.9%
Yellow Time (s)	3.9	3.9	3.9	3.9	3.9		3.5	3.9		3.5		3.9
All-Red Time (s)	2.0	2.0	2.0	2.0	2.0		2.0	2.0		2.0		2.0
Lost Time Adjust (s)		0.0	0.0		0.0		0.0	0.0		0.0		0.0
Total Lost Time (s)		5.9	5.9		5.9		5.5	5.9		5.5		5.9
Lead/Lag							Lead	Lag		Lead		Lag
Lead-Lag Optimize?							Yes	Yes		Yes		Yes
Recall Mode	None	None	None	None	None		None	Min		None		Min

Intersection Summary

Area Type: Other

Cycle Length: 102.3

Actuated Cycle Length: 64.9

Natural Cycle: 75

Control Type: Actuated-Uncoordinated

Splits and Phases: 2: 1st Ave S (SR 509) & S 199th St

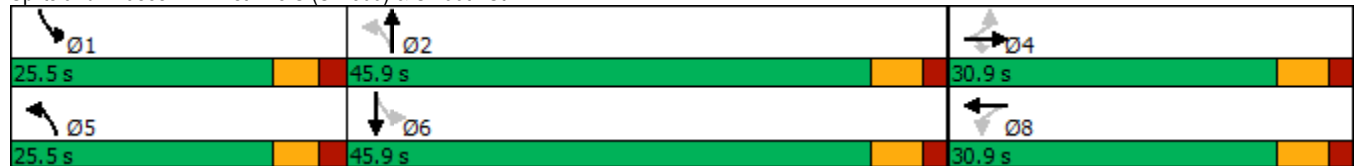

HCM 6th Signalized Intersection Summary
 2: 1st Ave S (SR 509) & S 199th St

02/25/2021

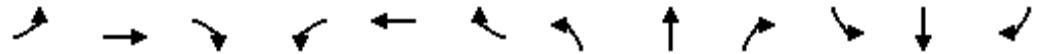

Movement	EBL	EBT	EBR	WBL	WBT	WBR	NBL	NBT	NBR	SBL	SBT	SBR
Lane Configurations		↕	↗		↕		↗	↕		↗	↕↗	
Traffic Volume (veh/h)	29	64	15	80	48	67	6	325	36	92	390	30
Future Volume (veh/h)	29	64	15	80	48	67	6	325	36	92	390	30
Initial Q (Qb), veh	0	0	0	0	0	0	0	0	0	0	0	0
Ped-Bike Adj(A_pbT)	1.00		1.00	1.00		1.00	1.00		0.99	1.00		0.99
Parking Bus, Adj	1.00	1.00	1.00	1.00	1.00	1.00	1.00	1.00	1.00	1.00	1.00	1.00
Work Zone On Approach		No			No			No			No	
Adj Sat Flow, veh/h/ln	1750	1750	1750	1654	1750	1750	1750	1723	1750	1750	1723	1750
Adj Flow Rate, veh/h	33	72	17	90	54	75	7	365	40	103	438	34
Peak Hour Factor	0.89	0.89	0.89	0.89	0.89	0.89	0.89	0.89	0.89	0.89	0.89	0.89
Percent Heavy Veh, %	0	0	0	7	0	0	0	2	0	0	2	0
Cap, veh/h	169	295	329	203	106	107	437	534	58	407	1285	99
Arrive On Green	0.22	0.22	0.22	0.22	0.22	0.22	0.01	0.35	0.35	0.08	0.42	0.42
Sat Flow, veh/h	330	1329	1481	450	478	484	1667	1524	167	1667	3076	238
Grp Volume(v), veh/h	105	0	17	219	0	0	7	0	405	103	232	240
Grp Sat Flow(s),veh/h/ln	1659	0	1481	1413	0	0	1667	0	1691	1667	1637	1678
Q Serve(g_s), s	0.0	0.0	0.4	4.6	0.0	0.0	0.1	0.0	10.1	1.9	4.7	4.8
Cycle Q Clear(g_c), s	2.4	0.0	0.4	7.0	0.0	0.0	0.1	0.0	10.1	1.9	4.7	4.8
Prop In Lane	0.31		1.00	0.41		0.34	1.00		0.10	1.00		0.14
Lane Grp Cap(c), veh/h	464	0	329	417	0	0	437	0	592	407	684	701
V/C Ratio(X)	0.23	0.00	0.05	0.53	0.00	0.00	0.02	0.00	0.68	0.25	0.34	0.34
Avail Cap(c_a), veh/h	897	0	751	819	0	0	1097	0	1372	955	1328	1361
HCM Platoon Ratio	1.00	1.00	1.00	1.00	1.00	1.00	1.00	1.00	1.00	1.00	1.00	1.00
Upstream Filter(l)	1.00	0.00	1.00	1.00	0.00	0.00	1.00	0.00	1.00	1.00	1.00	1.00
Uniform Delay (d), s/veh	15.9	0.0	15.1	17.6	0.0	0.0	10.2	0.0	13.7	9.8	9.7	9.8
Incr Delay (d2), s/veh	0.4	0.0	0.1	1.8	0.0	0.0	0.0	0.0	3.0	0.3	0.6	0.6
Initial Q Delay(d3),s/veh	0.0	0.0	0.0	0.0	0.0	0.0	0.0	0.0	0.0	0.0	0.0	0.0
%ile BackOfQ(50%),veh/ln	0.9	0.0	0.1	2.3	0.0	0.0	0.0	0.0	3.6	0.6	1.4	1.5
Unsig. Movement Delay, s/veh												
LnGrp Delay(d),s/veh	16.3	0.0	15.2	19.4	0.0	0.0	10.2	0.0	16.7	10.1	10.4	10.4
LnGrp LOS	B	A	B	B	A	A	B	A	B	B	B	B
Approach Vol, veh/h		122			219			412			575	
Approach Delay, s/veh		16.1			19.4			16.5			10.3	
Approach LOS		B			B			B			B	
Timer - Assigned Phs	1	2		4	5	6		8				
Phs Duration (G+Y+Rc), s	9.3	23.2		16.8	6.0	26.5		16.8				
Change Period (Y+Rc), s	5.5	5.9		5.9	5.5	5.9		5.9				
Max Green Setting (Gmax), s	20.0	40.0		25.0	20.0	40.0		25.0				
Max Q Clear Time (g_c+I1), s	3.9	12.1		4.4	2.1	6.8		9.0				
Green Ext Time (p_c), s	0.2	5.0		0.9	0.0	5.8		1.8				

Intersection Summary

HCM 6th Ctrl Delay	14.3
HCM 6th LOS	B

Notes

User approved pedestrian interval to be less than phase max green.

Lanes, Volumes, Timings
 3: Des Moines Memorial Dr & S 200th St

02/25/2021



Lane Group	EBL	EBT	EBR	WBL	WBT	WBR	NBL	NBT	NBR	SBL	SBT	SBR
Lane Configurations												
Traffic Volume (vph)	21	110	61	18	106	55	17	367	28	11	561	71
Future Volume (vph)	21	110	61	18	106	55	17	367	28	11	561	71
Ideal Flow (vphpl)	1900	1900	1900	1900	1900	1900	1900	1900	1900	1900	1900	1900
Storage Length (ft)	0		200	200		350	200		0	200		0
Storage Lanes	1		1	1		1	1		0	1		0
Taper Length (ft)	25			25			25			25		
Right Turn on Red			Yes			Yes			Yes			Yes
Link Speed (mph)		25			35			35			35	
Link Distance (ft)		533			538			421			545	
Travel Time (s)		14.5			10.5			8.2			10.6	
Confl. Peds. (#/hr)			1	1			1		1	1		1
Peak Hour Factor	0.82	0.82	0.82	0.82	0.82	0.82	0.82	0.82	0.82	0.82	0.82	0.82
Heavy Vehicles (%)	2%	2%	2%	5%	5%	5%	2%	2%	2%	3%	3%	3%
Shared Lane Traffic (%)												
Turn Type	pm+pt	NA		pm+pt	NA	Perm	pm+pt	NA		pm+pt	NA	
Protected Phases	3	8		7	4		5	2		1	6	
Permitted Phases	8			4		4	2			6		
Detector Phase	3	8		7	4	4	5	2		1	6	
Switch Phase												
Minimum Initial (s)	5.0	5.0		5.0	5.0	5.0	5.0	5.0		5.0	5.0	
Minimum Split (s)	10.0	30.0		10.0	31.0	31.0	10.0	32.0		10.0	30.0	
Total Split (s)	25.0	40.0		25.0	40.0	40.0	25.0	55.0		25.0	55.0	
Total Split (%)	17.2%	27.6%		17.2%	27.6%	27.6%	17.2%	37.9%		17.2%	37.9%	
Yellow Time (s)	4.0	4.0		4.0	4.0	4.0	4.0	4.0		4.0	4.0	
All-Red Time (s)	1.0	1.0		1.0	1.0	1.0	1.0	1.0		1.0	1.0	
Lost Time Adjust (s)	0.0	0.0		0.0	0.0	0.0	0.0	0.0		0.0	0.0	
Total Lost Time (s)	5.0	5.0		5.0	5.0	5.0	5.0	5.0		5.0	5.0	
Lead/Lag	Lead	Lag		Lead	Lag	Lag	Lead	Lag		Lead	Lag	
Lead-Lag Optimize?	Yes	Yes		Yes	Yes	Yes	Yes	Yes		Yes	Yes	
Recall Mode	None	None		None	None	None	None	None		None	None	

Intersection Summary

Area Type: Other

Cycle Length: 145

Actuated Cycle Length: 88.9

Natural Cycle: 95





















Control Type: Semi Act-Uncoord

Splits and Phases: 3: Des Moines Memorial Dr & S 200th St



HCM 6th Signalized Intersection Summary
 3: Des Moines Memorial Dr & S 200th St

02/25/2021

												
Movement	EBL	EBT	EBR	WBL	WBT	WBR	NBL	NBT	NBR	SBL	SBT	SBR
Lane Configurations												
Traffic Volume (veh/h)	21	110	61	18	106	55	17	367	28	11	561	71
Future Volume (veh/h)	21	110	61	18	106	55	17	367	28	11	561	71
Initial Q (Qb), veh	0	0	0	0	0	0	0	0	0	0	0	0
Ped-Bike Adj(A_pbT)	1.00		1.00	1.00		1.00	1.00		1.00	1.00		1.00
Parking Bus, Adj	1.00	1.00	1.00	1.00	1.00	1.00	1.00	1.00	1.00	1.00	1.00	1.00
Work Zone On Approach		No			No			No			No	
Adj Sat Flow, veh/h/ln	1870	1870	1870	1826	1826	1826	1870	1870	1870	1856	1856	1856
Adj Flow Rate, veh/h	26	134	74	22	129	67	21	448	34	13	684	87
Peak Hour Factor	0.82	0.82	0.82	0.82	0.82	0.82	0.82	0.82	0.82	0.82	0.82	0.82
Percent Heavy Veh, %	2	2	2	5	5	5	2	2	2	3	3	3
Cap, veh/h	267	191	106	204	303	256	250	899	68	446	832	106
Arrive On Green	0.03	0.17	0.17	0.02	0.17	0.17	0.02	0.52	0.52	0.02	0.52	0.52
Sat Flow, veh/h	1781	1131	625	1739	1826	1543	1781	1716	130	1767	1613	205
Grp Volume(v), veh/h	26	0	208	22	129	67	21	0	482	13	0	771
Grp Sat Flow(s),veh/h/ln	1781	0	1756	1739	1826	1543	1781	0	1847	1767	0	1818
Q Serve(g_s), s	0.9	0.0	8.4	0.8	4.8	2.8	0.4	0.0	12.6	0.3	0.0	26.7
Cycle Q Clear(g_c), s	0.9	0.0	8.4	0.8	4.8	2.8	0.4	0.0	12.6	0.3	0.0	26.7
Prop In Lane	1.00		0.36	1.00		1.00	1.00		0.07	1.00		0.11
Lane Grp Cap(c), veh/h	267	0	297	204	303	256	250	0	967	446	0	938
V/C Ratio(X)	0.10	0.00	0.70	0.11	0.43	0.26	0.08	0.00	0.50	0.03	0.00	0.82
Avail Cap(c_a), veh/h	692	0	819	625	852	720	683	0	1231	889	0	1212
HCM Platoon Ratio	1.00	1.00	1.00	1.00	1.00	1.00	1.00	1.00	1.00	1.00	1.00	1.00
Upstream Filter(l)	1.00	0.00	1.00	1.00	1.00	1.00	1.00	0.00	1.00	1.00	0.00	1.00
Uniform Delay (d), s/veh	24.9	0.0	29.4	25.3	28.1	27.3	12.9	0.0	11.5	9.3	0.0	15.2
Incr Delay (d2), s/veh	0.2	0.0	6.3	0.2	2.0	1.2	0.1	0.0	0.9	0.0	0.0	5.1
Initial Q Delay(d3),s/veh	0.0	0.0	0.0	0.0	0.0	0.0	0.0	0.0	0.0	0.0	0.0	0.0
%ile BackOfQ(50%),veh/ln	0.4	0.0	4.0	0.3	2.2	1.1	0.1	0.0	4.7	0.1	0.0	10.6
Unsig. Movement Delay, s/veh												
LnGrp Delay(d),s/veh	25.1	0.0	35.6	25.6	30.1	28.4	13.1	0.0	12.4	9.3	0.0	20.3
LnGrp LOS	C	A	D	C	C	C	B	A	B	A	A	C
Approach Vol, veh/h		234			218			503			784	
Approach Delay, s/veh		34.4			29.1			12.4			20.1	
Approach LOS		C			C			B			C	
Timer - Assigned Phs	1	2	3	4	5	6	7	8				
Phs Duration (G+Y+Rc), s	6.2	44.3	7.1	17.4	6.8	43.7	6.8	17.7				
Change Period (Y+Rc), s	5.0	5.0	5.0	5.0	5.0	5.0	5.0	5.0				
Max Green Setting (Gmax), s	20.0	50.0	20.0	35.0	20.0	50.0	20.0	35.0				
Max Q Clear Time (g_c+I1), s	2.3	14.6	2.9	6.8	2.4	28.7	2.8	10.4				
Green Ext Time (p_c), s	0.0	6.6	0.0	1.8	0.0	10.0	0.0	2.3				
Intersection Summary												
HCM 6th Ctrl Delay			20.9									
HCM 6th LOS			C									

Lanes, Volumes, Timings
4: 26th Ave S & S 200th St

02/25/2021

Lane Group	EBL	EBT	EBR	WBL	WBT	WBR	NBL	NBT	NBR	SBL	SBT	SBR
Lane Configurations												
Traffic Volume (vph)	6	154	40	71	225	3	42	120	106	33	152	15
Future Volume (vph)	6	154	40	71	225	3	42	120	106	33	152	15
Ideal Flow (vphpl)	1900	1900	1900	1900	1900	1900	1900	1900	1900	1900	1900	1900
Grade (%)		9%			-9%			6%			-7%	
Storage Length (ft)	150		150	175		0	100		0	100		0
Storage Lanes	1		1	1		1	1		0	1		0
Taper Length (ft)	25			25			25			25		
Right Turn on Red			Yes			Yes			Yes			Yes
Link Speed (mph)		35			35			35			35	
Link Distance (ft)		707			875			1004			1058	
Travel Time (s)		13.8			17.0			19.6			20.6	
Confl. Peds. (#/hr)	1		2	2		1						
Peak Hour Factor	0.87	0.87	0.87	0.87	0.87	0.87	0.87	0.87	0.87	0.87	0.87	0.87
Heavy Vehicles (%)	0%	5%	11%	18%	9%	67%	10%	10%	8%	0%	5%	0%
Shared Lane Traffic (%)												
Turn Type	pm+pt	NA		pm+pt	NA	Perm	Perm	NA		Perm	NA	
Protected Phases	3	8		7	4			6			2	
Permitted Phases	8			4		4	6			2		
Detector Phase	3	8		7	4	4	6	6		2	2	
Switch Phase												
Minimum Initial (s)	5.0	10.0		5.0	10.0	10.0	10.0	10.0		10.0	10.0	
Minimum Split (s)	10.0	36.0		10.0	40.0	40.0	35.0	35.0		30.0	30.0	
Total Split (s)	30.0	55.0		30.0	55.0	55.0	55.0	55.0		55.0	55.0	
Total Split (%)	21.4%	39.3%		21.4%	39.3%	39.3%	39.3%	39.3%		39.3%	39.3%	
Yellow Time (s)	4.0	4.0		4.0	4.0	4.0	4.0	4.0		4.0	4.0	
All-Red Time (s)	1.0	1.0		1.0	1.0	1.0	1.0	1.0		1.0	1.0	
Lost Time Adjust (s)	0.0	0.0		0.0	0.0	0.0	0.0	0.0		0.0	0.0	
Total Lost Time (s)	5.0	5.0		5.0	5.0	5.0	5.0	5.0		5.0	5.0	
Lead/Lag	Lead	Lag		Lead	Lag	Lag						
Lead-Lag Optimize?	Yes	Yes		Yes	Yes	Yes						
Recall Mode	None	Min		None	Min	Min	None	None		None	None	

Intersection Summary

Area Type: Other

Cycle Length: 140

Actuated Cycle Length: 41

Natural Cycle: 85

Control Type: Actuated-Uncoordinated

Splits and Phases: 4: 26th Ave S & S 200th St

55 s	30 s	55 s
55 s	30 s	55 s

HCM 6th Signalized Intersection Summary

4: 26th Ave S & S 200th St

02/25/2021

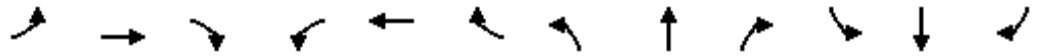

Movement	EBL	EBT	EBR	WBL	WBT	WBR	NBL	NBT	NBR	SBL	SBT	SBR
Lane Configurations												
Traffic Volume (veh/h)	6	154	40	71	225	3	42	120	106	33	152	15
Future Volume (veh/h)	6	154	40	71	225	3	42	120	106	33	152	15
Initial Q (Qb), veh	0	0	0	0	0	0	0	0	0	0	0	0
Ped-Bike Adj(A_pbT)	1.00		1.00	1.00		1.00	1.00		1.00	1.00		1.00
Parking Bus, Adj	1.00		1.00	1.00		1.00	1.00		1.00	1.00		1.00
Work Zone On Approach		No			No			No			No	
Adj Sat Flow, veh/h/ln	1423	1349	1260	1984	2119	1248	1540	1540	1569	2175	2100	2175
Adj Flow Rate, veh/h	7	177	46	82	259	3	48	138	122	38	175	17
Peak Hour Factor	0.87	0.87	0.87	0.87	0.87	0.87	0.87	0.87	0.87	0.87	0.87	0.87
Percent Heavy Veh, %	0	5	11	18	9	67	10	10	8	0	5	0
Cap, veh/h	410	552	140	578	719	358	406	397	325	422	957	92
Arrive On Green	0.01	0.27	0.27	0.08	0.34	0.34	0.26	0.26	0.26	0.26	0.26	0.26
Sat Flow, veh/h	1355	2024	512	1889	2119	1056	981	1528	1250	1302	3678	354
Grp Volume(v), veh/h	7	110	113	82	259	3	48	132	128	38	94	98
Grp Sat Flow(s),veh/h/ln	1355	1281	1255	1889	2119	1056	981	1463	1315	1302	1995	2037
Q Serve(g_s), s	0.1	2.6	2.7	1.1	3.5	0.1	1.5	2.8	3.1	0.9	1.4	1.4
Cycle Q Clear(g_c), s	0.1	2.6	2.7	1.1	3.5	0.1	3.0	2.8	3.1	4.0	1.4	1.4
Prop In Lane	1.00		0.41	1.00		1.00	1.00		0.95	1.00		0.17
Lane Grp Cap(c), veh/h	410	349	342	578	719	358	406	380	342	422	519	530
V/C Ratio(X)	0.02	0.32	0.33	0.14	0.36	0.01	0.12	0.35	0.38	0.09	0.18	0.18
Avail Cap(c_a), veh/h	1282	1671	1637	1667	2764	1378	1430	1908	1715	1782	2603	2657
HCM Platoon Ratio	1.00	1.00	1.00	1.00	1.00	1.00	1.00	1.00	1.00	1.00	1.00	1.00
Upstream Filter(l)	1.00	1.00	1.00	1.00	1.00	1.00	1.00	1.00	1.00	1.00	1.00	1.00
Uniform Delay (d), s/veh	9.9	11.1	11.1	8.6	9.5	8.4	12.2	11.5	11.6	13.3	11.0	11.0
Incr Delay (d2), s/veh	0.0	0.2	0.2	0.0	0.1	0.0	0.0	0.2	0.3	0.0	0.1	0.1
Initial Q Delay(d3),s/veh	0.0	0.0	0.0	0.0	0.0	0.0	0.0	0.0	0.0	0.0	0.0	0.0
%ile BackOfQ(50%),veh/ln	0.0	0.6	0.6	0.3	1.2	0.0	0.3	0.7	0.7	0.2	0.5	0.5
Unsig. Movement Delay, s/veh												
LnGrp Delay(d),s/veh	9.9	11.3	11.3	8.6	9.6	8.4	12.2	11.7	11.9	13.3	11.1	11.1
LnGrp LOS	A	B	B	A	A	A	B	B	B	B	B	B
Approach Vol, veh/h		230			344			308			230	
Approach Delay, s/veh		11.3			9.4			11.9			11.4	
Approach LOS		B			A			B			B	
Timer - Assigned Phs		2	3	4		6	7	8				
Phs Duration (G+Y+Rc), s		15.0	5.4	18.0		15.0	7.9	15.5				
Change Period (Y+Rc), s		5.0	5.0	5.0		5.0	5.0	5.0				
Max Green Setting (Gmax), s		50.0	25.0	50.0		50.0	25.0	50.0				
Max Q Clear Time (g_c+I1), s		6.0	2.1	5.5		5.1	3.1	4.7				
Green Ext Time (p_c), s		0.2	0.0	0.2		0.3	0.0	0.2				
Intersection Summary												
HCM 6th Ctrl Delay			10.9									
HCM 6th LOS			B									

Lanes, Volumes, Timings
 1: Des Moines Memorial Dr & S 192nd St

02/25/2021



Lane Group	EBL	EBT	EBR	WBL	WBT	WBR	NBL	NBT	NBR	SBL	SBT	SBR
Lane Configurations												
Traffic Volume (vph)	19	27	37	42	29	11	18	558	23	10	776	13
Future Volume (vph)	19	27	37	42	29	11	18	558	23	10	776	13
Ideal Flow (vphpl)	1900	1900	1900	1900	1900	1900	1900	1900	1900	1900	1900	1900
Storage Length (ft)	150		0	200		0	150		0	150		0
Storage Lanes	1		0	1		0	1		0	1		0
Taper Length (ft)	25			25			25			25		
Right Turn on Red			Yes			Yes			Yes			Yes
Link Speed (mph)		35			25			35			35	
Link Distance (ft)		1090			1011			616			766	
Travel Time (s)		21.2			27.6			12.0			14.9	
Peak Hour Factor	0.94	0.94	0.94	0.94	0.94	0.94	0.94	0.94	0.94	0.94	0.94	0.94
Heavy Vehicles (%)	16%	7%	0%	8%	3%	18%	11%	1%	17%	90%	1%	23%
Shared Lane Traffic (%)												
Turn Type	pm+pt	NA		pm+pt	NA		Prot	NA		Prot	NA	
Protected Phases	3	8		7	4		5	2		1	6	
Permitted Phases	8			4								
Detector Phase	3	8		7	4		5	2		1	6	
Switch Phase												
Minimum Initial (s)	5.0	5.0		5.0	5.0		6.0	12.0		10.0	12.0	
Minimum Split (s)	10.0	27.0		10.0	10.0		12.0	22.0		16.0	22.0	
Total Split (s)	20.0	35.0		20.0	35.0		21.0	65.0		36.0	65.0	
Total Split (%)	12.8%	22.4%		12.8%	22.4%		13.5%	41.7%		23.1%	41.7%	
Yellow Time (s)	4.0	4.0		4.0	4.0		4.0	4.0		4.0	4.0	
All-Red Time (s)	1.0	1.0		1.0	1.0		2.0	1.0		2.0	1.0	
Lost Time Adjust (s)	0.0	0.0		0.0	0.0		0.0	0.0		0.0	0.0	
Total Lost Time (s)	5.0	5.0		5.0	5.0		6.0	5.0		6.0	5.0	
Lead/Lag	Lead	Lag		Lead	Lag		Lead	Lag		Lead	Lag	
Lead-Lag Optimize?	Yes	Yes		Yes	Yes		Yes	Yes		Yes	Yes	
Recall Mode	None	None		None	None		None	Min		None	Min	

Intersection Summary

Area Type: Other

Cycle Length: 156

Actuated Cycle Length: 72.9

Natural Cycle: 90

Control Type: Actuated-Uncoordinated

Splits and Phases: 1: Des Moines Memorial Dr & S 192nd St

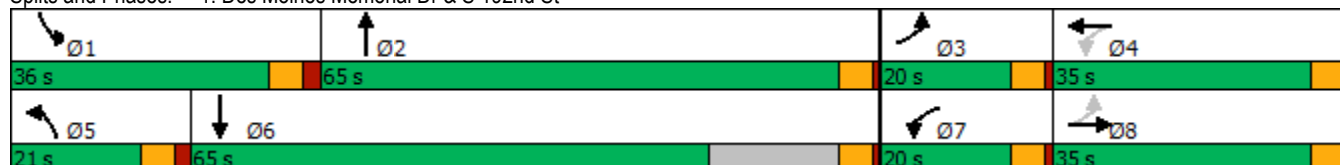

HCM 6th Signalized Intersection Summary

1: Des Moines Memorial Dr & S 192nd St

02/25/2021



Movement	EBL	EBT	EBR	WBL	WBT	WBR	NBL	NBT	NBR	SBL	SBT	SBR
Lane Configurations												
Traffic Volume (veh/h)	19	27	37	42	29	11	18	558	23	10	776	13
Future Volume (veh/h)	19	27	37	42	29	11	18	558	23	10	776	13
Initial Q (Qb), veh	0	0	0	0	0	0	0	0	0	0	0	0
Ped-Bike Adj(A_pbT)	1.00		1.00	1.00		1.00	1.00		1.00	1.00		1.00
Parking Bus, Adj	1.00		1.00	1.00		1.00	1.00		1.00	1.00		1.00
Work Zone On Approach		No			No			No			No	
Adj Sat Flow, veh/h/ln	1663	1796	1900	1781	1856	1633	1737	1885	1648	566	1885	1559
Adj Flow Rate, veh/h	20	29	39	45	31	12	19	594	24	11	826	14
Peak Hour Factor	0.94	0.94	0.94	0.94	0.94	0.94	0.94	0.94	0.94	0.94	0.94	0.94
Percent Heavy Veh, %	16	7	0	8	3	18	11	1	17	90	1	23
Cap, veh/h	229	40	54	221	100	39	45	911	37	15	937	16
Arrive On Green	0.02	0.06	0.06	0.04	0.08	0.08	0.03	0.51	0.51	0.03	0.51	0.51
Sat Flow, veh/h	1584	694	934	1697	1274	493	1654	1799	73	539	1848	31
Grp Volume(v), veh/h	20	0	68	45	0	43	19	0	618	11	0	840
Grp Sat Flow(s),veh/h/ln	1584	0	1628	1697	0	1767	1654	0	1872	539	0	1880
Q Serve(g_s), s	0.7	0.0	2.4	1.4	0.0	1.3	0.7	0.0	14.0	1.2	0.0	23.0
Cycle Q Clear(g_c), s	0.7	0.0	2.4	1.4	0.0	1.3	0.7	0.0	14.0	1.2	0.0	23.0
Prop In Lane	1.00		0.57	1.00		0.28	1.00		0.04	1.00		0.02
Lane Grp Cap(c), veh/h	229	0	94	221	0	138	45	0	948	15	0	953
V/C Ratio(X)	0.09	0.00	0.73	0.20	0.00	0.31	0.42	0.00	0.65	0.73	0.00	0.88
Avail Cap(c_a), veh/h	603	0	846	586	0	918	430	0	1945	280	0	1953
HCM Platoon Ratio	1.00	1.00	1.00	1.00	1.00	1.00	1.00	1.00	1.00	1.00	1.00	1.00
Upstream Filter(l)	1.00	0.00	1.00	1.00	0.00	1.00	1.00	0.00	1.00	1.00	0.00	1.00
Uniform Delay (d), s/veh	24.7	0.0	26.8	24.0	0.0	25.1	27.6	0.0	10.5	27.9	0.0	12.7
Incr Delay (d2), s/veh	0.1	0.0	4.0	0.2	0.0	0.5	2.3	0.0	0.3	86.5	0.0	1.1
Initial Q Delay(d3),s/veh	0.0	0.0	0.0	0.0	0.0	0.0	0.0	0.0	0.0	0.0	0.0	0.0
%ile BackOfQ(50%),veh/ln	0.2	0.0	1.0	0.6	0.0	0.6	0.3	0.0	4.5	0.5	0.0	7.6
Unsig. Movement Delay, s/veh												
LnGrp Delay(d),s/veh	24.7	0.0	30.7	24.1	0.0	25.6	29.9	0.0	10.8	114.4	0.0	13.8
LnGrp LOS	C	A	C	C	A	C	C	A	B	F	A	B
Approach Vol, veh/h		88			88			637				851
Approach Delay, s/veh		29.4			24.9			11.4				15.1
Approach LOS		C			C			B				B
Timer - Assigned Phs	1	2	3	4	5	6	7	8				
Phs Duration (G+Y+Rc), s	7.6	34.2	6.4	9.5	7.6	34.3	7.6	8.3				
Change Period (Y+Rc), s	6.0	5.0	5.0	5.0	6.0	5.0	5.0	5.0				
Max Green Setting (Gmax), s	30.0	60.0	15.0	30.0	15.0	60.0	15.0	30.0				
Max Q Clear Time (g_c+I1), s	3.2	16.0	2.7	3.3	2.7	25.0	3.4	4.4				
Green Ext Time (p_c), s	0.0	2.7	0.0	0.1	0.0	4.3	0.0	0.2				
Intersection Summary												
HCM 6th Ctrl Delay			14.9									
HCM 6th LOS			B									

Lanes, Volumes, Timings
2: 1st Ave S (SR 509) & S 199th St

02/25/2021



Lane Group	EBL	EBT	EBR	WBL	WBT	WBR	NBL	NBT	NBR	SBL	SBT	SBR
Lane Configurations		↕	↗		↕		↗	↕		↗	↕↗	
Traffic Volume (vph)	50	74	9	49	60	71	6	307	53	227	535	26
Future Volume (vph)	50	74	9	49	60	71	6	307	53	227	535	26
Ideal Flow (vphpl)	1750	1750	1750	1750	1750	1750	1750	1750	1750	1750	1750	1750
Storage Length (ft)	0		0	0		0	100		0	150		150
Storage Lanes	0		1	0		0	1		0	1		1
Taper Length (ft)	25			25			25			25		
Right Turn on Red			Yes			Yes			Yes			Yes
Link Speed (mph)		25			25			35			35	
Link Distance (ft)		134			340			192			566	
Travel Time (s)		3.7			9.3			3.7			11.0	
Confl. Peds. (#/hr)	6					6	3					3
Peak Hour Factor	0.88	0.88	0.88	0.88	0.88	0.88	0.88	0.88	0.88	0.88	0.88	0.88
Heavy Vehicles (%)	0%	0%	0%	0%	0%	0%	0%	1%	0%	0%	1%	4%
Shared Lane Traffic (%)												
Turn Type	Perm	NA	Perm	Perm	NA		pm+pt	NA		pm+pt	NA	
Protected Phases		4			8		5	2		1		6
Permitted Phases	4		4	8			2			6		
Detector Phase	4	4	4	8	8		5	2		1		6
Switch Phase												
Minimum Initial (s)	7.0	7.0	7.0	7.0	7.0		5.0	10.0		5.0		10.0
Minimum Split (s)	35.9	35.9	35.9	35.9	35.9		10.5	26.9		10.5		26.9
Total Split (s)	35.9	35.9	35.9	35.9	35.9		25.5	55.9		25.5		55.9
Total Split (%)	30.6%	30.6%	30.6%	30.6%	30.6%		21.7%	47.7%		21.7%		47.7%
Yellow Time (s)	3.9	3.9	3.9	3.9	3.9		3.5	3.9		3.5		3.9
All-Red Time (s)	2.0	2.0	2.0	2.0	2.0		2.0	2.0		2.0		2.0
Lost Time Adjust (s)		0.0	0.0		0.0		0.0	0.0		0.0		0.0
Total Lost Time (s)		5.9	5.9		5.9		5.5	5.9		5.5		5.9
Lead/Lag							Lead	Lag		Lead		Lag
Lead-Lag Optimize?							Yes	Yes		Yes		Yes
Recall Mode	None	None	None	None	None		None	Min		None		Min

Intersection Summary

Area Type: Other

Cycle Length: 117.3

Actuated Cycle Length: 72.6

Natural Cycle: 80

Control Type: Actuated-Uncoordinated

Splits and Phases: 2: 1st Ave S (SR 509) & S 199th St

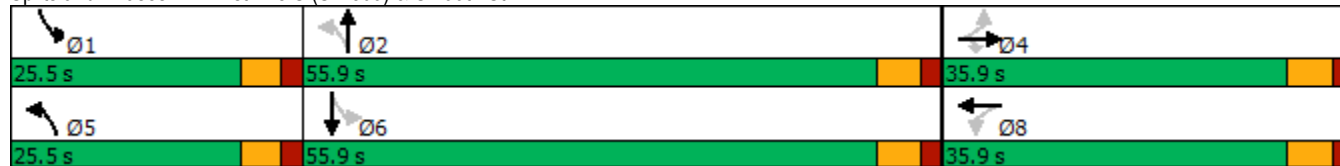

HCM 6th Signalized Intersection Summary
 2: 1st Ave S (SR 509) & S 199th St

02/25/2021



Movement	EBL	EBT	EBR	WBL	WBT	WBR	NBL	NBT	NBR	SBL	SBT	SBR
Lane Configurations		↕	↗		↕		↗	↕		↗	↕↗	
Traffic Volume (veh/h)	50	74	9	49	60	71	6	307	53	227	535	26
Future Volume (veh/h)	50	74	9	49	60	71	6	307	53	227	535	26
Initial Q (Qb), veh	0	0	0	0	0	0	0	0	0	0	0	0
Ped-Bike Adj(A_pbT)	0.99		0.99	0.99		0.99	1.00		1.00	1.00		1.00
Parking Bus, Adj	1.00	1.00	1.00	1.00	1.00	1.00	1.00	1.00	1.00	1.00	1.00	1.00
Work Zone On Approach		No			No			No			No	
Adj Sat Flow, veh/h/ln	1750	1750	1750	1750	1750	1750	1750	1736	1750	1750	1736	1695
Adj Flow Rate, veh/h	57	84	10	56	68	81	7	349	60	258	608	30
Peak Hour Factor	0.88	0.88	0.88	0.88	0.88	0.88	0.88	0.88	0.88	0.88	0.88	0.88
Percent Heavy Veh, %	0	0	0	0	0	0	0	1	0	0	1	4
Cap, veh/h	196	245	327	141	138	130	392	492	85	467	1488	73
Arrive On Green	0.22	0.22	0.22	0.22	0.22	0.22	0.01	0.34	0.34	0.13	0.47	0.47
Sat Flow, veh/h	481	1100	1471	274	621	585	1667	1442	248	1667	3199	158
Grp Volume(v), veh/h	141	0	10	205	0	0	7	0	409	258	313	325
Grp Sat Flow(s),veh/h/ln	1581	0	1471	1480	0	0	1667	0	1690	1667	1650	1707
Q Serve(g_s), s	0.0	0.0	0.3	3.1	0.0	0.0	0.2	0.0	12.0	5.1	7.2	7.2
Cycle Q Clear(g_c), s	4.0	0.0	0.3	7.0	0.0	0.0	0.2	0.0	12.0	5.1	7.2	7.2
Prop In Lane	0.40		1.00	0.27		0.40	1.00		0.15	1.00		0.09
Lane Grp Cap(c), veh/h	440	0	327	410	0	0	392	0	577	467	767	794
V/C Ratio(X)	0.32	0.00	0.03	0.50	0.00	0.00	0.02	0.00	0.71	0.55	0.41	0.41
Avail Cap(c_a), veh/h	878	0	773	852	0	0	961	0	1481	830	1445	1496
HCM Platoon Ratio	1.00	1.00	1.00	1.00	1.00	1.00	1.00	1.00	1.00	1.00	1.00	1.00
Upstream Filter(l)	1.00	0.00	1.00	1.00	0.00	0.00	1.00	0.00	1.00	1.00	1.00	1.00
Uniform Delay (d), s/veh	18.8	0.0	17.4	19.9	0.0	0.0	12.1	0.0	16.3	10.5	10.1	10.1
Incr Delay (d2), s/veh	0.7	0.0	0.1	1.6	0.0	0.0	0.0	0.0	3.4	1.0	0.7	0.7
Initial Q Delay(d3),s/veh	0.0	0.0	0.0	0.0	0.0	0.0	0.0	0.0	0.0	0.0	0.0	0.0
%ile BackOfQ(50%),veh/ln	1.6	0.0	0.1	2.5	0.0	0.0	0.1	0.0	4.5	1.5	2.2	2.3
Unsig. Movement Delay, s/veh												
LnGrp Delay(d),s/veh	19.5	0.0	17.4	21.5	0.0	0.0	12.1	0.0	19.7	11.5	10.8	10.8
LnGrp LOS	B	A	B	C	A	A	B	A	B	B	B	B
Approach Vol, veh/h		151			205			416			896	
Approach Delay, s/veh		19.3			21.5			19.6			11.0	
Approach LOS		B			C			B			B	
Timer - Assigned Phs	1	2		4	5	6		8				
Phs Duration (G+Y+Rc), s	13.1	25.4		18.6	6.0	32.5		18.6				
Change Period (Y+Rc), s	5.5	5.9		5.9	5.5	5.9		5.9				
Max Green Setting (Gmax), s	20.0	50.0		30.0	20.0	50.0		30.0				
Max Q Clear Time (g_c+I1), s	7.1	14.0		6.0	2.2	9.2		9.0				
Green Ext Time (p_c), s	0.6	5.5		1.4	0.0	8.8		1.9				
Intersection Summary												
HCM 6th Ctrl Delay			15.2									
HCM 6th LOS			B									

Lanes, Volumes, Timings
 3: Des Moines Memorial Dr & S 200th St

02/25/2021



Lane Group	EBL	EBT	EBR	WBL	WBT	WBR	NBL	NBT	NBR	SBL	SBT	SBR
Lane Configurations												
Traffic Volume (vph)	27	186	141	67	156	52	13	340	29	82	711	11
Future Volume (vph)	27	186	141	67	156	52	13	340	29	82	711	11
Ideal Flow (vphpl)	1900	1900	1900	1900	1900	1900	1900	1900	1900	1900	1900	1900
Storage Length (ft)	0		200	200		350	200		0	200		0
Storage Lanes	1		1	1		1	1		0	1		0
Taper Length (ft)	25			25			25			25		
Right Turn on Red			Yes			Yes			Yes			Yes
Link Speed (mph)		25			35			35			35	
Link Distance (ft)		533			538			421			545	
Travel Time (s)		14.5			10.5			8.2			10.6	
Confl. Peds. (#/hr)			3	3								
Peak Hour Factor	0.98	0.98	0.98	0.98	0.98	0.98	0.98	0.98	0.98	0.98	0.98	0.98
Heavy Vehicles (%)	0%	1%	5%	2%	4%	4%	25%	2%	4%	7%	1%	0%
Shared Lane Traffic (%)												
Turn Type	pm+pt	NA		pm+pt	NA	Perm	pm+pt	NA		pm+pt	NA	
Protected Phases	3	8		7	4		5	2		1	6	
Permitted Phases	8			4		4	2			6		
Detector Phase	3	8		7	4	4	5	2		1	6	
Switch Phase												
Minimum Initial (s)	5.0	5.0		5.0	5.0	5.0	5.0	5.0		5.0	5.0	
Minimum Split (s)	10.0	30.0		10.0	31.0	31.0	10.0	32.0		10.0	30.0	
Total Split (s)	25.0	40.0		25.0	40.0	40.0	25.0	55.0		25.0	55.0	
Total Split (%)	17.2%	27.6%		17.2%	27.6%	27.6%	17.2%	37.9%		17.2%	37.9%	
Yellow Time (s)	4.0	4.0		4.0	4.0	4.0	4.0	4.0		4.0	4.0	
All-Red Time (s)	1.0	1.0		1.0	1.0	1.0	1.0	1.0		1.0	1.0	
Lost Time Adjust (s)	0.0	0.0		0.0	0.0	0.0	0.0	0.0		0.0	0.0	
Total Lost Time (s)	5.0	5.0		5.0	5.0	5.0	5.0	5.0		5.0	5.0	
Lead/Lag	Lead	Lag		Lead	Lag	Lag	Lead	Lag		Lead	Lag	
Lead-Lag Optimize?	Yes	Yes		Yes	Yes	Yes	Yes	Yes		Yes	Yes	
Recall Mode	None	None		None	None	None	None	None		None	None	

Intersection Summary

Area Type: Other

Cycle Length: 145

Actuated Cycle Length: 102.8

Natural Cycle: 85

Control Type: Actuated-Uncoordinated

Splits and Phases: 3: Des Moines Memorial Dr & S 200th St



HCM 6th Signalized Intersection Summary
 3: Des Moines Memorial Dr & S 200th St

02/25/2021



Movement	EBL	EBT	EBR	WBL	WBT	WBR	NBL	NBT	NBR	SBL	SBT	SBR
Lane Configurations												
Traffic Volume (veh/h)	27	186	141	67	156	52	13	340	29	82	711	11
Future Volume (veh/h)	27	186	141	67	156	52	13	340	29	82	711	11
Initial Q (Qb), veh	0	0	0	0	0	0	0	0	0	0	0	0
Ped-Bike Adj(A_pbT)	1.00		0.99	1.00		0.99	1.00		1.00	1.00		1.00
Parking Bus, Adj	1.00	1.00	1.00	1.00	1.00	1.00	1.00	1.00	1.00	1.00	1.00	1.00
Work Zone On Approach		No			No			No			No	
Adj Sat Flow, veh/h/ln	1900	1885	1826	1870	1841	1841	1530	1870	1841	1796	1885	1900
Adj Flow Rate, veh/h	28	190	144	68	159	53	13	347	30	84	726	11
Peak Hour Factor	0.98	0.98	0.98	0.98	0.98	0.98	0.98	0.98	0.98	0.98	0.98	0.98
Percent Heavy Veh, %	0	1	5	2	4	4	25	2	4	7	1	0
Cap, veh/h	361	242	184	233	482	407	176	730	63	442	861	13
Arrive On Green	0.03	0.24	0.24	0.05	0.26	0.26	0.02	0.43	0.43	0.05	0.46	0.46
Sat Flow, veh/h	1810	992	752	1781	1841	1551	1457	1697	147	1711	1852	28
Grp Volume(v), veh/h	28	0	334	68	159	53	13	0	377	84	0	737
Grp Sat Flow(s),veh/h/ln	1810	0	1744	1781	1841	1551	1457	0	1844	1711	0	1880
Q Serve(g_s), s	1.0	0.0	15.6	2.5	6.1	2.3	0.4	0.0	12.8	2.3	0.0	30.1
Cycle Q Clear(g_c), s	1.0	0.0	15.6	2.5	6.1	2.3	0.4	0.0	12.8	2.3	0.0	30.1
Prop In Lane	1.00		0.43	1.00		1.00	1.00		0.08	1.00		0.01
Lane Grp Cap(c), veh/h	361	0	426	233	482	407	176	0	794	442	0	874
V/C Ratio(X)	0.08	0.00	0.78	0.29	0.33	0.13	0.07	0.00	0.48	0.19	0.00	0.84
Avail Cap(c_a), veh/h	725	0	700	559	739	623	487	0	1058	749	0	1078
HCM Platoon Ratio	1.00	1.00	1.00	1.00	1.00	1.00	1.00	1.00	1.00	1.00	1.00	1.00
Upstream Filter(l)	1.00	0.00	1.00	1.00	1.00	1.00	1.00	0.00	1.00	1.00	0.00	1.00
Uniform Delay (d), s/veh	23.6	0.0	30.8	24.3	26.0	24.6	17.8	0.0	17.8	13.4	0.0	20.5
Incr Delay (d2), s/veh	0.1	0.0	6.7	0.7	0.8	0.3	0.2	0.0	0.9	0.2	0.0	6.7
Initial Q Delay(d3),s/veh	0.0	0.0	0.0	0.0	0.0	0.0	0.0	0.0	0.0	0.0	0.0	0.0
%ile BackOfQ(50%),veh/ln	0.4	0.0	7.2	1.0	2.7	0.9	0.1	0.0	5.3	0.9	0.0	13.6
Unsig. Movement Delay, s/veh												
LnGrp Delay(d),s/veh	23.7	0.0	37.5	25.0	26.8	24.9	18.0	0.0	18.7	13.6	0.0	27.2
LnGrp LOS	C	A	D	C	C	C	B	A	B	B	A	C
Approach Vol, veh/h		362			280			390			821	
Approach Delay, s/veh		36.4			26.0			18.7			25.8	
Approach LOS		D			C			B			C	
Timer - Assigned Phs	1	2	3	4	5	6	7	8				
Phs Duration (G+Y+Rc), s	9.3	42.5	7.5	27.8	6.4	45.5	9.0	26.3				
Change Period (Y+Rc), s	5.0	5.0	5.0	5.0	5.0	5.0	5.0	5.0				
Max Green Setting (Gmax), s	20.0	50.0	20.0	35.0	20.0	50.0	20.0	35.0				
Max Q Clear Time (g_c+I1), s	4.3	14.8	3.0	8.1	2.4	32.1	4.5	17.6				
Green Ext Time (p_c), s	0.1	4.9	0.0	2.0	0.0	8.4	0.1	3.5				
Intersection Summary												
HCM 6th Ctrl Delay			26.4									
HCM 6th LOS			C									

Lanes, Volumes, Timings
4: 26th Ave S & S 200th St

02/25/2021

Lane Group	EBL	EBT	EBR	WBL	WBT	WBR	NBL	NBT	NBR	SBL	SBT	SBR
Lane Configurations												
Traffic Volume (vph)	15	276	83	82	357	7	100	130	52	30	270	11
Future Volume (vph)	15	276	83	82	357	7	100	130	52	30	270	11
Ideal Flow (vphpl)	1900	1900	1900	1900	1900	1900	1900	1900	1900	1900	1900	1900
Grade (%)		9%			-9%			6%			-7%	
Storage Length (ft)	150		150	175		0	100		0	100		0
Storage Lanes	1		1	1		1	1		0	1		0
Taper Length (ft)	25			25			25			25		
Right Turn on Red			Yes			Yes			Yes			Yes
Link Speed (mph)		35			35			35			35	
Link Distance (ft)		707			875			1004			1058	
Travel Time (s)		13.8			17.0			19.6			20.6	
Confl. Peds. (#/hr)	1		1	1		1			1	1		
Peak Hour Factor	0.94	0.94	0.94	0.94	0.94	0.94	0.94	0.94	0.94	0.94	0.94	0.94
Heavy Vehicles (%)	0%	1%	1%	13%	4%	29%	2%	8%	12%	0%	3%	0%
Shared Lane Traffic (%)												
Turn Type	pm+pt	NA		pm+pt	NA	Perm	Perm	NA		Perm	NA	
Protected Phases	3	8		7	4			6			2	
Permitted Phases	8			4		4	6			2		
Detector Phase	3	8		7	4	4	6	6		2	2	
Switch Phase												
Minimum Initial (s)	5.0	10.0		5.0	10.0	10.0	10.0	10.0		10.0	10.0	
Minimum Split (s)	10.0	36.0		10.0	40.0	40.0	35.0	35.0		30.0	30.0	
Total Split (s)	30.0	55.0		30.0	55.0	55.0	55.0	55.0		55.0	55.0	
Total Split (%)	21.4%	39.3%		21.4%	39.3%	39.3%	39.3%	39.3%		39.3%	39.3%	
Yellow Time (s)	4.0	4.0		4.0	4.0	4.0	4.0	4.0		4.0	4.0	
All-Red Time (s)	1.0	1.0		1.0	1.0	1.0	1.0	1.0		1.0	1.0	
Lost Time Adjust (s)	0.0	0.0		0.0	0.0	0.0	0.0	0.0		0.0	0.0	
Total Lost Time (s)	5.0	5.0		5.0	5.0	5.0	5.0	5.0		5.0	5.0	
Lead/Lag	Lead	Lag		Lead	Lag	Lag						
Lead-Lag Optimize?	Yes	Yes		Yes	Yes	Yes						
Recall Mode	None	Min		None	Min	Min	None	None		None	None	

Intersection Summary

Area Type: Other

Cycle Length: 140

Actuated Cycle Length: 45.5

Natural Cycle: 85

Control Type: Actuated-Uncoordinated

Splits and Phases: 4: 26th Ave S & S 200th St

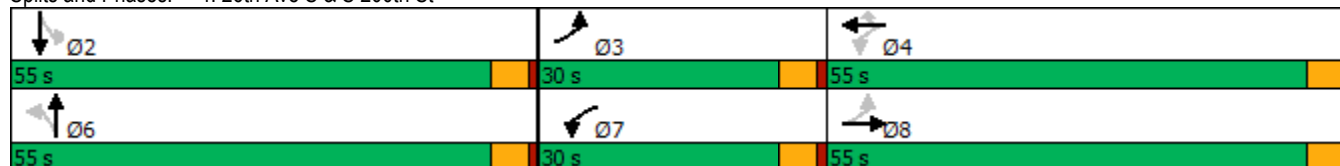

HCM 6th Signalized Intersection Summary

4: 26th Ave S & S 200th St

02/25/2021

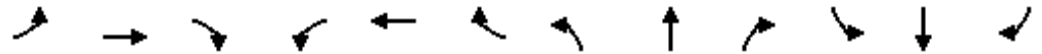

Movement	EBL	EBT	EBR	WBL	WBT	WBR	NBL	NBT	NBR	SBL	SBT	SBR
Lane Configurations												
Traffic Volume (veh/h)	15	276	83	82	357	7	100	130	52	30	270	11
Future Volume (veh/h)	15	276	83	82	357	7	100	130	52	30	270	11
Initial Q (Qb), veh	0	0	0	0	0	0	0	0	0	0	0	0
Ped-Bike Adj(A_pbT)	1.00		1.00	1.00		1.00	1.00		1.00	1.00		1.00
Parking Bus, Adj	1.00	1.00	1.00	1.00	1.00	1.00	1.00	1.00	1.00	1.00	1.00	1.00
Work Zone On Approach		No			No			No			No	
Adj Sat Flow, veh/h/ln	1423	1408	1408	2059	2194	1819	1658	1569	1510	2175	2130	2175
Adj Flow Rate, veh/h	16	294	88	87	380	7	106	138	55	32	287	12
Peak Hour Factor	0.94	0.94	0.94	0.94	0.94	0.94	0.94	0.94	0.94	0.94	0.94	0.94
Percent Heavy Veh, %	0	1	1	13	4	29	2	8	12	0	3	0
Cap, veh/h	353	542	159	495	711	499	386	560	214	480	1051	44
Arrive On Green	0.02	0.27	0.27	0.08	0.32	0.32	0.27	0.27	0.27	0.27	0.27	0.27
Sat Flow, veh/h	1355	2038	599	1961	2194	1540	957	2109	805	1383	3959	165
Grp Volume(v), veh/h	16	191	191	87	380	7	106	96	97	32	146	153
Grp Sat Flow(s),veh/h/ln	1355	1338	1300	1961	2194	1540	957	1491	1423	1383	2024	2100
Q Serve(g_s), s	0.3	4.7	4.9	1.2	5.4	0.1	3.8	1.9	2.1	0.7	2.2	2.2
Cycle Q Clear(g_c), s	0.3	4.7	4.9	1.2	5.4	0.1	6.0	1.9	2.1	2.8	2.2	2.2
Prop In Lane	1.00		0.46	1.00		1.00	1.00		0.57	1.00		0.08
Lane Grp Cap(c), veh/h	353	356	346	495	711	499	386	396	378	480	537	557
V/C Ratio(X)	0.05	0.54	0.55	0.18	0.53	0.01	0.27	0.24	0.26	0.07	0.27	0.27
Avail Cap(c_a), veh/h	1207	1739	1689	1615	2852	2002	1376	1938	1851	1911	2631	2730
HCM Platoon Ratio	1.00	1.00	1.00	1.00	1.00	1.00	1.00	1.00	1.00	1.00	1.00	1.00
Upstream Filter(l)	1.00	1.00	1.00	1.00	1.00	1.00	1.00	1.00	1.00	1.00	1.00	1.00
Uniform Delay (d), s/veh	10.0	12.1	12.1	9.0	10.6	8.8	13.6	11.1	11.1	12.2	11.2	11.2
Incr Delay (d2), s/veh	0.0	0.5	0.5	0.1	0.2	0.0	0.1	0.1	0.1	0.0	0.1	0.1
Initial Q Delay(d3),s/veh	0.0	0.0	0.0	0.0	0.0	0.0	0.0	0.0	0.0	0.0	0.0	0.0
%ile BackOfQ(50%),veh/ln	0.1	1.1	1.1	0.4	1.9	0.0	0.7	0.5	0.5	0.2	0.8	0.8
Unsig. Movement Delay, s/veh												
LnGrp Delay(d),s/veh	10.1	12.6	12.7	9.0	10.9	8.8	13.7	11.2	11.3	12.3	11.3	11.3
LnGrp LOS	B	B	B	A	B	A	B	B	B	B	B	B
Approach Vol, veh/h		398			474			299			331	
Approach Delay, s/veh		12.5			10.5			12.1			11.4	
Approach LOS		B			B			B			B	
Timer - Assigned Phs		2	3	4		6	7	8				
Phs Duration (G+Y+Rc), s		15.2	5.8	17.5		15.2	8.0	15.2				
Change Period (Y+Rc), s		5.0	5.0	5.0		5.0	5.0	5.0				
Max Green Setting (Gmax), s		50.0	25.0	50.0		50.0	25.0	50.0				
Max Q Clear Time (g_c+I1), s		4.8	2.3	7.4		8.0	3.2	6.9				
Green Ext Time (p_c), s		0.2	0.0	0.3		0.3	0.0	0.4				
Intersection Summary												
HCM 6th Ctrl Delay				11.5								
HCM 6th LOS				B								

2023 Without Project

Lanes, Volumes, Timings
 1: Des Moines Memorial Dr & S 192nd St

02/25/2021



Lane Group	EBL	EBT	EBR	WBL	WBT	WBR	NBL	NBT	NBR	SBL	SBT	SBR
Lane Configurations												
Traffic Volume (vph)	15	31	30	11	31	17	103	1096	80	6	275	11
Future Volume (vph)	15	31	30	11	31	17	103	1096	80	6	275	11
Ideal Flow (vphpl)	1900	1900	1900	1900	1900	1900	1900	1900	1900	1900	1900	1900
Storage Length (ft)	150		0	200		0	150		0	150		0
Storage Lanes	1		0	1		0	1		0	1		0
Taper Length (ft)	25			25			25			25		
Right Turn on Red			Yes			Yes			Yes			Yes
Link Speed (mph)		35			25			35			35	
Link Distance (ft)		1090			1011			616			766	
Travel Time (s)		21.2			27.6			12.0			14.9	
Confl. Peds. (#/hr)			2	2					1			
Peak Hour Factor	0.92	0.92	0.92	0.92	0.92	0.92	0.92	0.92	0.92	0.92	0.92	0.92
Heavy Vehicles (%)	14%	23%	15%	20%	7%	50%	2%	2%	3%	17%	7%	9%
Shared Lane Traffic (%)												
Turn Type	pm+pt	NA		pm+pt	NA		Prot	NA		Prot	NA	
Protected Phases	3	8		7	4		5	2		1	6	
Permitted Phases	8			4								
Detector Phase	3	8		7	4		5	2		1	6	
Switch Phase												
Minimum Initial (s)	5.0	5.0		5.0	5.0		6.0	12.0		10.0	12.0	
Minimum Split (s)	10.0	27.0		10.0	10.0		12.0	22.0		16.0	22.0	
Total Split (s)	20.0	35.0		20.0	35.0		21.0	65.0		36.0	65.0	
Total Split (%)	12.8%	22.4%		12.8%	22.4%		13.5%	41.7%		23.1%	41.7%	
Yellow Time (s)	4.0	4.0		4.0	4.0		4.0	4.0		4.0	4.0	
All-Red Time (s)	1.0	1.0		1.0	1.0		2.0	1.0		2.0	1.0	
Lost Time Adjust (s)	0.0	0.0		0.0	0.0		0.0	0.0		0.0	0.0	
Total Lost Time (s)	5.0	5.0		5.0	5.0		6.0	5.0		6.0	5.0	
Lead/Lag	Lead	Lag		Lead	Lag		Lead	Lag		Lead	Lag	
Lead-Lag Optimize?	Yes	Yes		Yes	Yes		Yes	Yes		Yes	Yes	
Recall Mode	None	None		None	None		None	Min		None	Min	

Intersection Summary

Area Type: Other

Cycle Length: 156

Actuated Cycle Length: 85.5

Natural Cycle: 150

Control Type: Actuated-Uncoordinated

Splits and Phases: 1: Des Moines Memorial Dr & S 192nd St

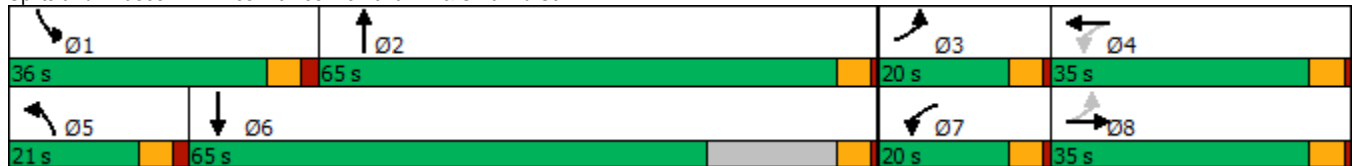

HCM 6th Signalized Intersection Summary

1: Des Moines Memorial Dr & S 192nd St

02/25/2021

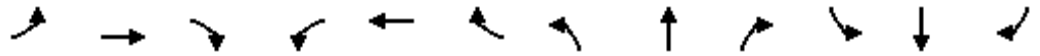

Movement	EBL	EBT	EBR	WBL	WBT	WBR	NBL	NBT	NBR	SBL	SBT	SBR
Lane Configurations												
Traffic Volume (veh/h)	15	31	30	11	31	17	103	1096	80	6	275	11
Future Volume (veh/h)	15	31	30	11	31	17	103	1096	80	6	275	11
Initial Q (Qb), veh	0	0	0	0	0	0	0	0	0	0	0	0
Ped-Bike Adj(A_pbT)	0.99		0.98	0.99		0.98	1.00		1.00	1.00		1.00
Parking Bus, Adj	1.00	1.00	1.00	1.00	1.00	1.00	1.00	1.00	1.00	1.00	1.00	1.00
Work Zone On Approach		No			No			No			No	
Adj Sat Flow, veh/h/ln	1693	1559	1678	1604	1796	1159	1870	1870	1856	1648	1796	1767
Adj Flow Rate, veh/h	16	34	33	12	34	18	112	1191	87	7	299	12
Peak Hour Factor	0.92	0.92	0.92	0.92	0.92	0.92	0.92	0.92	0.92	0.92	0.92	0.92
Percent Heavy Veh, %	14	23	15	20	7	50	2	2	3	17	7	9
Cap, veh/h	144	45	44	120	64	34	142	1155	84	28	1044	42
Arrive On Green	0.02	0.06	0.06	0.01	0.06	0.06	0.08	0.67	0.67	0.02	0.61	0.61
Sat Flow, veh/h	1612	720	699	1527	1098	581	1781	1722	126	1570	1715	69
Grp Volume(v), veh/h	16	0	67	12	0	52	112	0	1278	7	0	311
Grp Sat Flow(s),veh/h/ln	1612	0	1420	1527	0	1680	1781	0	1848	1570	0	1784
Q Serve(g_s), s	0.8	0.0	4.2	0.7	0.0	2.7	5.5	0.0	60.0	0.4	0.0	7.4
Cycle Q Clear(g_c), s	0.8	0.0	4.2	0.7	0.0	2.7	5.5	0.0	60.0	0.4	0.0	7.4
Prop In Lane	1.00		0.49	1.00		0.35	1.00		0.07	1.00		0.04
Lane Grp Cap(c), veh/h	144	0	88	120	0	98	142	0	1239	28	0	1086
V/C Ratio(X)	0.11	0.00	0.76	0.10	0.00	0.53	0.79	0.00	1.03	0.25	0.00	0.29
Avail Cap(c_a), veh/h	385	0	476	354	0	563	299	0	1239	526	0	1197
HCM Platoon Ratio	1.00	1.00	1.00	1.00	1.00	1.00	1.00	1.00	1.00	1.00	1.00	1.00
Upstream Filter(l)	1.00	0.00	1.00	1.00	0.00	1.00	1.00	0.00	1.00	1.00	0.00	1.00
Uniform Delay (d), s/veh	38.6	0.0	41.3	38.8	0.0	40.9	40.4	0.0	14.7	43.3	0.0	8.3
Incr Delay (d2), s/veh	0.1	0.0	4.9	0.1	0.0	1.7	3.7	0.0	33.9	9.6	0.0	0.1
Initial Q Delay(d3),s/veh	0.0	0.0	0.0	0.0	0.0	0.0	0.0	0.0	0.0	0.0	0.0	0.0
%ile BackOfQ(50%),veh/ln	0.3	0.0	1.5	0.3	0.0	1.2	2.5	0.0	30.8	0.2	0.0	2.5
Unsig. Movement Delay, s/veh												
LnGrp Delay(d),s/veh	38.7	0.0	46.2	39.0	0.0	42.6	44.1	0.0	48.6	53.0	0.0	8.3
LnGrp LOS	D	A	D	D	A	D	D	A	F	D	A	A
Approach Vol, veh/h		83			64			1390				318
Approach Delay, s/veh		44.7			41.9			48.3				9.3
Approach LOS		D			D			D				A
Timer - Assigned Phs	1	2	3	4	5	6	7	8				
Phs Duration (G+Y+Rc), s	7.6	65.0	6.6	10.2	13.1	59.5	6.3	10.6				
Change Period (Y+Rc), s	6.0	5.0	5.0	5.0	6.0	5.0	5.0	5.0				
Max Green Setting (Gmax), s	30.0	60.0	15.0	30.0	15.0	60.0	15.0	30.0				
Max Q Clear Time (g_c+I1), s	2.4	62.0	2.8	4.7	7.5	9.4	2.7	6.2				
Green Ext Time (p_c), s	0.0	0.0	0.0	0.1	0.1	1.2	0.0	0.2				
Intersection Summary												
HCM 6th Ctrl Delay			41.2									
HCM 6th LOS			D									

Lanes, Volumes, Timings
2: 1st Ave S (SR 509) & S 199th St

02/25/2021



Lane Group	EBL	EBT	EBR	WBL	WBT	WBR	NBL	NBT	NBR	SBL	SBT	SBR
Lane Configurations		↕	↗		↕		↗	↕		↗	↕	↗
Traffic Volume (vph)	26	21	4	26	53	95	10	349	71	112	190	21
Future Volume (vph)	26	21	4	26	53	95	10	349	71	112	190	21
Ideal Flow (vphpl)	1750	1750	1750	1750	1750	1750	1750	1750	1750	1750	1750	1750
Storage Length (ft)	0		0	0		0	100		0	150		150
Storage Lanes	0		1	0		0	1		0	1		1
Taper Length (ft)	25			25			25			25		
Right Turn on Red			Yes			Yes			Yes			Yes
Link Speed (mph)		25			25			35				35
Link Distance (ft)		134			340			192				566
Travel Time (s)		3.7			9.3			3.7				11.0
Confl. Peds. (#/hr)	3					3	2					2
Peak Hour Factor	1.00	1.00	1.00	1.00	1.00	1.00	1.00	1.00	1.00	1.00	1.00	1.00
Heavy Vehicles (%)	0%	0%	25%	0%	10%	17%	0%	2%	0%	6%	2%	0%
Shared Lane Traffic (%)												
Turn Type	Perm	NA	Perm	Perm	NA		pm+pt	NA		pm+pt	NA	
Protected Phases		4			8		5	2		1		6
Permitted Phases	4		4	8			2			6		
Detector Phase	4	4	4	8	8		5	2		1		6
Switch Phase												
Minimum Initial (s)	7.0	7.0	7.0	7.0	7.0		5.0	10.0		5.0		10.0
Minimum Split (s)	35.9	35.9	35.9	35.9	35.9		10.5	26.9		10.5		26.9
Total Split (s)	35.9	35.9	35.9	35.9	35.9		25.5	55.9		25.5		55.9
Total Split (%)	30.6%	30.6%	30.6%	30.6%	30.6%		21.7%	47.7%		21.7%		47.7%
Yellow Time (s)	3.9	3.9	3.9	3.9	3.9		3.5	3.9		3.5		3.9
All-Red Time (s)	2.0	2.0	2.0	2.0	2.0		2.0	2.0		2.0		2.0
Lost Time Adjust (s)		0.0	0.0		0.0		0.0	0.0		0.0		0.0
Total Lost Time (s)		5.9	5.9		5.9		5.5	5.9		5.5		5.9
Lead/Lag							Lead	Lag		Lead		Lag
Lead-Lag Optimize?							Yes	Yes		Yes		Yes
Recall Mode	None	None	None	None	None		None	Min		None		Min

Intersection Summary

Area Type: Other

Cycle Length: 117.3

Actuated Cycle Length: 64

Natural Cycle: 75

Control Type: Actuated-Uncoordinated

Splits and Phases: 2: 1st Ave S (SR 509) & S 199th St



HCM 6th Signalized Intersection Summary
 2: 1st Ave S (SR 509) & S 199th St

02/25/2021

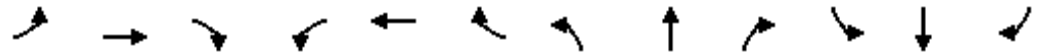

Movement	EBL	EBT	EBR	WBL	WBT	WBR	NBL	NBT	NBR	SBL	SBT	SBR
Lane Configurations		↕	↗		↕		↗	↕		↗	↕↗	
Traffic Volume (veh/h)	26	21	4	26	53	95	10	349	71	112	190	21
Future Volume (veh/h)	26	21	4	26	53	95	10	349	71	112	190	21
Initial Q (Qb), veh	0	0	0	0	0	0	0	0	0	0	0	0
Ped-Bike Adj(A_pbT)	1.00		1.00	1.00		0.99	1.00		1.00	1.00		1.00
Parking Bus, Adj	1.00	1.00	1.00	1.00	1.00	1.00	1.00	1.00	1.00	1.00	1.00	1.00
Work Zone On Approach		No			No			No			No	
Adj Sat Flow, veh/h/ln	1750	1750	1409	1750	1614	1518	1750	1723	1750	1668	1723	1750
Adj Flow Rate, veh/h	26	21	4	26	53	95	10	349	71	112	190	21
Peak Hour Factor	1.00	1.00	1.00	1.00	1.00	1.00	1.00	1.00	1.00	1.00	1.00	1.00
Percent Heavy Veh, %	0	0	25	0	10	17	0	2	0	6	2	0
Cap, veh/h	251	167	231	108	102	151	575	515	105	412	1302	142
Arrive On Green	0.19	0.19	0.19	0.19	0.19	0.19	0.01	0.37	0.37	0.08	0.44	0.44
Sat Flow, veh/h	702	859	1188	119	528	778	1667	1388	282	1589	2975	325
Grp Volume(v), veh/h	47	0	4	174	0	0	10	0	420	112	104	107
Grp Sat Flow(s),veh/h/ln	1561	0	1188	1424	0	0	1667	0	1671	1589	1637	1663
Q Serve(g_s), s	0.0	0.0	0.1	1.3	0.0	0.0	0.2	0.0	10.3	2.0	1.8	1.9
Cycle Q Clear(g_c), s	1.1	0.0	0.1	5.4	0.0	0.0	0.2	0.0	10.3	2.0	1.8	1.9
Prop In Lane	0.55		1.00	0.15		0.55	1.00		0.17	1.00		0.20
Lane Grp Cap(c), veh/h	418	0	231	362	0	0	575	0	619	412	716	728
V/C Ratio(X)	0.11	0.00	0.02	0.48	0.00	0.00	0.02	0.00	0.68	0.27	0.14	0.15
Avail Cap(c_a), veh/h	992	0	732	950	0	0	1237	0	1715	937	1680	1707
HCM Platoon Ratio	1.00	1.00	1.00	1.00	1.00	1.00	1.00	1.00	1.00	1.00	1.00	1.00
Upstream Filter(l)	1.00	0.00	1.00	1.00	0.00	0.00	1.00	0.00	1.00	1.00	1.00	1.00
Uniform Delay (d), s/veh	16.3	0.0	15.9	18.0	0.0	0.0	9.3	0.0	12.9	9.2	8.2	8.2
Incr Delay (d2), s/veh	0.2	0.0	0.1	1.7	0.0	0.0	0.0	0.0	2.8	0.4	0.2	0.2
Initial Q Delay(d3),s/veh	0.0	0.0	0.0	0.0	0.0	0.0	0.0	0.0	0.0	0.0	0.0	0.0
%ile BackOfQ(50%),veh/ln	0.4	0.0	0.0	1.8	0.0	0.0	0.1	0.0	3.5	0.6	0.5	0.6
Unsig. Movement Delay, s/veh												
LnGrp Delay(d),s/veh	16.5	0.0	15.9	19.7	0.0	0.0	9.3	0.0	15.7	9.5	8.4	8.4
LnGrp LOS	B	A	B	B	A	A	A	A	B	A	A	A
Approach Vol, veh/h		51			174			430			323	
Approach Delay, s/veh		16.4			19.7			15.5			8.8	
Approach LOS		B			B			B			A	
Timer - Assigned Phs	1	2		4	5	6		8				
Phs Duration (G+Y+Rc), s	9.4	24.0		15.4	6.1	27.2		15.4				
Change Period (Y+Rc), s	5.5	5.9		5.9	5.5	5.9		5.9				
Max Green Setting (Gmax), s	20.0	50.0		30.0	20.0	50.0		30.0				
Max Q Clear Time (g_c+I1), s	4.0	12.3		3.1	2.2	3.9		7.4				
Green Ext Time (p_c), s	0.2	5.7		0.4	0.0	2.5		1.7				
Intersection Summary												
HCM 6th Ctrl Delay			14.1									
HCM 6th LOS			B									

Lanes, Volumes, Timings
 3: Des Moines Memorial Dr & S 200th St

02/25/2021



Lane Group	EBL	EBT	EBR	WBL	WBT	WBR	NBL	NBT	NBR	SBL	SBT	SBR
Lane Configurations												
Traffic Volume (vph)	28	143	33	18	132	284	35	956	59	70	265	7
Future Volume (vph)	28	143	33	18	132	284	35	956	59	70	265	7
Ideal Flow (vphpl)	1900	1900	1900	1900	1900	1900	1900	1900	1900	1900	1900	1900
Storage Length (ft)	0		200	200		350	200		0	200		0
Storage Lanes	1		1	1		1	1		0	1		0
Taper Length (ft)	25			25			25			25		
Right Turn on Red			Yes			Yes			Yes			Yes
Link Speed (mph)		25			35			35			35	
Link Distance (ft)		533			538			421			545	
Travel Time (s)		14.5			10.5			8.2			10.6	
Confl. Peds. (#/hr)	8		1	1		8	3					3
Peak Hour Factor	0.95	0.95	0.95	0.95	0.95	0.95	0.95	0.95	0.95	0.95	0.95	0.95
Heavy Vehicles (%)	3%	3%	3%	3%	3%	3%	1%	1%	1%	1%	1%	1%
Shared Lane Traffic (%)												
Turn Type	pm+pt	NA		pm+pt	NA	Perm	pm+pt	NA		pm+pt	NA	
Protected Phases	3	8		7	4		5	2		1	6	
Permitted Phases	8			4		4	2			6		
Detector Phase	3	8		7	4	4	5	2		1	6	
Switch Phase												
Minimum Initial (s)	5.0	5.0		5.0	5.0	5.0	5.0	5.0		5.0	5.0	
Minimum Split (s)	10.0	30.0		10.0	31.0	31.0	10.0	32.0		10.0	30.0	
Total Split (s)	25.0	40.0		25.0	40.0	40.0	25.0	55.0		25.0	55.0	
Total Split (%)	17.2%	27.6%		17.2%	27.6%	27.6%	17.2%	37.9%		17.2%	37.9%	
Yellow Time (s)	4.0	4.0		4.0	4.0	4.0	4.0	4.0		4.0	4.0	
All-Red Time (s)	1.0	1.0		1.0	1.0	1.0	1.0	1.0		1.0	1.0	
Lost Time Adjust (s)	0.0	0.0		0.0	0.0	0.0	0.0	0.0		0.0	0.0	
Total Lost Time (s)	5.0	5.0		5.0	5.0	5.0	5.0	5.0		5.0	5.0	
Lead/Lag	Lead	Lag		Lead	Lag	Lag	Lead	Lag		Lead	Lag	
Lead-Lag Optimize?	Yes	Yes		Yes	Yes	Yes	Yes	Yes		Yes	Yes	
Recall Mode	None	None		None	None	None	None	None		None	None	

Intersection Summary

Area Type: Other

Cycle Length: 145

Actuated Cycle Length: 94.7

Natural Cycle: 125

Control Type: Actuated-Uncoordinated

Splits and Phases: 3: Des Moines Memorial Dr & S 200th St

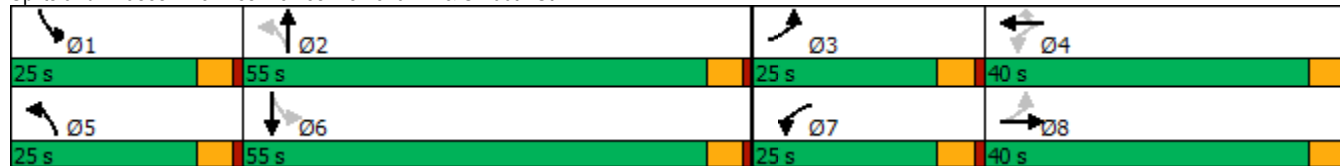

HCM 6th Signalized Intersection Summary
 3: Des Moines Memorial Dr & S 200th St

02/25/2021



Movement	EBL	EBT	EBR	WBL	WBT	WBR	NBL	NBT	NBR	SBL	SBT	SBR
Lane Configurations												
Traffic Volume (veh/h)	28	143	33	18	132	284	35	956	59	70	265	7
Future Volume (veh/h)	28	143	33	18	132	284	35	956	59	70	265	7
Initial Q (Qb), veh	0	0	0	0	0	0	0	0	0	0	0	0
Ped-Bike Adj(A_pbT)	0.99		0.98	0.99		0.98	1.00		1.00	1.00		1.00
Parking Bus, Adj	1.00	1.00	1.00	1.00	1.00	1.00	1.00	1.00	1.00	1.00	1.00	1.00
Work Zone On Approach		No			No			No			No	
Adj Sat Flow, veh/h/ln	1856	1856	1856	1856	1856	1856	1885	1885	1885	1885	1885	1885
Adj Flow Rate, veh/h	29	151	35	19	139	299	37	1006	62	74	279	7
Peak Hour Factor	0.95	0.95	0.95	0.95	0.95	0.95	0.95	0.95	0.95	0.95	0.95	0.95
Percent Heavy Veh, %	3	3	3	3	3	3	1	1	1	1	1	1
Cap, veh/h	284	354	82	291	439	366	588	869	54	149	926	23
Arrive On Green	0.03	0.24	0.24	0.02	0.24	0.24	0.03	0.49	0.49	0.04	0.51	0.51
Sat Flow, veh/h	1767	1452	337	1767	1856	1546	1795	1757	108	1795	1831	46
Grp Volume(v), veh/h	29	0	186	19	139	299	37	0	1068	74	0	286
Grp Sat Flow(s),veh/h/ln	1767	0	1788	1767	1856	1546	1795	0	1865	1795	0	1877
Q Serve(g_s), s	1.2	0.0	8.9	0.8	6.2	18.5	1.0	0.0	50.0	2.0	0.0	9.0
Cycle Q Clear(g_c), s	1.2	0.0	8.9	0.8	6.2	18.5	1.0	0.0	50.0	2.0	0.0	9.0
Prop In Lane	1.00		0.19	1.00		1.00	1.00		0.06	1.00		0.02
Lane Grp Cap(c), veh/h	284	0	436	291	439	366	588	0	923	149	0	950
V/C Ratio(X)	0.10	0.00	0.43	0.07	0.32	0.82	0.06	0.00	1.16	0.50	0.00	0.30
Avail Cap(c_a), veh/h	584	0	619	604	643	535	885	0	923	426	0	950
HCM Platoon Ratio	1.00	1.00	1.00	1.00	1.00	1.00	1.00	1.00	1.00	1.00	1.00	1.00
Upstream Filter(l)	1.00	0.00	1.00	1.00	1.00	1.00	1.00	0.00	1.00	1.00	0.00	1.00
Uniform Delay (d), s/veh	28.0	0.0	32.3	28.5	31.8	36.5	11.9	0.0	25.5	23.6	0.0	14.6
Incr Delay (d2), s/veh	0.2	0.0	1.4	0.1	0.9	10.3	0.0	0.0	83.1	2.6	0.0	0.4
Initial Q Delay(d3),s/veh	0.0	0.0	0.0	0.0	0.0	0.0	0.0	0.0	0.0	0.0	0.0	0.0
%ile BackOfQ(50%),veh/ln	0.5	0.0	4.0	0.3	2.9	8.0	0.4	0.0	41.5	0.9	0.0	3.7
Unsig. Movement Delay, s/veh												
LnGrp Delay(d),s/veh	28.2	0.0	33.7	28.6	32.7	46.8	11.9	0.0	108.6	26.2	0.0	14.9
LnGrp LOS	C	A	C	C	C	D	B	A	F	C	A	B
Approach Vol, veh/h		215			457			1105				360
Approach Delay, s/veh		32.9			41.8			105.4				17.2
Approach LOS		C			D			F				B
Timer - Assigned Phs	1	2	3	4	5	6	7	8				
Phs Duration (G+Y+Rc), s	9.4	55.0	7.8	28.9	8.2	56.1	7.1	29.6				
Change Period (Y+Rc), s	5.0	5.0	5.0	5.0	5.0	5.0	5.0	5.0				
Max Green Setting (Gmax), s	20.0	50.0	20.0	35.0	20.0	50.0	20.0	35.0				
Max Q Clear Time (g_c+I1), s	4.0	52.0	3.2	20.5	3.0	11.0	2.8	10.9				
Green Ext Time (p_c), s	0.1	0.0	0.0	3.2	0.0	3.6	0.0	2.0				
Intersection Summary												
HCM 6th Ctrl Delay			69.6									
HCM 6th LOS			E									

Lanes, Volumes, Timings
4: 26th Ave S & S 200th St

02/25/2021



Lane Group	EBL	EBT	EBR	WBL	WBT	WBR	NBL	NBT	NBR	SBL	SBT	SBR
Lane Configurations												
Traffic Volume (vph)	32	222	33	51	349	7	78	153	40	5	68	8
Future Volume (vph)	32	222	33	51	349	7	78	153	40	5	68	8
Ideal Flow (vphpl)	1900	1900	1900	1900	1900	1900	1900	1900	1900	1900	1900	1900
Grade (%)		9%			-9%			6%			-7%	
Storage Length (ft)	150		150	175		0	100		0	100		0
Storage Lanes	1		1	1		1	1		0	1		0
Taper Length (ft)	25			25			25			25		
Right Turn on Red			Yes			Yes			Yes			Yes
Link Speed (mph)		35			35			35			35	
Link Distance (ft)		707			875			1004			1058	
Travel Time (s)		13.8			17.0			19.6			20.6	
Confl. Peds. (#/hr)	1					1						
Peak Hour Factor	0.96	0.96	0.96	0.96	0.96	0.96	0.96	0.96	0.96	0.96	0.96	0.96
Heavy Vehicles (%)	18%	11%	11%	25%	9%	29%	5%	8%	34%	0%	5%	0%
Shared Lane Traffic (%)												
Turn Type	pm+pt	NA		pm+pt	NA	Perm	Perm	NA		Perm	NA	
Protected Phases	3	8		7	4			6			2	
Permitted Phases	8			4		4	6			2		
Detector Phase	3	8		7	4	4	6	6		2	2	
Switch Phase												
Minimum Initial (s)	5.0	10.0		5.0	10.0	10.0	10.0	10.0		10.0	10.0	
Minimum Split (s)	10.0	36.0		10.0	40.0	40.0	35.0	35.0		30.0	30.0	
Total Split (s)	30.0	55.0		30.0	55.0	55.0	55.0	55.0		55.0	55.0	
Total Split (%)	21.4%	39.3%		21.4%	39.3%	39.3%	39.3%	39.3%		39.3%	39.3%	
Yellow Time (s)	4.0	4.0		4.0	4.0	4.0	4.0	4.0		4.0	4.0	
All-Red Time (s)	1.0	1.0		1.0	1.0	1.0	1.0	1.0		1.0	1.0	
Lost Time Adjust (s)	0.0	0.0		0.0	0.0	0.0	0.0	0.0		0.0	0.0	
Total Lost Time (s)	5.0	5.0		5.0	5.0	5.0	5.0	5.0		5.0	5.0	
Lead/Lag	Lead	Lag		Lead	Lag	Lag						
Lead-Lag Optimize?	Yes	Yes		Yes	Yes	Yes						
Recall Mode	None	Min		None	Min	Min	None	None		None	None	

Intersection Summary

Area Type: Other

Cycle Length: 140

Actuated Cycle Length: 41.6

Natural Cycle: 85

Control Type: Actuated-Uncoordinated

Splits and Phases: 4: 26th Ave S & S 200th St

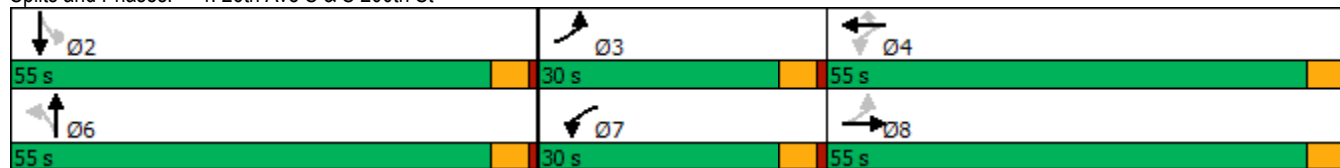

HCM 6th Signalized Intersection Summary
 4: 26th Ave S & S 200th St

02/25/2021



Movement	EBL	EBT	EBR	WBL	WBT	WBR	NBL	NBT	NBR	SBL	SBT	SBR
Lane Configurations												
Traffic Volume (veh/h)	32	222	33	51	349	7	78	153	40	5	68	8
Future Volume (veh/h)	32	222	33	51	349	7	78	153	40	5	68	8
Initial Q (Qb), veh	0	0	0	0	0	0	0	0	0	0	0	0
Ped-Bike Adj(A_pbT)	1.00		1.00	1.00		1.00	1.00		1.00	1.00		1.00
Parking Bus, Adj	1.00	1.00	1.00	1.00	1.00	1.00	1.00	1.00	1.00	1.00	1.00	1.00
Work Zone On Approach		No			No			No			No	
Adj Sat Flow, veh/h/ln	1156	1260	1260	1879	2119	1819	1614	1569	1184	2175	2100	2175
Adj Flow Rate, veh/h	33	231	34	53	364	7	81	159	42	5	71	8
Peak Hour Factor	0.96	0.96	0.96	0.96	0.96	0.96	0.96	0.96	0.96	0.96	0.96	0.96
Percent Heavy Veh, %	18	11	11	25	9	29	5	8	34	0	5	0
Cap, veh/h	329	578	84	502	622	452	477	619	159	480	954	106
Arrive On Green	0.04	0.28	0.28	0.06	0.29	0.29	0.26	0.26	0.26	0.26	0.26	0.26
Sat Flow, veh/h	1101	2097	305	1789	2119	1540	1139	2349	603	1374	3622	402
Grp Volume(v), veh/h	33	131	134	53	364	7	81	99	102	5	39	40
Grp Sat Flow(s),veh/h/ln	1101	1197	1205	1789	2119	1540	1139	1491	1461	1374	1995	2028
Q Serve(g_s), s	0.8	3.3	3.4	0.8	5.4	0.1	2.1	1.9	2.0	0.1	0.5	0.6
Cycle Q Clear(g_c), s	0.8	3.3	3.4	0.8	5.4	0.1	2.7	1.9	2.0	2.2	0.5	0.6
Prop In Lane	1.00		0.25	1.00		1.00	1.00		0.41	1.00		0.20
Lane Grp Cap(c), veh/h	329	330	332	502	622	452	477	393	385	480	526	534
V/C Ratio(X)	0.10	0.40	0.41	0.11	0.59	0.02	0.17	0.25	0.26	0.01	0.07	0.08
Avail Cap(c_a), veh/h	1028	1613	1624	1606	2856	2075	1712	2010	1969	1970	2690	2734
HCM Platoon Ratio	1.00	1.00	1.00	1.00	1.00	1.00	1.00	1.00	1.00	1.00	1.00	1.00
Upstream Filter(l)	1.00	1.00	1.00	1.00	1.00	1.00	1.00	1.00	1.00	1.00	1.00	1.00
Uniform Delay (d), s/veh	9.3	10.9	11.0	8.7	11.2	9.3	11.3	10.8	10.8	11.7	10.3	10.3
Incr Delay (d2), s/veh	0.0	0.3	0.3	0.0	0.3	0.0	0.1	0.1	0.1	0.0	0.0	0.0
Initial Q Delay(d3),s/veh	0.0	0.0	0.0	0.0	0.0	0.0	0.0	0.0	0.0	0.0	0.0	0.0
%ile BackOfQ(50%),veh/ln	0.1	0.7	0.7	0.2	1.9	0.0	0.4	0.5	0.5	0.0	0.2	0.2
Unsig. Movement Delay, s/veh												
LnGrp Delay(d),s/veh	9.4	11.2	11.3	8.7	11.5	9.3	11.3	10.9	11.0	11.7	10.3	10.3
LnGrp LOS	A	B	B	A	B	A	B	B	B	B	B	B
Approach Vol, veh/h		298			424			282				84
Approach Delay, s/veh		11.0			11.1			11.0				10.4
Approach LOS		B			B			B				B
Timer - Assigned Phs		2	3	4		6	7	8				
Phs Duration (G+Y+Rc), s		14.8	6.4	15.9		14.8	7.1	15.2				
Change Period (Y+Rc), s		5.0	5.0	5.0		5.0	5.0	5.0				
Max Green Setting (Gmax), s		50.0	25.0	50.0		50.0	25.0	50.0				
Max Q Clear Time (g_c+I1), s		4.2	2.8	7.4		4.7	2.8	5.4				
Green Ext Time (p_c), s		0.1	0.0	0.3		0.2	0.0	0.2				
Intersection Summary												
HCM 6th Ctrl Delay				11.0								
HCM 6th LOS				B								

Lanes, Volumes, Timings
 1: Des Moines Memorial Dr & S 192nd St

02/25/2021



Lane Group	EBL	EBT	EBR	WBL	WBT	WBR	NBL	NBT	NBR	SBL	SBT	SBR
Lane Configurations												
Traffic Volume (vph)	9	30	35	58	31	16	22	484	46	11	618	9
Future Volume (vph)	9	30	35	58	31	16	22	484	46	11	618	9
Ideal Flow (vphpl)	1900	1900	1900	1900	1900	1900	1900	1900	1900	1900	1900	1900
Storage Length (ft)	150		0	200		0	150		0	150		0
Storage Lanes	1		0	1		0	1		0	1		0
Taper Length (ft)	25			25			25			25		
Right Turn on Red			Yes			Yes			Yes			Yes
Link Speed (mph)		35			25			35			35	
Link Distance (ft)		1090			1011			616			766	
Travel Time (s)		21.2			27.6			12.0			14.9	
Confl. Peds. (#/hr)			2	2					1			
Peak Hour Factor	0.84	0.84	0.84	0.84	0.84	0.84	0.84	0.84	0.84	0.84	0.84	0.84
Heavy Vehicles (%)	22%	3%	12%	7%	23%	13%	8%	6%	16%	46%	2%	22%
Shared Lane Traffic (%)												
Turn Type	pm+pt	NA		pm+pt	NA		Prot	NA		Prot	NA	
Protected Phases	3	8		7	4		5	2		1	6	
Permitted Phases	8			4								
Detector Phase	3	8		7	4		5	2		1	6	
Switch Phase												
Minimum Initial (s)	5.0	5.0		5.0	5.0		6.0	12.0		10.0	12.0	
Minimum Split (s)	10.0	27.0		10.0	10.0		12.0	22.0		16.0	22.0	
Total Split (s)	20.0	35.0		20.0	35.0		21.0	65.0		36.0	65.0	
Total Split (%)	12.8%	22.4%		12.8%	22.4%		13.5%	41.7%		23.1%	41.7%	
Yellow Time (s)	4.0	4.0		4.0	4.0		4.0	4.0		4.0	4.0	
All-Red Time (s)	1.0	1.0		1.0	1.0		2.0	1.0		2.0	1.0	
Lost Time Adjust (s)	0.0	0.0		0.0	0.0		0.0	0.0		0.0	0.0	
Total Lost Time (s)	5.0	5.0		5.0	5.0		6.0	5.0		6.0	5.0	
Lead/Lag	Lead	Lag		Lead	Lag		Lead	Lag		Lead	Lag	
Lead-Lag Optimize?	Yes	Yes		Yes	Yes		Yes	Yes		Yes	Yes	
Recall Mode	None	None		None	None		None	Min		None	Min	

Intersection Summary

Area Type: Other

Cycle Length: 156

Actuated Cycle Length: 78.5

Natural Cycle: 90

Control Type: Actuated-Uncoordinated

Splits and Phases: 1: Des Moines Memorial Dr & S 192nd St

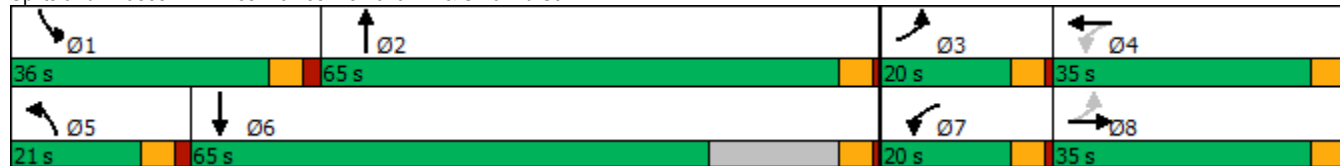

HCM 6th Signalized Intersection Summary

1: Des Moines Memorial Dr & S 192nd St

02/25/2021

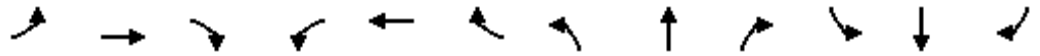

Movement	EBL	EBT	EBR	WBL	WBT	WBR	NBL	NBT	NBR	SBL	SBT	SBR
Lane Configurations												
Traffic Volume (veh/h)	9	30	35	58	31	16	22	484	46	11	618	9
Future Volume (veh/h)	9	30	35	58	31	16	22	484	46	11	618	9
Initial Q (Qb), veh	0	0	0	0	0	0	0	0	0	0	0	0
Ped-Bike Adj(A_pbT)	0.99		0.99	0.99		0.99	1.00		1.00	1.00		1.00
Parking Bus, Adj	1.00	1.00	1.00	1.00	1.00	1.00	1.00	1.00	1.00	1.00	1.00	1.00
Work Zone On Approach		No			No			No			No	
Adj Sat Flow, veh/h/ln	1574	1856	1722	1796	1559	1707	1781	1811	1663	1218	1870	1574
Adj Flow Rate, veh/h	11	36	42	69	37	19	26	576	55	13	736	11
Peak Hour Factor	0.84	0.84	0.84	0.84	0.84	0.84	0.84	0.84	0.84	0.84	0.84	0.84
Percent Heavy Veh, %	22	3	12	7	23	13	8	6	16	46	2	22
Cap, veh/h	226	53	62	259	109	56	61	754	72	38	846	13
Arrive On Green	0.01	0.07	0.07	0.06	0.11	0.11	0.04	0.46	0.46	0.03	0.46	0.46
Sat Flow, veh/h	1499	776	905	1711	968	497	1697	1628	155	1160	1838	27
Grp Volume(v), veh/h	11	0	78	69	0	56	26	0	631	13	0	747
Grp Sat Flow(s),veh/h/ln	1499	0	1681	1711	0	1464	1697	0	1783	1160	0	1865
Q Serve(g_s), s	0.4	0.0	2.5	2.0	0.0	2.0	0.8	0.0	16.4	0.6	0.0	20.1
Cycle Q Clear(g_c), s	0.4	0.0	2.5	2.0	0.0	2.0	0.8	0.0	16.4	0.6	0.0	20.1
Prop In Lane	1.00		0.54	1.00		0.34	1.00		0.09	1.00		0.01
Lane Grp Cap(c), veh/h	226	0	114	259	0	165	61	0	826	38	0	859
V/C Ratio(X)	0.05	0.00	0.68	0.27	0.00	0.34	0.43	0.00	0.76	0.34	0.00	0.87
Avail Cap(c_a), veh/h	609	0	905	618	0	788	457	0	1920	625	0	2009
HCM Platoon Ratio	1.00	1.00	1.00	1.00	1.00	1.00	1.00	1.00	1.00	1.00	1.00	1.00
Upstream Filter(l)	1.00	0.00	1.00	1.00	0.00	1.00	1.00	0.00	1.00	1.00	0.00	1.00
Uniform Delay (d), s/veh	23.6	0.0	25.4	22.2	0.0	22.8	26.3	0.0	12.4	26.4	0.0	13.5
Incr Delay (d2), s/veh	0.0	0.0	2.7	0.2	0.0	0.4	1.8	0.0	0.6	11.0	0.0	1.1
Initial Q Delay(d3),s/veh	0.0	0.0	0.0	0.0	0.0	0.0	0.0	0.0	0.0	0.0	0.0	0.0
%ile BackOfQ(50%),veh/ln	0.1	0.0	1.0	0.8	0.0	0.7	0.3	0.0	5.2	0.3	0.0	6.8
Unsig. Movement Delay, s/veh												
LnGrp Delay(d),s/veh	23.7	0.0	28.0	22.4	0.0	23.2	28.1	0.0	13.0	37.4	0.0	14.6
LnGrp LOS	C	A	C	C	A	C	C	A	B	D	A	B
Approach Vol, veh/h		89			125			657			760	
Approach Delay, s/veh		27.5			22.8			13.6			15.0	
Approach LOS		C			C			B			B	
Timer - Assigned Phs	1	2	3	4	5	6	7	8				
Phs Duration (G+Y+Rc), s	7.8	30.8	5.8	11.3	8.0	30.7	8.3	8.8				
Change Period (Y+Rc), s	6.0	5.0	5.0	5.0	6.0	5.0	5.0	5.0				
Max Green Setting (Gmax), s	30.0	60.0	15.0	30.0	15.0	60.0	15.0	30.0				
Max Q Clear Time (g_c+I1), s	2.6	18.4	2.4	4.0	2.8	22.1	4.0	4.5				
Green Ext Time (p_c), s	0.0	2.9	0.0	0.2	0.0	3.6	0.0	0.2				
Intersection Summary												
HCM 6th Ctrl Delay			15.7									
HCM 6th LOS			B									

Lanes, Volumes, Timings
2: 1st Ave S (SR 509) & S 199th St

02/25/2021



Lane Group	EBL	EBT	EBR	WBL	WBT	WBR	NBL	NBT	NBR	SBL	SBT	SBR
Lane Configurations		↕	↗		↕		↗	↕		↗	↕↗	
Traffic Volume (vph)	30	67	16	83	50	70	6	338	37	96	406	31
Future Volume (vph)	30	67	16	83	50	70	6	338	37	96	406	31
Ideal Flow (vphpl)	1750	1750	1750	1750	1750	1750	1750	1750	1750	1750	1750	1750
Storage Length (ft)	0		0	0		0	100		0	150		150
Storage Lanes	0		1	0		0	1		0	1		1
Taper Length (ft)	25			25			25			25		
Right Turn on Red			Yes			Yes			Yes			Yes
Link Speed (mph)		25			25			35				35
Link Distance (ft)		134			340			192				566
Travel Time (s)		3.7			9.3			3.7				11.0
Confl. Peds. (#/hr)	1		1	1		1	7		1	1		7
Peak Hour Factor	1.00	1.00	1.00	1.00	1.00	1.00	1.00	1.00	1.00	1.00	1.00	1.00
Heavy Vehicles (%)	0%	0%	0%	7%	0%	0%	0%	2%	0%	0%	2%	0%
Shared Lane Traffic (%)												
Turn Type	Perm	NA	Perm	Perm	NA		pm+pt	NA		pm+pt	NA	
Protected Phases		4			8		5	2		1		6
Permitted Phases	4		4	8			2			6		
Detector Phase	4	4	4	8	8		5	2		1		6
Switch Phase												
Minimum Initial (s)	7.0	7.0	7.0	7.0	7.0		5.0	10.0		5.0		10.0
Minimum Split (s)	35.9	35.9	35.9	35.9	35.9		10.5	26.9		10.5		26.9
Total Split (s)	30.9	30.9	30.9	30.9	30.9		25.5	45.9		25.5		45.9
Total Split (%)	30.2%	30.2%	30.2%	30.2%	30.2%		24.9%	44.9%		24.9%		44.9%
Yellow Time (s)	3.9	3.9	3.9	3.9	3.9		3.5	3.9		3.5		3.9
All-Red Time (s)	2.0	2.0	2.0	2.0	2.0		2.0	2.0		2.0		2.0
Lost Time Adjust (s)		0.0	0.0		0.0		0.0	0.0		0.0		0.0
Total Lost Time (s)		5.9	5.9		5.9		5.5	5.9		5.5		5.9
Lead/Lag							Lead	Lag		Lead		Lag
Lead-Lag Optimize?							Yes	Yes		Yes		Yes
Recall Mode	None	None	None	None	None		None	Min		None		Min

Intersection Summary

Area Type: Other

Cycle Length: 102.3

Actuated Cycle Length: 62

Natural Cycle: 75

Control Type: Actuated-Uncoordinated

Splits and Phases: 2: 1st Ave S (SR 509) & S 199th St

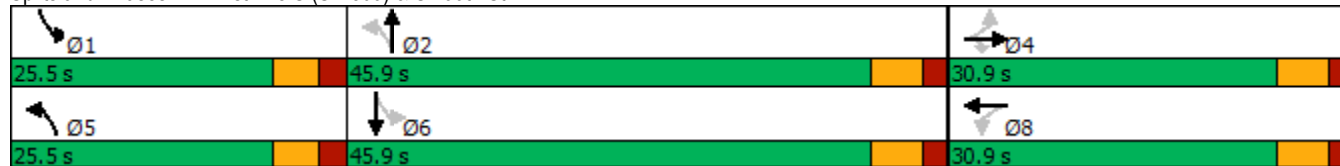

HCM 6th Signalized Intersection Summary
 2: 1st Ave S (SR 509) & S 199th St

02/25/2021

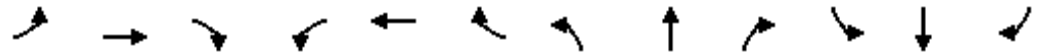

Movement	EBL	EBT	EBR	WBL	WBT	WBR	NBL	NBT	NBR	SBL	SBT	SBR
Lane Configurations		↕	↗		↕		↖	↗		↖	↕	↗
Traffic Volume (veh/h)	30	67	16	83	50	70	6	338	37	96	406	31
Future Volume (veh/h)	30	67	16	83	50	70	6	338	37	96	406	31
Initial Q (Qb), veh	0	0	0	0	0	0	0	0	0	0	0	0
Ped-Bike Adj(A_pbT)	1.00		1.00	1.00		1.00	0.99		0.99	1.00		0.99
Parking Bus, Adj	1.00	1.00	1.00	1.00	1.00	1.00	1.00	1.00	1.00	1.00	1.00	1.00
Work Zone On Approach		No			No			No			No	
Adj Sat Flow, veh/h/ln	1750	1750	1750	1654	1750	1750	1750	1723	1750	1750	1723	1750
Adj Flow Rate, veh/h	30	67	16	83	50	70	6	338	37	96	406	31
Peak Hour Factor	1.00	1.00	1.00	1.00	1.00	1.00	1.00	1.00	1.00	1.00	1.00	1.00
Percent Heavy Veh, %	0	0	0	7	0	0	0	2	0	0	2	0
Cap, veh/h	166	284	311	205	103	104	450	515	56	424	1252	95
Arrive On Green	0.21	0.21	0.21	0.21	0.21	0.21	0.01	0.34	0.34	0.08	0.41	0.41
Sat Flow, veh/h	304	1353	1481	451	490	495	1667	1524	167	1667	3080	234
Grp Volume(v), veh/h	97	0	16	203	0	0	6	0	375	96	215	222
Grp Sat Flow(s),veh/h/ln	1657	0	1481	1436	0	0	1667	0	1691	1667	1637	1678
Q Serve(g_s), s	0.0	0.0	0.4	3.8	0.0	0.0	0.1	0.0	8.7	1.6	4.1	4.2
Cycle Q Clear(g_c), s	2.1	0.0	0.4	5.9	0.0	0.0	0.1	0.0	8.7	1.6	4.1	4.2
Prop In Lane	0.31		1.00	0.41		0.34	1.00		0.10	1.00		0.14
Lane Grp Cap(c), veh/h	450	0	311	412	0	0	450	0	571	424	665	682
V/C Ratio(X)	0.22	0.00	0.05	0.49	0.00	0.00	0.01	0.00	0.66	0.23	0.32	0.33
Avail Cap(c_a), veh/h	958	0	803	882	0	0	1160	0	1468	1020	1421	1457
HCM Platoon Ratio	1.00	1.00	1.00	1.00	1.00	1.00	1.00	1.00	1.00	1.00	1.00	1.00
Upstream Filter(l)	1.00	0.00	1.00	1.00	0.00	0.00	1.00	0.00	1.00	1.00	1.00	1.00
Uniform Delay (d), s/veh	15.2	0.0	14.5	16.7	0.0	0.0	9.9	0.0	13.0	9.3	9.3	9.4
Incr Delay (d2), s/veh	0.4	0.0	0.1	1.6	0.0	0.0	0.0	0.0	2.7	0.3	0.6	0.6
Initial Q Delay(d3),s/veh	0.0	0.0	0.0	0.0	0.0	0.0	0.0	0.0	0.0	0.0	0.0	0.0
%ile BackOfQ(50%),veh/ln	0.8	0.0	0.1	1.9	0.0	0.0	0.0	0.0	3.0	0.5	1.2	1.3
Unsig. Movement Delay, s/veh												
LnGrp Delay(d),s/veh	15.6	0.0	14.7	18.2	0.0	0.0	9.9	0.0	15.7	9.6	9.9	9.9
LnGrp LOS	B	A	B	B	A	A	A	A	B	A	A	A
Approach Vol, veh/h		113			203			381			533	
Approach Delay, s/veh		15.5			18.2			15.6			9.9	
Approach LOS		B			B			B			A	
Timer - Assigned Phs	1	2		4	5	6		8				
Phs Duration (G+Y+Rc), s	9.0	21.5		15.6	5.9	24.6		15.6				
Change Period (Y+Rc), s	5.5	5.9		5.9	5.5	5.9		5.9				
Max Green Setting (Gmax), s	20.0	40.0		25.0	20.0	40.0		25.0				
Max Q Clear Time (g_c+I1), s	3.6	10.7		4.1	2.1	6.2		7.9				
Green Ext Time (p_c), s	0.2	4.6		0.8	0.0	5.3		1.7				

Intersection Summary

HCM 6th Ctrl Delay	13.5
HCM 6th LOS	B

Notes

User approved pedestrian interval to be less than phase max green.

Lanes, Volumes, Timings
3: Des Moines Memorial Dr & S 200th St

02/25/2021



Lane Group	EBL	EBT	EBR	WBL	WBT	WBR	NBL	NBT	NBR	SBL	SBT	SBR
Lane Configurations												
Traffic Volume (vph)	21	115	63	19	110	145	18	382	29	52	583	74
Future Volume (vph)	21	115	63	19	110	145	18	382	29	52	583	74
Ideal Flow (vphpl)	1900	1900	1900	1900	1900	1900	1900	1900	1900	1900	1900	1900
Storage Length (ft)	0		200	200		350	200		0	200		0
Storage Lanes	1		1	1		1	1		0	1		0
Taper Length (ft)	25			25			25			25		
Right Turn on Red			Yes			Yes			Yes			Yes
Link Speed (mph)		25			35			35			35	
Link Distance (ft)		533			538			421			545	
Travel Time (s)		14.5			10.5			8.2			10.6	
Confl. Peds. (#/hr)			1	1			1		1	1		1
Peak Hour Factor	0.82	0.82	0.82	0.82	0.82	0.82	0.82	0.82	0.82	0.82	0.82	0.82
Heavy Vehicles (%)	2%	2%	2%	5%	5%	5%	2%	2%	2%	3%	3%	3%
Shared Lane Traffic (%)												
Turn Type	pm+pt	NA		pm+pt	NA	Perm	pm+pt	NA		pm+pt	NA	
Protected Phases	3	8		7	4		5	2		1	6	
Permitted Phases	8			4		4	2			6		
Detector Phase	3	8		7	4	4	5	2		1	6	
Switch Phase												
Minimum Initial (s)	5.0	5.0		5.0	5.0	5.0	5.0	5.0		5.0	5.0	
Minimum Split (s)	10.0	30.0		10.0	31.0	31.0	10.0	32.0		10.0	30.0	
Total Split (s)	25.0	40.0		25.0	40.0	40.0	25.0	55.0		25.0	55.0	
Total Split (%)	17.2%	27.6%		17.2%	27.6%	27.6%	17.2%	37.9%		17.2%	37.9%	
Yellow Time (s)	4.0	4.0		4.0	4.0	4.0	4.0	4.0		4.0	4.0	
All-Red Time (s)	1.0	1.0		1.0	1.0	1.0	1.0	1.0		1.0	1.0	
Lost Time Adjust (s)	0.0	0.0		0.0	0.0	0.0	0.0	0.0		0.0	0.0	
Total Lost Time (s)	5.0	5.0		5.0	5.0	5.0	5.0	5.0		5.0	5.0	
Lead/Lag	Lead	Lag		Lead	Lag	Lag	Lead	Lag		Lead	Lag	
Lead-Lag Optimize?	Yes	Yes		Yes	Yes	Yes	Yes	Yes		Yes	Yes	
Recall Mode	None	None		None	None	None	None	None		None	None	

Intersection Summary

Area Type: Other

Cycle Length: 145

Actuated Cycle Length: 89.6

Natural Cycle: 95

Control Type: Semi Act-Uncoord

Splits and Phases: 3: Des Moines Memorial Dr & S 200th St

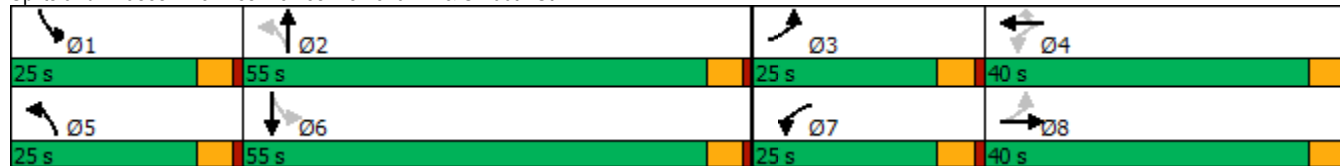

HCM 6th Signalized Intersection Summary
 3: Des Moines Memorial Dr & S 200th St

02/25/2021



Movement	EBL	EBT	EBR	WBL	WBT	WBR	NBL	NBT	NBR	SBL	SBT	SBR
Lane Configurations												
Traffic Volume (veh/h)	21	115	63	19	110	145	18	382	29	52	583	74
Future Volume (veh/h)	21	115	63	19	110	145	18	382	29	52	583	74
Initial Q (Qb), veh	0	0	0	0	0	0	0	0	0	0	0	0
Ped-Bike Adj(A_pbT)	1.00		1.00	1.00		1.00	1.00		1.00	1.00		1.00
Parking Bus, Adj	1.00	1.00	1.00	1.00	1.00	1.00	1.00	1.00	1.00	1.00	1.00	1.00
Work Zone On Approach		No			No			No			No	
Adj Sat Flow, veh/h/ln	1870	1870	1870	1826	1826	1826	1870	1870	1870	1856	1856	1856
Adj Flow Rate, veh/h	26	140	77	23	134	177	22	466	35	63	711	90
Peak Hour Factor	0.82	0.82	0.82	0.82	0.82	0.82	0.82	0.82	0.82	0.82	0.82	0.82
Percent Heavy Veh, %	2	2	2	5	5	5	2	2	2	3	3	3
Cap, veh/h	253	196	108	200	312	263	235	858	64	455	844	107
Arrive On Green	0.03	0.17	0.17	0.03	0.17	0.17	0.02	0.50	0.50	0.05	0.52	0.52
Sat Flow, veh/h	1781	1133	623	1739	1826	1543	1781	1718	129	1767	1614	204
Grp Volume(v), veh/h	26	0	217	23	134	177	22	0	501	63	0	801
Grp Sat Flow(s),veh/h/ln	1781	0	1756	1739	1826	1543	1781	0	1847	1767	0	1819
Q Serve(g_s), s	0.9	0.0	9.2	0.8	5.2	8.4	0.5	0.0	14.6	1.3	0.0	29.5
Cycle Q Clear(g_c), s	0.9	0.0	9.2	0.8	5.2	8.4	0.5	0.0	14.6	1.3	0.0	29.5
Prop In Lane	1.00		0.35	1.00		1.00	1.00		0.07	1.00		0.11
Lane Grp Cap(c), veh/h	253	0	304	200	312	263	235	0	923	455	0	951
V/C Ratio(X)	0.10	0.00	0.71	0.12	0.43	0.67	0.09	0.00	0.54	0.14	0.00	0.84
Avail Cap(c_a), veh/h	657	0	782	598	813	687	645	0	1175	820	0	1157
HCM Platoon Ratio	1.00	1.00	1.00	1.00	1.00	1.00	1.00	1.00	1.00	1.00	1.00	1.00
Upstream Filter(l)	1.00	0.00	1.00	1.00	1.00	1.00	1.00	0.00	1.00	1.00	0.00	1.00
Uniform Delay (d), s/veh	25.8	0.0	30.6	26.3	29.2	30.5	14.1	0.0	13.5	9.8	0.0	16.0
Incr Delay (d2), s/veh	0.2	0.0	6.5	0.3	2.0	6.2	0.2	0.0	1.1	0.1	0.0	6.2
Initial Q Delay(d3),s/veh	0.0	0.0	0.0	0.0	0.0	0.0	0.0	0.0	0.0	0.0	0.0	0.0
%ile BackOfQ(50%),veh/ln	0.4	0.0	4.4	0.3	2.3	3.5	0.2	0.0	5.6	0.5	0.0	12.1
Unsig. Movement Delay, s/veh												
LnGrp Delay(d),s/veh	26.0	0.0	37.1	26.5	31.2	36.7	14.2	0.0	14.6	10.0	0.0	22.2
LnGrp LOS	C	A	D	C	C	D	B	A	B	A	A	C
Approach Vol, veh/h		243			334			523			864	
Approach Delay, s/veh		35.9			33.8			14.5			21.3	
Approach LOS		D			C			B			C	
Timer - Assigned Phs	1	2	3	4	5	6	7	8				
Phs Duration (G+Y+Rc), s	8.7	44.3	7.2	18.4	6.9	46.1	7.0	18.6				
Change Period (Y+Rc), s	5.0	5.0	5.0	5.0	5.0	5.0	5.0	5.0				
Max Green Setting (Gmax), s	20.0	50.0	20.0	35.0	20.0	50.0	20.0	35.0				
Max Q Clear Time (g_c+I1), s	3.3	16.6	2.9	10.4	2.5	31.5	2.8	11.2				
Green Ext Time (p_c), s	0.1	6.9	0.0	2.8	0.0	9.6	0.0	2.4				
Intersection Summary												
HCM 6th Ctrl Delay			23.4									
HCM 6th LOS			C									

Lanes, Volumes, Timings
4: 26th Ave S & S 200th St

02/25/2021



Lane Group	EBL	EBT	EBR	WBL	WBT	WBR	NBL	NBT	NBR	SBL	SBT	SBR
Lane Configurations												
Traffic Volume (vph)	6	160	42	74	234	3	44	125	110	34	158	16
Future Volume (vph)	6	160	42	74	234	3	44	125	110	34	158	16
Ideal Flow (vphpl)	1900	1900	1900	1900	1900	1900	1900	1900	1900	1900	1900	1900
Grade (%)		9%			-9%			6%			-7%	
Storage Length (ft)	150		150	175		0	100		0	100		0
Storage Lanes	1		1	1		1	1		0	1		0
Taper Length (ft)	25			25			25			25		
Right Turn on Red			Yes			Yes			Yes			Yes
Link Speed (mph)		35			35			35			35	
Link Distance (ft)		707			875			1004			1058	
Travel Time (s)		13.8			17.0			19.6			20.6	
Confl. Peds. (#/hr)	1		2	2		1						
Peak Hour Factor	0.87	0.87	0.87	0.87	0.87	0.87	0.87	0.87	0.87	0.87	0.87	0.87
Heavy Vehicles (%)	0%	5%	11%	18%	9%	67%	10%	10%	8%	0%	5%	0%
Shared Lane Traffic (%)												
Turn Type	pm+pt	NA		pm+pt	NA	Perm	Perm	NA		Perm	NA	
Protected Phases	3	8		7	4			6			2	
Permitted Phases	8			4		4	6			2		
Detector Phase	3	8		7	4	4	6	6		2	2	
Switch Phase												
Minimum Initial (s)	5.0	10.0		5.0	10.0	10.0	10.0	10.0		10.0	10.0	
Minimum Split (s)	10.0	36.0		10.0	40.0	40.0	35.0	35.0		30.0	30.0	
Total Split (s)	30.0	55.0		30.0	55.0	55.0	55.0	55.0		55.0	55.0	
Total Split (%)	21.4%	39.3%		21.4%	39.3%	39.3%	39.3%	39.3%		39.3%	39.3%	
Yellow Time (s)	4.0	4.0		4.0	4.0	4.0	4.0	4.0		4.0	4.0	
All-Red Time (s)	1.0	1.0		1.0	1.0	1.0	1.0	1.0		1.0	1.0	
Lost Time Adjust (s)	0.0	0.0		0.0	0.0	0.0	0.0	0.0		0.0	0.0	
Total Lost Time (s)	5.0	5.0		5.0	5.0	5.0	5.0	5.0		5.0	5.0	
Lead/Lag	Lead	Lag		Lead	Lag	Lag						
Lead-Lag Optimize?	Yes	Yes		Yes	Yes	Yes						
Recall Mode	None	Min		None	Min	Min	None	None		None	None	

Intersection Summary

Area Type: Other

Cycle Length: 140

Actuated Cycle Length: 41

Natural Cycle: 85

Control Type: Actuated-Uncoordinated

Splits and Phases: 4: 26th Ave S & S 200th St

Ø2	Ø3	Ø4
55 s	30 s	55 s
Ø6	Ø7	Ø8
55 s	30 s	55 s

HCM 6th Signalized Intersection Summary
 4: 26th Ave S & S 200th St

02/25/2021



Movement	EBL	EBT	EBR	WBL	WBT	WBR	NBL	NBT	NBR	SBL	SBT	SBR
Lane Configurations												
Traffic Volume (veh/h)	6	160	42	74	234	3	44	125	110	34	158	16
Future Volume (veh/h)	6	160	42	74	234	3	44	125	110	34	158	16
Initial Q (Qb), veh	0	0	0	0	0	0	0	0	0	0	0	0
Ped-Bike Adj(A_pbT)	1.00		1.00	1.00		1.00	1.00		1.00	1.00		1.00
Parking Bus, Adj	1.00		1.00	1.00		1.00	1.00		1.00	1.00		1.00
Work Zone On Approach		No			No			No			No	
Adj Sat Flow, veh/h/ln	1423	1349	1260	1984	2119	1248	1540	1540	1569	2175	2100	2175
Adj Flow Rate, veh/h	7	184	48	85	269	3	51	144	126	39	182	18
Peak Hour Factor	0.87	0.87	0.87	0.87	0.87	0.87	0.87	0.87	0.87	0.87	0.87	0.87
Percent Heavy Veh, %	0	5	11	18	9	67	10	10	8	0	5	0
Cap, veh/h	406	550	140	574	721	359	402	398	323	415	954	93
Arrive On Green	0.01	0.27	0.27	0.08	0.34	0.34	0.26	0.26	0.26	0.26	0.26	0.26
Sat Flow, veh/h	1355	2022	514	1889	2119	1056	973	1534	1245	1290	3672	359
Grp Volume(v), veh/h	7	115	117	85	269	3	51	137	133	39	98	102
Grp Sat Flow(s),veh/h/ln	1355	1281	1255	1889	2119	1056	973	1463	1316	1290	1995	2036
Q Serve(g_s), s	0.1	2.8	2.9	1.2	3.7	0.1	1.7	2.9	3.2	1.0	1.5	1.5
Cycle Q Clear(g_c), s	0.1	2.8	2.9	1.2	3.7	0.1	3.2	2.9	3.2	4.2	1.5	1.5
Prop In Lane	1.00		0.41	1.00		1.00	1.00		0.95	1.00		0.18
Lane Grp Cap(c), veh/h	406	349	342	574	721	359	402	380	342	415	518	529
V/C Ratio(X)	0.02	0.33	0.34	0.15	0.37	0.01	0.13	0.36	0.39	0.09	0.19	0.19
Avail Cap(c_a), veh/h	1275	1668	1634	1657	2758	1375	1417	1904	1713	1759	2597	2650
HCM Platoon Ratio	1.00	1.00	1.00	1.00	1.00	1.00	1.00	1.00	1.00	1.00	1.00	1.00
Upstream Filter(l)	1.00	1.00	1.00	1.00	1.00	1.00	1.00	1.00	1.00	1.00	1.00	1.00
Uniform Delay (d), s/veh	10.0	11.2	11.2	8.6	9.6	8.4	12.3	11.6	11.7	13.4	11.1	11.1
Incr Delay (d2), s/veh	0.0	0.2	0.2	0.0	0.1	0.0	0.1	0.2	0.3	0.0	0.1	0.1
Initial Q Delay(d3),s/veh	0.0	0.0	0.0	0.0	0.0	0.0	0.0	0.0	0.0	0.0	0.0	0.0
%ile BackOfQ(50%),veh/ln	0.0	0.6	0.6	0.3	1.2	0.0	0.3	0.7	0.7	0.2	0.5	0.5
Unsig. Movement Delay, s/veh												
LnGrp Delay(d),s/veh	10.0	11.4	11.4	8.7	9.7	8.4	12.4	11.8	12.0	13.5	11.1	11.1
LnGrp LOS	A	B	B	A	A	A	B	B	B	B	B	B
Approach Vol, veh/h		239			357			321			239	
Approach Delay, s/veh		11.4			9.4			12.0			11.5	
Approach LOS		B			A			B			B	
Timer - Assigned Phs		2	3	4		6	7	8				
Phs Duration (G+Y+Rc), s		15.0	5.4	18.1		15.0	8.0	15.5				
Change Period (Y+Rc), s		5.0	5.0	5.0		5.0	5.0	5.0				
Max Green Setting (Gmax), s		50.0	25.0	50.0		50.0	25.0	50.0				
Max Q Clear Time (g_c+I1), s		6.2	2.1	5.7		5.2	3.2	4.9				
Green Ext Time (p_c), s		0.2	0.0	0.2		0.3	0.0	0.2				
Intersection Summary												
HCM 6th Ctrl Delay				11.0								
HCM 6th LOS				B								

Lanes, Volumes, Timings
1: Des Moines Memorial Dr & S 192nd St

02/25/2021



Lane Group	EBL	EBT	EBR	WBL	WBT	WBR	NBL	NBT	NBR	SBL	SBT	SBR
Lane Configurations												
Traffic Volume (vph)	20	28	38	44	30	11	18	581	24	10	807	14
Future Volume (vph)	20	28	38	44	30	11	18	581	24	10	807	14
Ideal Flow (vphpl)	1900	1900	1900	1900	1900	1900	1900	1900	1900	1900	1900	1900
Storage Length (ft)	150		0	200		0	150		0	150		0
Storage Lanes	1		0	1		0	1		0	1		0
Taper Length (ft)	25			25			25			25		
Right Turn on Red			Yes			Yes			Yes			Yes
Link Speed (mph)		35			25			35			35	
Link Distance (ft)		1090			1011			616			766	
Travel Time (s)		21.2			27.6			12.0			14.9	
Peak Hour Factor	0.94	0.94	0.94	0.94	0.94	0.94	0.94	0.94	0.94	0.94	0.94	0.94
Heavy Vehicles (%)	16%	7%	0%	8%	3%	18%	11%	1%	17%	90%	1%	23%
Shared Lane Traffic (%)												
Turn Type	pm+pt	NA		pm+pt	NA		Prot	NA		Prot	NA	
Protected Phases	3	8		7	4		5	2		1	6	
Permitted Phases	8			4								
Detector Phase	3	8		7	4		5	2		1	6	
Switch Phase												
Minimum Initial (s)	5.0	5.0		5.0	5.0		6.0	12.0		10.0	12.0	
Minimum Split (s)	10.0	27.0		10.0	10.0		12.0	22.0		16.0	22.0	
Total Split (s)	20.0	35.0		20.0	35.0		21.0	65.0		36.0	65.0	
Total Split (%)	12.8%	22.4%		12.8%	22.4%		13.5%	41.7%		23.1%	41.7%	
Yellow Time (s)	4.0	4.0		4.0	4.0		4.0	4.0		4.0	4.0	
All-Red Time (s)	1.0	1.0		1.0	1.0		2.0	1.0		2.0	1.0	
Lost Time Adjust (s)	0.0	0.0		0.0	0.0		0.0	0.0		0.0	0.0	
Total Lost Time (s)	5.0	5.0		5.0	5.0		6.0	5.0		6.0	5.0	
Lead/Lag	Lead	Lag		Lead	Lag		Lead	Lag		Lead	Lag	
Lead-Lag Optimize?	Yes	Yes		Yes	Yes		Yes	Yes		Yes	Yes	
Recall Mode	None	None		None	None		None	Min		None	Min	

Intersection Summary

Area Type: Other

Cycle Length: 156

Actuated Cycle Length: 78.3

Natural Cycle: 90

Control Type: Actuated-Uncoordinated

Splits and Phases: 1: Des Moines Memorial Dr & S 192nd St

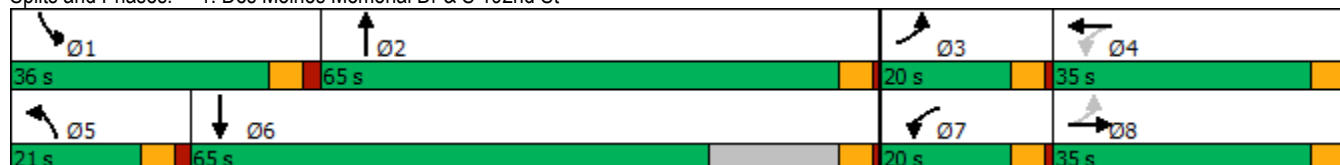

HCM 6th Signalized Intersection Summary

1: Des Moines Memorial Dr & S 192nd St

02/25/2021

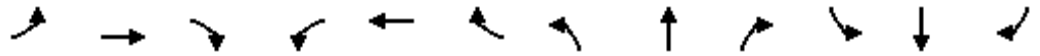

Movement	EBL	EBT	EBR	WBL	WBT	WBR	NBL	NBT	NBR	SBL	SBT	SBR
Lane Configurations												
Traffic Volume (veh/h)	20	28	38	44	30	11	18	581	24	10	807	14
Future Volume (veh/h)	20	28	38	44	30	11	18	581	24	10	807	14
Initial Q (Qb), veh	0	0	0	0	0	0	0	0	0	0	0	0
Ped-Bike Adj(A_pbT)	1.00		1.00	1.00		1.00	1.00		1.00	1.00		1.00
Parking Bus, Adj	1.00	1.00	1.00	1.00	1.00	1.00	1.00	1.00	1.00	1.00	1.00	1.00
Work Zone On Approach		No			No			No			No	
Adj Sat Flow, veh/h/ln	1663	1796	1900	1781	1856	1633	1737	1885	1648	566	1885	1559
Adj Flow Rate, veh/h	21	30	40	47	32	12	19	618	26	11	859	15
Peak Hour Factor	0.94	0.94	0.94	0.94	0.94	0.94	0.94	0.94	0.94	0.94	0.94	0.94
Percent Heavy Veh, %	16	7	0	8	3	18	11	1	17	90	1	23
Cap, veh/h	224	40	53	215	100	38	45	938	39	15	966	17
Arrive On Green	0.02	0.06	0.06	0.05	0.08	0.08	0.03	0.52	0.52	0.03	0.52	0.52
Sat Flow, veh/h	1584	698	931	1697	1286	482	1654	1796	76	539	1847	32
Grp Volume(v), veh/h	21	0	70	47	0	44	19	0	644	11	0	874
Grp Sat Flow(s),veh/h/ln	1584	0	1629	1697	0	1769	1654	0	1872	539	0	1879
Q Serve(g_s), s	0.7	0.0	2.6	1.5	0.0	1.4	0.7	0.0	15.1	1.2	0.0	25.1
Cycle Q Clear(g_c), s	0.7	0.0	2.6	1.5	0.0	1.4	0.7	0.0	15.1	1.2	0.0	25.1
Prop In Lane	1.00		0.57	1.00		0.27	1.00		0.04	1.00		0.02
Lane Grp Cap(c), veh/h	224	0	93	215	0	138	45	0	977	15	0	983
V/C Ratio(X)	0.09	0.00	0.75	0.22	0.00	0.32	0.42	0.00	0.66	0.73	0.00	0.89
Avail Cap(c_a), veh/h	578	0	809	559	0	878	411	0	1858	268	0	1866
HCM Platoon Ratio	1.00	1.00	1.00	1.00	1.00	1.00	1.00	1.00	1.00	1.00	1.00	1.00
Upstream Filter(l)	1.00	0.00	1.00	1.00	0.00	1.00	1.00	0.00	1.00	1.00	0.00	1.00
Uniform Delay (d), s/veh	25.8	0.0	28.1	25.1	0.0	26.4	28.9	0.0	10.5	29.1	0.0	12.8
Incr Delay (d2), s/veh	0.1	0.0	4.5	0.2	0.0	0.5	2.3	0.0	0.3	87.4	0.0	1.2
Initial Q Delay(d3),s/veh	0.0	0.0	0.0	0.0	0.0	0.0	0.0	0.0	0.0	0.0	0.0	0.0
%ile BackOfQ(50%),veh/ln	0.3	0.0	1.0	0.6	0.0	0.6	0.3	0.0	4.9	0.5	0.0	8.3
Unsig. Movement Delay, s/veh												
LnGrp Delay(d),s/veh	25.9	0.0	32.6	25.3	0.0	26.9	31.3	0.0	10.8	116.5	0.0	14.0
LnGrp LOS	C	A	C	C	A	C	C	A	B	F	A	B
Approach Vol, veh/h		91			91			663				885
Approach Delay, s/veh		31.0			26.0			11.4				15.3
Approach LOS		C			C			B				B
Timer - Assigned Phs	1	2	3	4	5	6	7	8				
Phs Duration (G+Y+Rc), s	7.7	36.6	6.5	9.7	7.6	36.6	7.7	8.5				
Change Period (Y+Rc), s	6.0	5.0	5.0	5.0	6.0	5.0	5.0	5.0				
Max Green Setting (Gmax), s	30.0	60.0	15.0	30.0	15.0	60.0	15.0	30.0				
Max Q Clear Time (g_c+I1), s	3.2	17.1	2.7	3.4	2.7	27.1	3.5	4.6				
Green Ext Time (p_c), s	0.0	2.9	0.0	0.1	0.0	4.6	0.0	0.2				
Intersection Summary												
HCM 6th Ctrl Delay			15.2									
HCM 6th LOS			B									

Lanes, Volumes, Timings
2: 1st Ave S (SR 509) & S 199th St

02/25/2021



Lane Group	EBL	EBT	EBR	WBL	WBT	WBR	NBL	NBT	NBR	SBL	SBT	SBR
Lane Configurations		↕	↗		↕		↗	↕		↗	↕↗	
Traffic Volume (vph)	52	77	9	51	62	74	6	319	55	236	557	27
Future Volume (vph)	52	77	9	51	62	74	6	319	55	236	557	27
Ideal Flow (vphpl)	1750	1750	1750	1750	1750	1750	1750	1750	1750	1750	1750	1750
Storage Length (ft)	0		0	0		0	100		0	150		150
Storage Lanes	0		1	0		0	1		0	1		1
Taper Length (ft)	25			25			25			25		
Right Turn on Red			Yes			Yes			Yes			Yes
Link Speed (mph)		25			25			35			35	
Link Distance (ft)		134			340			192			566	
Travel Time (s)		3.7			9.3			3.7			11.0	
Confl. Peds. (#/hr)	6					6	3					3
Peak Hour Factor	1.00	1.00	1.00	1.00	1.00	1.00	1.00	1.00	1.00	1.00	1.00	1.00
Heavy Vehicles (%)	0%	0%	0%	0%	0%	0%	0%	1%	0%	0%	1%	4%
Shared Lane Traffic (%)												
Turn Type	Perm	NA	Perm	Perm	NA		pm+pt	NA		pm+pt	NA	
Protected Phases		4			8		5	2		1		6
Permitted Phases	4		4	8			2			6		
Detector Phase	4	4	4	8	8		5	2		1		6
Switch Phase												
Minimum Initial (s)	7.0	7.0	7.0	7.0	7.0		5.0	10.0		5.0		10.0
Minimum Split (s)	35.9	35.9	35.9	35.9	35.9		10.5	26.9		10.5		26.9
Total Split (s)	35.9	35.9	35.9	35.9	35.9		25.5	55.9		25.5		55.9
Total Split (%)	30.6%	30.6%	30.6%	30.6%	30.6%		21.7%	47.7%		21.7%		47.7%
Yellow Time (s)	3.9	3.9	3.9	3.9	3.9		3.5	3.9		3.5		3.9
All-Red Time (s)	2.0	2.0	2.0	2.0	2.0		2.0	2.0		2.0		2.0
Lost Time Adjust (s)		0.0	0.0		0.0		0.0	0.0		0.0		0.0
Total Lost Time (s)		5.9	5.9		5.9		5.5	5.9		5.5		5.9
Lead/Lag							Lead	Lag		Lead		Lag
Lead-Lag Optimize?							Yes	Yes		Yes		Yes
Recall Mode	None	None	None	None	None		None	Min		None		Min

Intersection Summary

Area Type: Other

Cycle Length: 117.3

Actuated Cycle Length: 68.2

Natural Cycle: 75

Control Type: Actuated-Uncoordinated

Splits and Phases: 2: 1st Ave S (SR 509) & S 199th St



HCM 6th Signalized Intersection Summary
 2: 1st Ave S (SR 509) & S 199th St

02/25/2021



Movement	EBL	EBT	EBR	WBL	WBT	WBR	NBL	NBT	NBR	SBL	SBT	SBR
Lane Configurations		↕	↗		↕		↗	↖		↖	↕	↖
Traffic Volume (veh/h)	52	77	9	51	62	74	6	319	55	236	557	27
Future Volume (veh/h)	52	77	9	51	62	74	6	319	55	236	557	27
Initial Q (Qb), veh	0	0	0	0	0	0	0	0	0	0	0	0
Ped-Bike Adj(A_pbT)	0.99		0.99	0.99		0.99	1.00		1.00	1.00		1.00
Parking Bus, Adj	1.00	1.00	1.00	1.00	1.00	1.00	1.00	1.00	1.00	1.00	1.00	1.00
Work Zone On Approach		No			No			No			No	
Adj Sat Flow, veh/h/ln	1750	1750	1750	1750	1750	1750	1750	1736	1750	1750	1736	1695
Adj Flow Rate, veh/h	52	77	9	51	62	74	6	319	55	236	557	27
Peak Hour Factor	1.00	1.00	1.00	1.00	1.00	1.00	1.00	1.00	1.00	1.00	1.00	1.00
Percent Heavy Veh, %	0	0	0	0	0	0	0	1	0	0	1	4
Cap, veh/h	196	240	312	147	135	127	405	471	81	480	1431	69
Arrive On Green	0.21	0.21	0.21	0.21	0.21	0.21	0.01	0.33	0.33	0.13	0.45	0.45
Sat Flow, veh/h	464	1130	1470	275	639	598	1667	1442	249	1667	3202	155
Grp Volume(v), veh/h	129	0	9	187	0	0	6	0	374	236	287	297
Grp Sat Flow(s),veh/h/ln	1593	0	1470	1512	0	0	1667	0	1690	1667	1650	1708
Q Serve(g_s), s	0.0	0.0	0.3	2.1	0.0	0.0	0.1	0.0	9.9	4.3	6.0	6.1
Cycle Q Clear(g_c), s	3.3	0.0	0.3	5.6	0.0	0.0	0.1	0.0	9.9	4.3	6.0	6.1
Prop In Lane	0.40		1.00	0.27		0.40	1.00		0.15	1.00		0.09
Lane Grp Cap(c), veh/h	435	0	312	409	0	0	405	0	552	480	737	763
V/C Ratio(X)	0.30	0.00	0.03	0.46	0.00	0.00	0.01	0.00	0.68	0.49	0.39	0.39
Avail Cap(c_a), veh/h	967	0	849	944	0	0	1034	0	1627	908	1588	1644
HCM Platoon Ratio	1.00	1.00	1.00	1.00	1.00	1.00	1.00	1.00	1.00	1.00	1.00	1.00
Upstream Filter(l)	1.00	0.00	1.00	1.00	0.00	0.00	1.00	0.00	1.00	1.00	1.00	1.00
Uniform Delay (d), s/veh	17.4	0.0	16.2	18.3	0.0	0.0	11.5	0.0	15.1	9.6	9.6	9.6
Incr Delay (d2), s/veh	0.6	0.0	0.1	1.4	0.0	0.0	0.0	0.0	3.1	0.8	0.7	0.7
Initial Q Delay(d3),s/veh	0.0	0.0	0.0	0.0	0.0	0.0	0.0	0.0	0.0	0.0	0.0	0.0
%ile BackOfQ(50%),veh/ln	1.3	0.0	0.1	2.0	0.0	0.0	0.0	0.0	3.6	1.2	1.8	1.9
Unsig. Movement Delay, s/veh												
LnGrp Delay(d),s/veh	18.0	0.0	16.3	19.6	0.0	0.0	11.5	0.0	18.2	10.4	10.3	10.3
LnGrp LOS	B	A	B	B	A	A	B	A	B	B	B	B
Approach Vol, veh/h		138			187			380			820	
Approach Delay, s/veh		17.9			19.6			18.1			10.3	
Approach LOS		B			B			B			B	
Timer - Assigned Phs	1	2		4	5	6		8				
Phs Duration (G+Y+Rc), s	12.2	22.9		16.9	5.9	29.1		16.9				
Change Period (Y+Rc), s	5.5	5.9		5.9	5.5	5.9		5.9				
Max Green Setting (Gmax), s	20.0	50.0		30.0	20.0	50.0		30.0				
Max Q Clear Time (g_c+I1), s	6.3	11.9		5.3	2.1	8.1		7.6				
Green Ext Time (p_c), s	0.5	4.9		1.2	0.0	7.9		1.8				
Intersection Summary												
HCM 6th Ctrl Delay			14.1									
HCM 6th LOS			B									

Lanes, Volumes, Timings
 3: Des Moines Memorial Dr & S 200th St

02/25/2021



Lane Group	EBL	EBT	EBR	WBL	WBT	WBR	NBL	NBT	NBR	SBL	SBT	SBR
Lane Configurations												
Traffic Volume (vph)	28	194	146	70	162	234	14	354	30	136	740	11
Future Volume (vph)	28	194	146	70	162	234	14	354	30	136	740	11
Ideal Flow (vphpl)	1900	1900	1900	1900	1900	1900	1900	1900	1900	1900	1900	1900
Storage Length (ft)	0		200	200		350	200		0	200		0
Storage Lanes	1		1	1		1	1		0	1		0
Taper Length (ft)	25			25			25			25		
Right Turn on Red			Yes			Yes			Yes			Yes
Link Speed (mph)		25			35			35			35	
Link Distance (ft)		533			538			421			545	
Travel Time (s)		14.5			10.5			8.2			10.6	
Confl. Peds. (#/hr)			3	3								
Peak Hour Factor	0.98	0.98	0.98	0.98	0.98	0.98	0.98	0.98	0.98	0.98	0.98	0.98
Heavy Vehicles (%)	0%	1%	5%	2%	4%	4%	25%	2%	4%	7%	1%	0%
Shared Lane Traffic (%)												
Turn Type	pm+pt	NA		pm+pt	NA	Perm	pm+pt	NA		pm+pt	NA	
Protected Phases	3	8		7	4		5	2		1	6	
Permitted Phases	8			4		4	2			6		
Detector Phase	3	8		7	4	4	5	2		1	6	
Switch Phase												
Minimum Initial (s)	5.0	5.0		5.0	5.0	5.0	5.0	5.0		5.0	5.0	
Minimum Split (s)	10.0	30.0		10.0	31.0	31.0	10.0	32.0		10.0	30.0	
Total Split (s)	25.0	40.0		25.0	40.0	40.0	25.0	55.0		25.0	55.0	
Total Split (%)	17.2%	27.6%		17.2%	27.6%	27.6%	17.2%	37.9%		17.2%	37.9%	
Yellow Time (s)	4.0	4.0		4.0	4.0	4.0	4.0	4.0		4.0	4.0	
All-Red Time (s)	1.0	1.0		1.0	1.0	1.0	1.0	1.0		1.0	1.0	
Lost Time Adjust (s)	0.0	0.0		0.0	0.0	0.0	0.0	0.0		0.0	0.0	
Total Lost Time (s)	5.0	5.0		5.0	5.0	5.0	5.0	5.0		5.0	5.0	
Lead/Lag	Lead	Lag		Lead	Lag	Lag	Lead	Lag		Lead	Lag	
Lead-Lag Optimize?	Yes	Yes		Yes	Yes	Yes	Yes	Yes		Yes	Yes	
Recall Mode	None	None		None	None	None	None	None		None	None	

Intersection Summary

Area Type: Other

Cycle Length: 145

Actuated Cycle Length: 104

Natural Cycle: 85

Control Type: Actuated-Uncoordinated

Splits and Phases: 3: Des Moines Memorial Dr & S 200th St

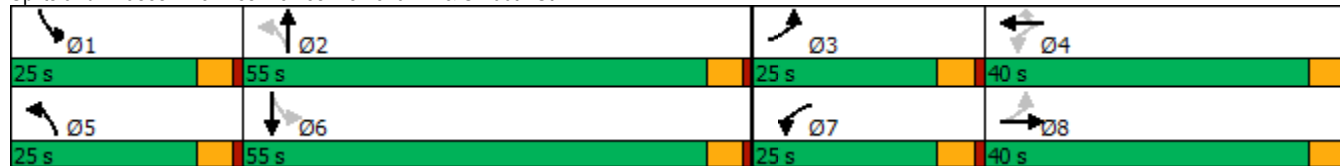

HCM 6th Signalized Intersection Summary
 3: Des Moines Memorial Dr & S 200th St

02/25/2021



Movement	EBL	EBT	EBR	WBL	WBT	WBR	NBL	NBT	NBR	SBL	SBT	SBR
Lane Configurations												
Traffic Volume (veh/h)	28	194	146	70	162	234	14	354	30	136	740	11
Future Volume (veh/h)	28	194	146	70	162	234	14	354	30	136	740	11
Initial Q (Qb), veh	0	0	0	0	0	0	0	0	0	0	0	0
Ped-Bike Adj(A_pbT)	1.00		0.99	1.00		0.99	1.00		1.00	1.00		1.00
Parking Bus, Adj	1.00	1.00	1.00	1.00	1.00	1.00	1.00	1.00	1.00	1.00	1.00	1.00
Work Zone On Approach		No			No			No			No	
Adj Sat Flow, veh/h/ln	1900	1885	1826	1870	1841	1841	1530	1870	1841	1796	1885	1900
Adj Flow Rate, veh/h	29	198	149	71	165	239	14	361	31	139	755	11
Peak Hour Factor	0.98	0.98	0.98	0.98	0.98	0.98	0.98	0.98	0.98	0.98	0.98	0.98
Percent Heavy Veh, %	0	1	5	2	4	4	25	2	4	7	1	0
Cap, veh/h	322	247	186	224	488	412	164	714	61	444	872	13
Arrive On Green	0.03	0.25	0.25	0.05	0.27	0.27	0.02	0.42	0.42	0.07	0.47	0.47
Sat Flow, veh/h	1810	996	749	1781	1841	1551	1457	1698	146	1711	1853	27
Grp Volume(v), veh/h	29	0	347	71	165	239	14	0	392	139	0	766
Grp Sat Flow(s),veh/h/ln	1810	0	1745	1781	1841	1551	1457	0	1844	1711	0	1880
Q Serve(g_s), s	1.1	0.0	17.0	2.7	6.6	12.2	0.5	0.0	14.3	4.0	0.0	33.2
Cycle Q Clear(g_c), s	1.1	0.0	17.0	2.7	6.6	12.2	0.5	0.0	14.3	4.0	0.0	33.2
Prop In Lane	1.00		0.43	1.00		1.00	1.00		0.08	1.00		0.01
Lane Grp Cap(c), veh/h	322	0	433	224	488	412	164	0	775	444	0	885
V/C Ratio(X)	0.09	0.00	0.80	0.32	0.34	0.58	0.09	0.00	0.51	0.31	0.00	0.87
Avail Cap(c_a), veh/h	667	0	669	533	706	595	459	0	1010	705	0	1030
HCM Platoon Ratio	1.00	1.00	1.00	1.00	1.00	1.00	1.00	1.00	1.00	1.00	1.00	1.00
Upstream Filter(l)	1.00	0.00	1.00	1.00	1.00	1.00	1.00	0.00	1.00	1.00	0.00	1.00
Uniform Delay (d), s/veh	24.4	0.0	32.2	25.4	27.1	29.1	19.2	0.0	19.5	13.8	0.0	21.6
Incr Delay (d2), s/veh	0.1	0.0	7.5	0.8	0.9	2.8	0.2	0.0	1.1	0.4	0.0	8.3
Initial Q Delay(d3),s/veh	0.0	0.0	0.0	0.0	0.0	0.0	0.0	0.0	0.0	0.0	0.0	0.0
%ile BackOfQ(50%),veh/ln	0.5	0.0	8.0	1.1	2.9	4.8	0.2	0.0	6.0	1.5	0.0	15.4
Unsig. Movement Delay, s/veh												
LnGrp Delay(d),s/veh	24.5	0.0	39.7	26.2	27.9	31.9	19.4	0.0	20.6	14.2	0.0	29.9
LnGrp LOS	C	A	D	C	C	C	B	A	C	B	A	C
Approach Vol, veh/h		376			475			406			905	
Approach Delay, s/veh		38.5			29.7			20.5			27.5	
Approach LOS		D			C			C			C	
Timer - Assigned Phs	1	2	3	4	5	6	7	8				
Phs Duration (G+Y+Rc), s	11.1	43.4	7.6	29.2	6.5	48.0	9.2	27.7				
Change Period (Y+Rc), s	5.0	5.0	5.0	5.0	5.0	5.0	5.0	5.0				
Max Green Setting (Gmax), s	20.0	50.0	20.0	35.0	20.0	50.0	20.0	35.0				
Max Q Clear Time (g_c+I1), s	6.0	16.3	3.1	14.2	2.5	35.2	4.7	19.0				
Green Ext Time (p_c), s	0.3	5.1	0.0	3.5	0.0	7.8	0.1	3.5				
Intersection Summary												
HCM 6th Ctrl Delay			28.6									
HCM 6th LOS			C									

Lanes, Volumes, Timings
4: 26th Ave S & S 200th St

02/25/2021



Lane Group	EBL	EBT	EBR	WBL	WBT	WBR	NBL	NBT	NBR	SBL	SBT	SBR
Lane Configurations												
Traffic Volume (vph)	16	287	86	85	371	7	104	135	54	31	281	11
Future Volume (vph)	16	287	86	85	371	7	104	135	54	31	281	11
Ideal Flow (vphpl)	1900	1900	1900	1900	1900	1900	1900	1900	1900	1900	1900	1900
Grade (%)		9%			-9%			6%			-7%	
Storage Length (ft)	150		150	175		0	100		0	100		0
Storage Lanes	1		1	1		1	1		0	1		0
Taper Length (ft)	25			25			25			25		
Right Turn on Red			Yes			Yes			Yes			Yes
Link Speed (mph)		35			35			35			35	
Link Distance (ft)		707			875			1004			1058	
Travel Time (s)		13.8			17.0			19.6			20.6	
Confl. Peds. (#/hr)	1		1	1		1			1	1		
Peak Hour Factor	0.94	0.94	0.94	0.94	0.94	0.94	0.94	0.94	0.94	0.94	0.94	0.94
Heavy Vehicles (%)	0%	1%	1%	13%	4%	29%	2%	8%	12%	0%	3%	0%
Shared Lane Traffic (%)												
Turn Type	pm+pt	NA		pm+pt	NA	Perm	Perm	NA		Perm	NA	
Protected Phases	3	8		7	4			6			2	
Permitted Phases	8			4		4	6			2		
Detector Phase	3	8		7	4	4	6	6		2	2	
Switch Phase												
Minimum Initial (s)	5.0	10.0		5.0	10.0	10.0	10.0	10.0		10.0	10.0	
Minimum Split (s)	10.0	36.0		10.0	40.0	40.0	35.0	35.0		30.0	30.0	
Total Split (s)	30.0	55.0		30.0	55.0	55.0	55.0	55.0		55.0	55.0	
Total Split (%)	21.4%	39.3%		21.4%	39.3%	39.3%	39.3%	39.3%		39.3%	39.3%	
Yellow Time (s)	4.0	4.0		4.0	4.0	4.0	4.0	4.0		4.0	4.0	
All-Red Time (s)	1.0	1.0		1.0	1.0	1.0	1.0	1.0		1.0	1.0	
Lost Time Adjust (s)	0.0	0.0		0.0	0.0	0.0	0.0	0.0		0.0	0.0	
Total Lost Time (s)	5.0	5.0		5.0	5.0	5.0	5.0	5.0		5.0	5.0	
Lead/Lag	Lead	Lag		Lead	Lag	Lag						
Lead-Lag Optimize?	Yes	Yes		Yes	Yes	Yes						
Recall Mode	None	Min		None	Min	Min	None	None		None	None	

Intersection Summary

Area Type: Other

Cycle Length: 140

Actuated Cycle Length: 47.7

Natural Cycle: 85

Control Type: Actuated-Uncoordinated

Splits and Phases: 4: 26th Ave S & S 200th St

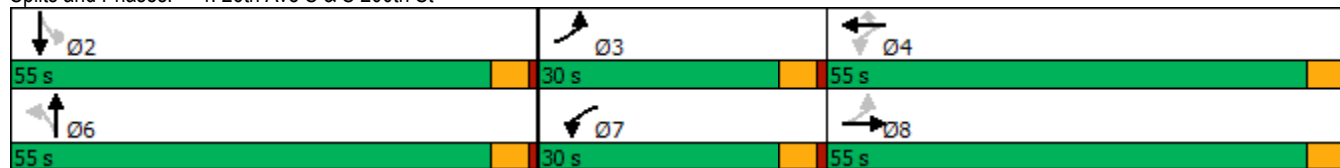

HCM 6th Signalized Intersection Summary

4: 26th Ave S & S 200th St

02/25/2021



Movement	EBL	EBT	EBR	WBL	WBT	WBR	NBL	NBT	NBR	SBL	SBT	SBR
Lane Configurations												
Traffic Volume (veh/h)	16	287	86	85	371	7	104	135	54	31	281	11
Future Volume (veh/h)	16	287	86	85	371	7	104	135	54	31	281	11
Initial Q (Qb), veh	0	0	0	0	0	0	0	0	0	0	0	0
Ped-Bike Adj(A_pbT)	1.00		1.00	1.00		1.00	1.00		1.00	1.00		1.00
Parking Bus, Adj	1.00	1.00	1.00	1.00	1.00	1.00	1.00	1.00	1.00	1.00	1.00	1.00
Work Zone On Approach		No			No			No			No	
Adj Sat Flow, veh/h/ln	1423	1408	1408	2059	2194	1819	1658	1569	1510	2175	2130	2175
Adj Flow Rate, veh/h	17	305	91	90	395	7	111	144	57	33	299	12
Peak Hour Factor	0.94	0.94	0.94	0.94	0.94	0.94	0.94	0.94	0.94	0.94	0.94	0.94
Percent Heavy Veh, %	0	1	1	13	4	29	2	8	12	0	3	0
Cap, veh/h	347	541	159	489	711	499	381	560	212	473	1051	42
Arrive On Green	0.02	0.27	0.27	0.08	0.32	0.32	0.26	0.26	0.26	0.26	0.26	0.26
Sat Flow, veh/h	1355	2040	598	1961	2194	1540	946	2113	802	1373	3966	159
Grp Volume(v), veh/h	17	198	198	90	395	7	111	100	101	33	152	159
Grp Sat Flow(s),veh/h/ln	1355	1338	1300	1961	2194	1540	946	1491	1424	1373	2024	2101
Q Serve(g_s), s	0.3	4.9	5.1	1.2	5.7	0.1	4.1	2.0	2.2	0.8	2.3	2.3
Cycle Q Clear(g_c), s	0.3	4.9	5.1	1.2	5.7	0.1	6.4	2.0	2.2	2.9	2.3	2.3
Prop In Lane	1.00		0.46	1.00		1.00	1.00		0.56	1.00		0.08
Lane Grp Cap(c), veh/h	347	355	345	489	711	499	381	395	377	473	536	557
V/C Ratio(X)	0.05	0.56	0.57	0.18	0.56	0.01	0.29	0.25	0.27	0.07	0.28	0.29
Avail Cap(c_a), veh/h	1198	1736	1687	1604	2847	1998	1358	1935	1848	1891	2626	2727
HCM Platoon Ratio	1.00	1.00	1.00	1.00	1.00	1.00	1.00	1.00	1.00	1.00	1.00	1.00
Upstream Filter(l)	1.00	1.00	1.00	1.00	1.00	1.00	1.00	1.00	1.00	1.00	1.00	1.00
Uniform Delay (d), s/veh	10.1	12.2	12.3	9.0	10.7	8.8	13.8	11.2	11.2	12.4	11.3	11.3
Incr Delay (d2), s/veh	0.0	0.5	0.6	0.1	0.3	0.0	0.2	0.1	0.1	0.0	0.1	0.1
Initial Q Delay(d3),s/veh	0.0	0.0	0.0	0.0	0.0	0.0	0.0	0.0	0.0	0.0	0.0	0.0
%ile BackOfQ(50%),veh/ln	0.1	1.2	1.2	0.4	2.0	0.0	0.7	0.5	0.5	0.2	0.8	0.8
Unsig. Movement Delay, s/veh												
LnGrp Delay(d),s/veh	10.1	12.7	12.8	9.1	11.0	8.8	14.0	11.3	11.3	12.4	11.4	11.4
LnGrp LOS	B	B	B	A	B	A	B	B	B	B	B	B
Approach Vol, veh/h		413			492			312			344	
Approach Delay, s/veh		12.7			10.6			12.3			11.5	
Approach LOS		B			B			B			B	
Timer - Assigned Phs		2	3	4		6	7	8				
Phs Duration (G+Y+Rc), s		15.2	5.8	17.5		15.2	8.1	15.2				
Change Period (Y+Rc), s		5.0	5.0	5.0		5.0	5.0	5.0				
Max Green Setting (Gmax), s		50.0	25.0	50.0		50.0	25.0	50.0				
Max Q Clear Time (g_c+I1), s		4.9	2.3	7.7		8.4	3.2	7.1				
Green Ext Time (p_c), s		0.3	0.0	0.4		0.3	0.0	0.4				
Intersection Summary												
HCM 6th Ctrl Delay				11.7								
HCM 6th LOS				B								

2023 With Project

Lanes, Volumes, Timings
1: Des Moines Memorial Dr & S 192nd St

07/14/2021



Lane Group	EBL	EBT	EBR	WBL	WBT	WBR	NBL	NBT	NBR	SBL	SBT	SBR
Lane Configurations												
Traffic Volume (vph)	15	31	30	11	31	17	103	1097	80	6	283	11
Future Volume (vph)	15	31	30	11	31	17	103	1097	80	6	283	11
Ideal Flow (vphpl)	1900	1900	1900	1900	1900	1900	1900	1900	1900	1900	1900	1900
Storage Length (ft)	150		0	200		0	150		0	150		0
Storage Lanes	1		0	1		0	1		0	1		0
Taper Length (ft)	25			25			25			25		
Right Turn on Red			Yes			Yes			Yes			Yes
Link Speed (mph)		35			25			35			35	
Link Distance (ft)		1090			1011			616			766	
Travel Time (s)		21.2			27.6			12.0			14.9	
Confl. Peds. (#/hr)			2	2					1			
Peak Hour Factor	0.92	0.92	0.92	0.92	0.92	0.92	0.92	0.92	0.92	0.92	0.92	0.92
Heavy Vehicles (%)	13%	23%	17%	18%	7%	53%	2%	2%	3%	17%	7%	9%
Shared Lane Traffic (%)												
Turn Type	pm+pt	NA		pm+pt	NA		Prot	NA		Prot	NA	
Protected Phases	3	8		7	4		5	2		1	6	
Permitted Phases	8			4								
Detector Phase	3	8		7	4		5	2		1	6	
Switch Phase												
Minimum Initial (s)	5.0	5.0		5.0	5.0		6.0	12.0		10.0	12.0	
Minimum Split (s)	10.0	27.0		10.0	10.0		12.0	22.0		16.0	22.0	
Total Split (s)	20.0	35.0		20.0	35.0		21.0	65.0		36.0	65.0	
Total Split (%)	12.8%	22.4%		12.8%	22.4%		13.5%	41.7%		23.1%	41.7%	
Yellow Time (s)	4.0	4.0		4.0	4.0		4.0	4.0		4.0	4.0	
All-Red Time (s)	1.0	1.0		1.0	1.0		2.0	1.0		2.0	1.0	
Lost Time Adjust (s)	0.0	0.0		0.0	0.0		0.0	0.0		0.0	0.0	
Total Lost Time (s)	5.0	5.0		5.0	5.0		6.0	5.0		6.0	5.0	
Lead/Lag	Lead	Lag		Lead	Lag		Lead	Lag		Lead	Lag	
Lead-Lag Optimize?	Yes	Yes		Yes	Yes		Yes	Yes		Yes	Yes	
Recall Mode	None	None		None	None		None	Min		None	Min	

Intersection Summary

Area Type: Other

Cycle Length: 156

Actuated Cycle Length: 85.5

Natural Cycle: 150

Control Type: Actuated-Uncoordinated

Splits and Phases: 1: Des Moines Memorial Dr & S 192nd St

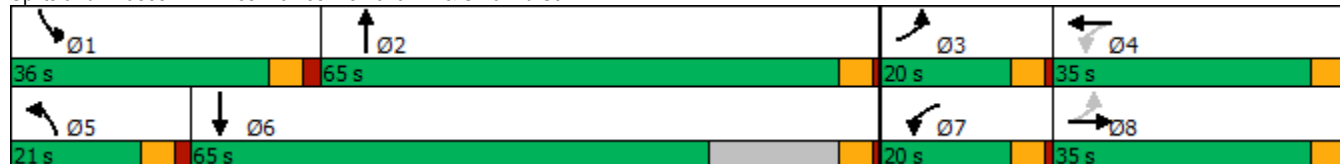

HCM 6th Signalized Intersection Summary

1: Des Moines Memorial Dr & S 192nd St

07/14/2021

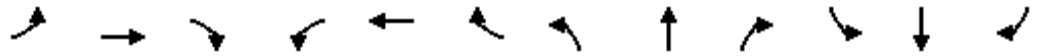

Movement	EBL	EBT	EBR	WBL	WBT	WBR	NBL	NBT	NBR	SBL	SBT	SBR
Lane Configurations												
Traffic Volume (veh/h)	15	31	30	11	31	17	103	1097	80	6	283	11
Future Volume (veh/h)	15	31	30	11	31	17	103	1097	80	6	283	11
Initial Q (Qb), veh	0	0	0	0	0	0	0	0	0	0	0	0
Ped-Bike Adj(A_pbT)	0.99		0.98	0.99		0.98	1.00		1.00	1.00		1.00
Parking Bus, Adj	1.00	1.00	1.00	1.00	1.00	1.00	1.00	1.00	1.00	1.00	1.00	1.00
Work Zone On Approach		No			No			No			No	
Adj Sat Flow, veh/h/ln	1707	1559	1648	1633	1796	1115	1870	1870	1856	1648	1796	1767
Adj Flow Rate, veh/h	16	34	33	12	34	18	112	1192	87	7	308	12
Peak Hour Factor	0.92	0.92	0.92	0.92	0.92	0.92	0.92	0.92	0.92	0.92	0.92	0.92
Percent Heavy Veh, %	13	23	17	18	7	53	2	2	3	17	7	9
Cap, veh/h	145	45	44	121	64	34	142	1155	84	28	1046	41
Arrive On Green	0.02	0.06	0.06	0.01	0.06	0.06	0.08	0.67	0.67	0.02	0.61	0.61
Sat Flow, veh/h	1626	720	699	1555	1098	581	1781	1722	126	1570	1717	67
Grp Volume(v), veh/h	16	0	67	12	0	52	112	0	1279	7	0	320
Grp Sat Flow(s),veh/h/ln	1626	0	1420	1555	0	1680	1781	0	1848	1570	0	1784
Q Serve(g_s), s	0.8	0.0	4.2	0.6	0.0	2.7	5.5	0.0	60.0	0.4	0.0	7.6
Cycle Q Clear(g_c), s	0.8	0.0	4.2	0.6	0.0	2.7	5.5	0.0	60.0	0.4	0.0	7.6
Prop In Lane	1.00		0.49	1.00		0.35	1.00		0.07	1.00		0.04
Lane Grp Cap(c), veh/h	145	0	88	121	0	98	142	0	1239	28	0	1087
V/C Ratio(X)	0.11	0.00	0.76	0.10	0.00	0.53	0.79	0.00	1.03	0.25	0.00	0.29
Avail Cap(c_a), veh/h	388	0	476	360	0	563	299	0	1239	526	0	1197
HCM Platoon Ratio	1.00	1.00	1.00	1.00	1.00	1.00	1.00	1.00	1.00	1.00	1.00	1.00
Upstream Filter(l)	1.00	0.00	1.00	1.00	0.00	1.00	1.00	0.00	1.00	1.00	0.00	1.00
Uniform Delay (d), s/veh	38.6	0.0	41.3	38.8	0.0	40.9	40.4	0.0	14.7	43.3	0.0	8.3
Incr Delay (d2), s/veh	0.1	0.0	4.9	0.1	0.0	1.7	3.7	0.0	34.2	9.6	0.0	0.1
Initial Q Delay(d3),s/veh	0.0	0.0	0.0	0.0	0.0	0.0	0.0	0.0	0.0	0.0	0.0	0.0
%ile BackOfQ(50%),veh/ln	0.3	0.0	1.5	0.3	0.0	1.2	2.5	0.0	30.9	0.2	0.0	2.6
Unsig. Movement Delay, s/veh												
LnGrp Delay(d),s/veh	38.7	0.0	46.2	39.0	0.0	42.6	44.1	0.0	48.9	53.0	0.0	8.4
LnGrp LOS	D	A	D	D	A	D	D	A	F	D	A	A
Approach Vol, veh/h		83			64			1391				327
Approach Delay, s/veh		44.7			41.9			48.5				9.3
Approach LOS		D			D			D				A
Timer - Assigned Phs	1	2	3	4	5	6	7	8				
Phs Duration (G+Y+Rc), s	7.6	65.0	6.6	10.2	13.1	59.5	6.3	10.6				
Change Period (Y+Rc), s	6.0	5.0	5.0	5.0	6.0	5.0	5.0	5.0				
Max Green Setting (Gmax), s	30.0	60.0	15.0	30.0	15.0	60.0	15.0	30.0				
Max Q Clear Time (g_c+I1), s	2.4	62.0	2.8	4.7	7.5	9.6	2.6	6.2				
Green Ext Time (p_c), s	0.0	0.0	0.0	0.1	0.1	1.2	0.0	0.2				
Intersection Summary												
HCM 6th Ctrl Delay			41.2									
HCM 6th LOS			D									

Lanes, Volumes, Timings
2: 1st Ave S (SR 509) & S 199th St

07/14/2021



Lane Group	EBL	EBT	EBR	WBL	WBT	WBR	NBL	NBT	NBR	SBL	SBT	SBR
Lane Configurations		↕	↗		↕		↗	↕		↗	↕↗	
Traffic Volume (vph)	26	21	4	26	53	96	10	349	72	113	190	21
Future Volume (vph)	26	21	4	26	53	96	10	349	72	113	190	21
Ideal Flow (vphpl)	1750	1750	1750	1750	1750	1750	1750	1750	1750	1750	1750	1750
Storage Length (ft)	0		0	0		0	100		0	150		150
Storage Lanes	0		1	0		0	1		0	1		1
Taper Length (ft)	25			25			25			25		
Right Turn on Red			Yes			Yes			Yes			Yes
Link Speed (mph)		25			25			35				35
Link Distance (ft)		134			340			192				566
Travel Time (s)		3.7			9.3			3.7				11.0
Confl. Peds. (#/hr)	3					3	2					2
Peak Hour Factor	1.00	1.00	1.00	1.00	1.00	1.00	1.00	1.00	1.00	1.00	1.00	1.00
Heavy Vehicles (%)	0%	0%	25%	0%	9%	17%	0%	1%	0%	6%	2%	0%
Shared Lane Traffic (%)												
Turn Type	Perm	NA	Perm	Perm	NA		pm+pt	NA		pm+pt	NA	
Protected Phases		4			8		5	2		1		6
Permitted Phases	4		4	8			2			6		
Detector Phase	4	4	4	8	8		5	2		1		6
Switch Phase												
Minimum Initial (s)	7.0	7.0	7.0	7.0	7.0		5.0	10.0		5.0		10.0
Minimum Split (s)	35.9	35.9	35.9	35.9	35.9		10.5	26.9		10.5		26.9
Total Split (s)	35.9	35.9	35.9	35.9	35.9		25.5	55.9		25.5		55.9
Total Split (%)	30.6%	30.6%	30.6%	30.6%	30.6%		21.7%	47.7%		21.7%		47.7%
Yellow Time (s)	3.9	3.9	3.9	3.9	3.9		3.5	3.9		3.5		3.9
All-Red Time (s)	2.0	2.0	2.0	2.0	2.0		2.0	2.0		2.0		2.0
Lost Time Adjust (s)		0.0	0.0		0.0		0.0	0.0		0.0		0.0
Total Lost Time (s)		5.9	5.9		5.9		5.5	5.9		5.5		5.9
Lead/Lag							Lead	Lag		Lead		Lag
Lead-Lag Optimize?							Yes	Yes		Yes		Yes
Recall Mode	None	None	None	None	None		None	Min		None		Min

Intersection Summary

Area Type: Other

Cycle Length: 117.3

Actuated Cycle Length: 63.9

Natural Cycle: 75

Control Type: Actuated-Uncoordinated

Splits and Phases: 2: 1st Ave S (SR 509) & S 199th St

Ø1	Ø2	Ø4
25.5 s	55.9 s	35.9 s
Ø5	Ø6	Ø8
25.5 s	55.9 s	35.9 s

HCM 6th Signalized Intersection Summary
 2: 1st Ave S (SR 509) & S 199th St

07/14/2021



Movement	EBL	EBT	EBR	WBL	WBT	WBR	NBL	NBT	NBR	SBL	SBT	SBR
Lane Configurations		↕	↗		↕		↗	↕		↗	↕↗	
Traffic Volume (veh/h)	26	21	4	26	53	96	10	349	72	113	190	21
Future Volume (veh/h)	26	21	4	26	53	96	10	349	72	113	190	21
Initial Q (Qb), veh	0	0	0	0	0	0	0	0	0	0	0	0
Ped-Bike Adj(A_pbT)	1.00		1.00	1.00		0.99	1.00		1.00	1.00		1.00
Parking Bus, Adj	1.00	1.00	1.00	1.00	1.00	1.00	1.00	1.00	1.00	1.00	1.00	1.00
Work Zone On Approach		No			No			No			No	
Adj Sat Flow, veh/h/ln	1750	1750	1409	1750	1627	1518	1750	1736	1750	1668	1723	1750
Adj Flow Rate, veh/h	26	21	4	26	53	96	10	349	72	113	190	21
Peak Hour Factor	1.00	1.00	1.00	1.00	1.00	1.00	1.00	1.00	1.00	1.00	1.00	1.00
Percent Heavy Veh, %	0	0	25	0	9	17	0	1	0	6	2	0
Cap, veh/h	251	167	231	108	103	153	574	516	106	413	1301	142
Arrive On Green	0.19	0.19	0.19	0.19	0.19	0.19	0.01	0.37	0.37	0.08	0.44	0.44
Sat Flow, veh/h	702	859	1188	119	529	788	1667	1396	288	1589	2975	325
Grp Volume(v), veh/h	47	0	4	175	0	0	10	0	421	113	104	107
Grp Sat Flow(s),veh/h/ln	1560	0	1188	1436	0	0	1667	0	1684	1589	1637	1663
Q Serve(g_s), s	0.0	0.0	0.1	1.3	0.0	0.0	0.2	0.0	10.2	2.0	1.8	1.9
Cycle Q Clear(g_c), s	1.1	0.0	0.1	5.3	0.0	0.0	0.2	0.0	10.2	2.0	1.8	1.9
Prop In Lane	0.55		1.00	0.15		0.55	1.00		0.17	1.00		0.20
Lane Grp Cap(c), veh/h	418	0	231	364	0	0	574	0	623	413	716	727
V/C Ratio(X)	0.11	0.00	0.02	0.48	0.00	0.00	0.02	0.00	0.68	0.27	0.14	0.15
Avail Cap(c_a), veh/h	993	0	733	958	0	0	1237	0	1730	938	1681	1709
HCM Platoon Ratio	1.00	1.00	1.00	1.00	1.00	1.00	1.00	1.00	1.00	1.00	1.00	1.00
Upstream Filter(l)	1.00	0.00	1.00	1.00	0.00	0.00	1.00	0.00	1.00	1.00	1.00	1.00
Uniform Delay (d), s/veh	16.2	0.0	15.9	17.9	0.0	0.0	9.3	0.0	12.9	9.2	8.2	8.2
Incr Delay (d2), s/veh	0.2	0.0	0.1	1.7	0.0	0.0	0.0	0.0	2.7	0.4	0.2	0.2
Initial Q Delay(d3),s/veh	0.0	0.0	0.0	0.0	0.0	0.0	0.0	0.0	0.0	0.0	0.0	0.0
%ile BackOfQ(50%),veh/ln	0.4	0.0	0.0	1.8	0.0	0.0	0.1	0.0	3.5	0.6	0.5	0.6
Unsig. Movement Delay, s/veh												
LnGrp Delay(d),s/veh	16.4	0.0	15.9	19.6	0.0	0.0	9.3	0.0	15.6	9.5	8.4	8.4
LnGrp LOS	B	A	B	B	A	A	A	A	B	A	A	A
Approach Vol, veh/h		51			175			431			324	
Approach Delay, s/veh		16.4			19.6			15.5			8.8	
Approach LOS		B			B			B			A	
Timer - Assigned Phs	1	2		4	5	6		8				
Phs Duration (G+Y+Rc), s	9.4	23.9		15.4	6.1	27.2		15.4				
Change Period (Y+Rc), s	5.5	5.9		5.9	5.5	5.9		5.9				
Max Green Setting (Gmax), s	20.0	50.0		30.0	20.0	50.0		30.0				
Max Q Clear Time (g_c+I1), s	4.0	12.2		3.1	2.2	3.9		7.3				
Green Ext Time (p_c), s	0.2	5.7		0.4	0.0	2.5		1.7				
Intersection Summary												
HCM 6th Ctrl Delay			14.1									
HCM 6th LOS			B									

Lanes, Volumes, Timings
 3: Des Moines Memorial Dr & S 200th St

07/14/2021



Lane Group	EBL	EBT	EBR	WBL	WBT	WBR	NBL	NBT	NBR	SBL	SBT	SBR
Lane Configurations												
Traffic Volume (vph)	29	144	33	19	133	298	35	958	62	77	265	7
Future Volume (vph)	29	144	33	19	133	298	35	958	62	77	265	7
Ideal Flow (vphpl)	1900	1900	1900	1900	1900	1900	1900	1900	1900	1900	1900	1900
Storage Length (ft)	0		200	200		350	200		0	200		0
Storage Lanes	1		1	1		1	1		0	1		0
Taper Length (ft)	25			25			25			25		
Right Turn on Red			Yes			Yes			Yes			Yes
Link Speed (mph)		25			35			35			35	
Link Distance (ft)		533			538			421			545	
Travel Time (s)		14.5			10.5			8.2			10.6	
Confl. Peds. (#/hr)	8		1	1		8	3					3
Peak Hour Factor	0.95	0.95	0.95	0.95	0.95	0.95	0.95	0.95	0.95	0.95	0.95	0.95
Heavy Vehicles (%)	3%	3%	3%	3%	3%	3%	1%	1%	1%	1%	1%	1%
Shared Lane Traffic (%)												
Turn Type	pm+pt	NA		pm+pt	NA	Perm	pm+pt	NA		pm+pt	NA	
Protected Phases	3	8		7	4		5	2		1	6	
Permitted Phases	8			4		4	2			6		
Detector Phase	3	8		7	4	4	5	2		1	6	
Switch Phase												
Minimum Initial (s)	5.0	5.0		5.0	5.0	5.0	5.0	5.0		5.0	5.0	
Minimum Split (s)	10.0	30.0		10.0	31.0	31.0	10.0	32.0		10.0	30.0	
Total Split (s)	25.0	40.0		25.0	40.0	40.0	25.0	55.0		25.0	55.0	
Total Split (%)	17.2%	27.6%		17.2%	27.6%	27.6%	17.2%	37.9%		17.2%	37.9%	
Yellow Time (s)	4.0	4.0		4.0	4.0	4.0	4.0	4.0		4.0	4.0	
All-Red Time (s)	1.0	1.0		1.0	1.0	1.0	1.0	1.0		1.0	1.0	
Lost Time Adjust (s)	0.0	0.0		0.0	0.0	0.0	0.0	0.0		0.0	0.0	
Total Lost Time (s)	5.0	5.0		5.0	5.0	5.0	5.0	5.0		5.0	5.0	
Lead/Lag	Lead	Lag		Lead	Lag	Lag	Lead	Lag		Lead	Lag	
Lead-Lag Optimize?	Yes	Yes		Yes	Yes	Yes	Yes	Yes		Yes	Yes	
Recall Mode	None	None		None	None	None	None	None		None	None	

Intersection Summary

Area Type: Other

Cycle Length: 145

Actuated Cycle Length: 95.1

Natural Cycle: 125

Control Type: Actuated-Uncoordinated

Splits and Phases: 3: Des Moines Memorial Dr & S 200th St



HCM 6th Signalized Intersection Summary

3: Des Moines Memorial Dr & S 200th St

07/14/2021

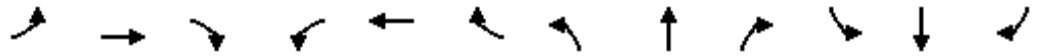

Movement	EBL	EBT	EBR	WBL	WBT	WBR	NBL	NBT	NBR	SBL	SBT	SBR
Lane Configurations												
Traffic Volume (veh/h)	29	144	33	19	133	298	35	958	62	77	265	7
Future Volume (veh/h)	29	144	33	19	133	298	35	958	62	77	265	7
Initial Q (Qb), veh	0	0	0	0	0	0	0	0	0	0	0	0
Ped-Bike Adj(A_pbT)	0.99		0.98	0.99		0.98	1.00		1.00	1.00		1.00
Parking Bus, Adj	1.00	1.00	1.00	1.00	1.00	1.00	1.00	1.00	1.00	1.00	1.00	1.00
Work Zone On Approach		No			No			No			No	
Adj Sat Flow, veh/h/ln	1856	1856	1856	1856	1856	1856	1885	1885	1885	1885	1885	1885
Adj Flow Rate, veh/h	31	152	35	20	140	314	37	1008	65	81	279	7
Peak Hour Factor	0.95	0.95	0.95	0.95	0.95	0.95	0.95	0.95	0.95	0.95	0.95	0.95
Percent Heavy Veh, %	3	3	3	3	3	3	1	1	1	1	1	1
Cap, veh/h	289	366	84	300	453	377	579	855	55	149	916	23
Arrive On Green	0.03	0.25	0.25	0.02	0.24	0.24	0.03	0.49	0.49	0.04	0.50	0.50
Sat Flow, veh/h	1767	1454	335	1767	1856	1547	1795	1751	113	1795	1831	46
Grp Volume(v), veh/h	31	0	187	20	140	314	37	0	1073	81	0	286
Grp Sat Flow(s),veh/h/ln	1767	0	1789	1767	1856	1547	1795	0	1864	1795	0	1877
Q Serve(g_s), s	1.3	0.0	9.0	0.9	6.3	19.7	1.0	0.0	50.0	2.3	0.0	9.2
Cycle Q Clear(g_c), s	1.3	0.0	9.0	0.9	6.3	19.7	1.0	0.0	50.0	2.3	0.0	9.2
Prop In Lane	1.00		0.19	1.00		1.00	1.00		0.06	1.00		0.02
Lane Grp Cap(c), veh/h	289	0	450	300	453	377	579	0	910	149	0	939
V/C Ratio(X)	0.11	0.00	0.42	0.07	0.31	0.83	0.06	0.00	1.18	0.54	0.00	0.30
Avail Cap(c_a), veh/h	584	0	611	608	634	529	873	0	910	421	0	939
HCM Platoon Ratio	1.00	1.00	1.00	1.00	1.00	1.00	1.00	1.00	1.00	1.00	1.00	1.00
Upstream Filter(l)	1.00	0.00	1.00	1.00	1.00	1.00	1.00	0.00	1.00	1.00	0.00	1.00
Uniform Delay (d), s/veh	27.8	0.0	32.0	28.3	31.7	36.7	12.4	0.0	26.2	23.9	0.0	15.1
Incr Delay (d2), s/veh	0.2	0.0	1.3	0.1	0.8	11.6	0.0	0.0	91.9	3.1	0.0	0.4
Initial Q Delay(d3),s/veh	0.0	0.0	0.0	0.0	0.0	0.0	0.0	0.0	0.0	0.0	0.0	0.0
%ile BackOfQ(50%),veh/ln	0.6	0.0	4.1	0.4	2.9	8.6	0.4	0.0	43.6	1.0	0.0	3.8
Unsig. Movement Delay, s/veh												
LnGrp Delay(d),s/veh	27.9	0.0	33.4	28.4	32.5	48.3	12.4	0.0	118.1	27.0	0.0	15.5
LnGrp LOS	C	A	C	C	C	D	B	A	F	C	A	B
Approach Vol, veh/h		218			474			1110				367
Approach Delay, s/veh		32.6			42.8			114.6				18.0
Approach LOS		C			D			F				B
Timer - Assigned Phs	1	2	3	4	5	6	7	8				
Phs Duration (G+Y+Rc), s	9.5	55.0	7.9	30.0	8.3	56.2	7.2	30.7				
Change Period (Y+Rc), s	5.0	5.0	5.0	5.0	5.0	5.0	5.0	5.0				
Max Green Setting (Gmax), s	20.0	50.0	20.0	35.0	20.0	50.0	20.0	35.0				
Max Q Clear Time (g_c+I1), s	4.3	52.0	3.3	21.7	3.0	11.2	2.9	11.0				
Green Ext Time (p_c), s	0.1	0.0	0.0	3.1	0.0	3.5	0.0	2.0				
Intersection Summary												
HCM 6th Ctrl Delay			74.3									
HCM 6th LOS			E									

Lanes, Volumes, Timings
4: 26th Ave S & S 200th St

07/14/2021



Lane Group	EBL	EBT	EBR	WBL	WBT	WBR	NBL	NBT	NBR	SBL	SBT	SBR
Lane Configurations												
Traffic Volume (vph)	32	230	33	51	382	7	78	153	40	5	68	8
Future Volume (vph)	32	230	33	51	382	7	78	153	40	5	68	8
Ideal Flow (vphpl)	1900	1900	1900	1900	1900	1900	1900	1900	1900	1900	1900	1900
Grade (%)		9%			-9%			6%			-7%	
Storage Length (ft)	150		150	175		0	100		0	100		0
Storage Lanes	1		1	1		1	1		0	1		0
Taper Length (ft)	25			25			25			25		
Right Turn on Red			Yes			Yes			Yes			Yes
Link Speed (mph)		35			35			35			35	
Link Distance (ft)		707			875			1004			1058	
Travel Time (s)		13.8			17.0			19.6			20.6	
Confl. Peds. (#/hr)	1					1						
Peak Hour Factor	0.96	0.96	0.96	0.96	0.96	0.96	0.96	0.96	0.96	0.96	0.96	0.96
Heavy Vehicles (%)	19%	11%	12%	24%	9%	29%	5%	7%	35%	0%	4%	0%
Shared Lane Traffic (%)												
Turn Type	pm+pt	NA		pm+pt	NA	Perm	Perm	NA		Perm	NA	
Protected Phases	3	8		7	4			6			2	
Permitted Phases	8			4		4	6			2		
Detector Phase	3	8		7	4	4	6	6		2	2	
Switch Phase												
Minimum Initial (s)	5.0	10.0		5.0	10.0	10.0	10.0	10.0		10.0	10.0	
Minimum Split (s)	10.0	36.0		10.0	40.0	40.0	35.0	35.0		30.0	30.0	
Total Split (s)	30.0	55.0		30.0	55.0	55.0	55.0	55.0		55.0	55.0	
Total Split (%)	21.4%	39.3%		21.4%	39.3%	39.3%	39.3%	39.3%		39.3%	39.3%	
Yellow Time (s)	4.0	4.0		4.0	4.0	4.0	4.0	4.0		4.0	4.0	
All-Red Time (s)	1.0	1.0		1.0	1.0	1.0	1.0	1.0		1.0	1.0	
Lost Time Adjust (s)	0.0	0.0		0.0	0.0	0.0	0.0	0.0		0.0	0.0	
Total Lost Time (s)	5.0	5.0		5.0	5.0	5.0	5.0	5.0		5.0	5.0	
Lead/Lag	Lead	Lag		Lead	Lag	Lag						
Lead-Lag Optimize?	Yes	Yes		Yes	Yes	Yes						
Recall Mode	None	Min		None	Min	Min	None	None		None	None	

Intersection Summary

Area Type: Other

Cycle Length: 140

Actuated Cycle Length: 41.9

Natural Cycle: 85

Control Type: Actuated-Uncoordinated

Splits and Phases: 4: 26th Ave S & S 200th St

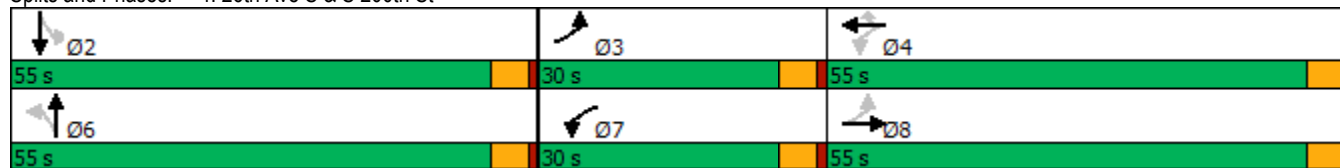

HCM 6th Signalized Intersection Summary

4: 26th Ave S & S 200th St

07/14/2021



Movement	EBL	EBT	EBR	WBL	WBT	WBR	NBL	NBT	NBR	SBL	SBT	SBR
Lane Configurations												
Traffic Volume (veh/h)	32	230	33	51	382	7	78	153	40	5	68	8
Future Volume (veh/h)	32	230	33	51	382	7	78	153	40	5	68	8
Initial Q (Qb), veh	0	0	0	0	0	0	0	0	0	0	0	0
Ped-Bike Adj(A_pbT)	1.00		1.00	1.00		1.00	1.00		1.00	1.00		1.00
Parking Bus, Adj	1.00		1.00	1.00		1.00	1.00		1.00	1.00		1.00
Work Zone On Approach		No			No			No			No	
Adj Sat Flow, veh/h/ln	1141	1260	1245	1894	2119	1819	1614	1584	1169	2175	2115	2175
Adj Flow Rate, veh/h	33	240	34	53	398	7	81	159	42	5	71	8
Peak Hour Factor	0.96	0.96	0.96	0.96	0.96	0.96	0.96	0.96	0.96	0.96	0.96	0.96
Percent Heavy Veh, %	19	11	12	24	9	29	5	7	35	0	4	0
Cap, veh/h	314	581	81	499	622	452	477	624	160	481	961	107
Arrive On Green	0.04	0.28	0.28	0.06	0.29	0.29	0.26	0.26	0.26	0.26	0.26	0.26
Sat Flow, veh/h	1087	2108	295	1804	2119	1540	1139	2371	609	1374	3648	404
Grp Volume(v), veh/h	33	135	139	53	398	7	81	99	102	5	39	40
Grp Sat Flow(s),veh/h/ln	1087	1197	1206	1804	2119	1540	1139	1505	1475	1374	2010	2042
Q Serve(g_s), s	0.8	3.4	3.5	0.7	6.1	0.1	2.1	1.9	2.0	0.1	0.5	0.6
Cycle Q Clear(g_c), s	0.8	3.4	3.5	0.7	6.1	0.1	2.7	1.9	2.0	2.1	0.5	0.6
Prop In Lane	1.00		0.24	1.00		1.00	1.00		0.41	1.00		0.20
Lane Grp Cap(c), veh/h	314	330	332	499	622	452	477	396	388	481	529	538
V/C Ratio(X)	0.11	0.41	0.42	0.11	0.64	0.02	0.17	0.25	0.26	0.01	0.07	0.08
Avail Cap(c_a), veh/h	1004	1613	1626	1612	2856	2075	1712	2029	1988	1971	2709	2753
HCM Platoon Ratio	1.00	1.00	1.00	1.00	1.00	1.00	1.00	1.00	1.00	1.00	1.00	1.00
Upstream Filter(l)	1.00	1.00	1.00	1.00	1.00	1.00	1.00	1.00	1.00	1.00	1.00	1.00
Uniform Delay (d), s/veh	9.4	11.0	11.0	8.7	11.4	9.3	11.3	10.8	10.8	11.7	10.3	10.3
Incr Delay (d2), s/veh	0.1	0.3	0.3	0.0	0.4	0.0	0.1	0.1	0.1	0.0	0.0	0.0
Initial Q Delay(d3),s/veh	0.0	0.0	0.0	0.0	0.0	0.0	0.0	0.0	0.0	0.0	0.0	0.0
%ile BackOfQ(50%),veh/ln	0.1	0.7	0.7	0.2	2.1	0.0	0.4	0.5	0.5	0.0	0.2	0.2
Unsig. Movement Delay, s/veh												
LnGrp Delay(d),s/veh	9.5	11.3	11.3	8.7	11.8	9.3	11.3	10.9	10.9	11.7	10.3	10.3
LnGrp LOS	A	B	B	A	B	A	B	B	B	B	B	B
Approach Vol, veh/h		307			458			282			84	
Approach Delay, s/veh		11.1			11.4			11.0			10.4	
Approach LOS		B			B			B			B	
Timer - Assigned Phs		2	3	4		6	7	8				
Phs Duration (G+Y+Rc), s		14.8	6.4	15.9		14.8	7.1	15.2				
Change Period (Y+Rc), s		5.0	5.0	5.0		5.0	5.0	5.0				
Max Green Setting (Gmax), s		50.0	25.0	50.0		50.0	25.0	50.0				
Max Q Clear Time (g_c+I1), s		4.1	2.8	8.1		4.7	2.7	5.5				
Green Ext Time (p_c), s		0.1	0.0	0.4		0.2	0.0	0.3				
Intersection Summary												
HCM 6th Ctrl Delay				11.2								
HCM 6th LOS				B								

Lanes, Volumes, Timings
 5: Des Moines Memorial Dr & Site Access

07/14/2021



Lane Group	WBL	WBR	NBT	NBR	SBL	SBT
Lane Configurations						
Traffic Volume (vph)	5	2	1268	17	5	344
Future Volume (vph)	5	2	1268	17	5	344
Ideal Flow (vphpl)	1900	1900	1900	1900	1900	1900
Link Speed (mph)	25		30			35
Link Distance (ft)	502		545			385
Travel Time (s)	13.7		12.4			7.5
Peak Hour Factor	0.92	0.92	0.92	0.92	0.92	0.92
Heavy Vehicles (%)	20%	50%	0%	0%	20%	0%
Shared Lane Traffic (%)						
Sign Control	Stop		Free			Free

Intersection Summary

Area Type: Other
 Control Type: Unsignalized

HCM 6th TWSC
5: Des Moines Memorial Dr & Site Access

07/14/2021

Intersection						
Int Delay, s/veh	0.2					
Movement	WBL	WBR	NBT	NBR	SBL	SBT
Lane Configurations	W	R	T	R	L	T
Traffic Vol, veh/h	5	2	1268	17	5	344
Future Vol, veh/h	5	2	1268	17	5	344
Conflicting Peds, #/hr	0	0	0	0	0	0
Sign Control	Stop	Stop	Free	Free	Free	Free
RT Channelized	-	None	-	None	-	None
Storage Length	0	-	-	-	-	-
Veh in Median Storage, #	0	-	0	-	-	0
Grade, %	0	-	0	-	-	0
Peak Hour Factor	92	92	92	92	92	92
Heavy Vehicles, %	20	50	0	0	20	0
Mvmt Flow	5	2	1378	18	5	374

Major/Minor	Minor1	Major1	Major2		
Conflicting Flow All	1771	1387	0	0	1396
Stage 1	1387	-	-	-	-
Stage 2	384	-	-	-	-
Critical Hdwy	6.6	6.7	-	-	4.3
Critical Hdwy Stg 1	5.6	-	-	-	-
Critical Hdwy Stg 2	5.6	-	-	-	-
Follow-up Hdwy	3.68	3.75	-	-	2.38
Pot Cap-1 Maneuver	82	137	-	-	437
Stage 1	212	-	-	-	-
Stage 2	651	-	-	-	-
Platoon blocked, %			-	-	-
Mov Cap-1 Maneuver	81	137	-	-	437
Mov Cap-2 Maneuver	81	-	-	-	-
Stage 1	212	-	-	-	-
Stage 2	642	-	-	-	-

Approach	WB	NB	SB
HCM Control Delay, s	47.6	0	0.2
HCM LOS	E		

Minor Lane/Major Mvmt	NBT	NBR	WBLn1	SBL	SBT
Capacity (veh/h)	-	-	92	437	-
HCM Lane V/C Ratio	-	-	0.083	0.012	-
HCM Control Delay (s)	-	-	47.6	13.3	0
HCM Lane LOS	-	-	E	B	A
HCM 95th %tile Q(veh)	-	-	0.3	0	-

Lanes, Volumes, Timings
 6: 12th PI S/West Site Access & S 200th St

07/14/2021



Lane Group	EBL	EBT	EBR	WBL	WBT	WBR	NBL	NBT	NBR	SBL	SBT	SBR
Lane Configurations												
Traffic Volume (vph)	6	276	1	0	443	3	6	0	6	1	0	1
Future Volume (vph)	6	276	1	0	443	3	6	0	6	1	0	1
Ideal Flow (vphpl)	1900	1900	1900	1900	1900	1900	1900	1900	1900	1900	1900	1900
Link Speed (mph)		35			35			25			25	
Link Distance (ft)		538			274			315			219	
Travel Time (s)		10.5			5.3			8.6			6.0	
Confl. Peds. (#/hr)	8		1	1		8						
Peak Hour Factor	0.78	0.78	0.78	0.78	0.78	0.78	0.78	0.78	0.78	0.78	0.78	0.78
Heavy Vehicles (%)	0%	10%	0%	0%	6%	33%	0%	0%	0%	0%	0%	0%
Shared Lane Traffic (%)												
Sign Control		Free			Free			Stop			Stop	

Intersection Summary

Area Type: Other
 Control Type: Unsignalized

HCM 6th TWSC
6: 12th PI S/West Site Access & S 200th St

07/14/2021

Intersection												
Int Delay, s/veh	0.4											
Movement	EBL	EBT	EBR	WBL	WBT	WBR	NBL	NBT	NBR	SBL	SBT	SBR
Lane Configurations		↕			↕			↕			↕	
Traffic Vol, veh/h	6	276	1	0	443	3	6	0	6	1	0	1
Future Vol, veh/h	6	276	1	0	443	3	6	0	6	1	0	1
Conflicting Peds, #/hr	8	0	1	1	0	8	0	0	0	0	0	0
Sign Control	Free	Free	Free	Free	Free	Free	Stop	Stop	Stop	Stop	Stop	Stop
RT Channelized	-	-	None	-	-	None	-	-	None	-	-	None
Storage Length	-	-	-	-	-	-	-	-	-	-	-	-
Veh in Median Storage, #	-	0	-	-	0	-	-	0	-	-	0	-
Grade, %	-	0	-	-	0	-	-	0	-	-	0	-
Peak Hour Factor	78	78	78	78	78	78	78	78	78	78	78	78
Heavy Vehicles, %	0	10	0	0	6	33	0	0	0	0	0	0
Mvmt Flow	8	354	1	0	568	4	8	0	8	1	0	1

Major/Minor	Major1			Major2			Minor1			Minor2		
Conflicting Flow All	580	0	0	356	0	0	943	952	356	953	950	578
Stage 1	-	-	-	-	-	-	372	372	-	578	578	-
Stage 2	-	-	-	-	-	-	571	580	-	375	372	-
Critical Hdwy	4.1	-	-	4.1	-	-	7.1	6.5	6.2	7.1	6.5	6.2
Critical Hdwy Stg 1	-	-	-	-	-	-	6.1	5.5	-	6.1	5.5	-
Critical Hdwy Stg 2	-	-	-	-	-	-	6.1	5.5	-	6.1	5.5	-
Follow-up Hdwy	2.2	-	-	2.2	-	-	3.5	4	3.3	3.5	4	3.3
Pot Cap-1 Maneuver	1004	-	-	1214	-	-	245	261	693	241	262	519
Stage 1	-	-	-	-	-	-	653	622	-	505	504	-
Stage 2	-	-	-	-	-	-	509	503	-	650	622	-
Platoon blocked, %	-	-	-	-	-	-	-	-	-	-	-	-
Mov Cap-1 Maneuver	996	-	-	1213	-	-	242	256	692	235	257	515
Mov Cap-2 Maneuver	-	-	-	-	-	-	242	256	-	235	257	-
Stage 1	-	-	-	-	-	-	646	615	-	496	500	-
Stage 2	-	-	-	-	-	-	508	499	-	636	615	-

Approach	EB	WB	NB	SB
HCM Control Delay, s	0.2	0	15.5	16.2
HCM LOS			C	C

Minor Lane/Major Mvmt	NBLn1	EBL	EBT	EBR	WBL	WBT	WBR	SBLn1
Capacity (veh/h)	359	996	-	-	1213	-	-	323
HCM Lane V/C Ratio	0.043	0.008	-	-	-	-	-	0.008
HCM Control Delay (s)	15.5	8.6	0	-	0	-	-	16.2
HCM Lane LOS	C	A	A	-	A	-	-	C
HCM 95th %tile Q(veh)	0.1	0	-	-	0	-	-	0

Lanes, Volumes, Timings
 7: S 200th St & East Site Access

07/14/2021

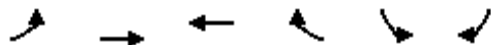

Lane Group	EBL	EBT	WBT	WBR	SBL	SBR
Lane Configurations						
Traffic Volume (vph)	1	289	443	17	4	1
Future Volume (vph)	1	289	443	17	4	1
Ideal Flow (vphpl)	1900	1900	1900	1900	1900	1900
Link Speed (mph)		30	35		25	
Link Distance (ft)		256	549		207	
Travel Time (s)		5.8	10.7		5.6	
Confl. Peds. (#/hr)	8			8		
Peak Hour Factor	0.92	0.92	0.92	0.92	0.92	0.92
Heavy Vehicles (%)	0%	0%	0%	6%	25%	0%
Shared Lane Traffic (%)						
Sign Control		Free	Free		Stop	

Intersection Summary

Area Type: Other

Control Type: Unsignalized

Intersection						
Int Delay, s/veh	0.1					
Movement	EBL	EBT	WBT	WBR	SBL	SBR
Lane Configurations		↕	↕		↕	
Traffic Vol, veh/h	1	289	443	17	4	1
Future Vol, veh/h	1	289	443	17	4	1
Conflicting Peds, #/hr	8	0	0	8	0	0
Sign Control	Free	Free	Free	Free	Stop	Stop
RT Channelized	-	None	-	None	-	None
Storage Length	-	-	-	-	0	-
Veh in Median Storage, #	-	0	0	-	0	-
Grade, %	-	0	0	-	0	-
Peak Hour Factor	92	92	92	92	92	92
Heavy Vehicles, %	0	0	0	6	25	0
Mvmt Flow	1	314	482	18	4	1

Major/Minor	Major1	Major2	Minor2		
Conflicting Flow All	508	0	-	0	815 499
Stage 1	-	-	-	-	499 -
Stage 2	-	-	-	-	316 -
Critical Hdwy	4.1	-	-	-	6.65 6.2
Critical Hdwy Stg 1	-	-	-	-	5.65 -
Critical Hdwy Stg 2	-	-	-	-	5.65 -
Follow-up Hdwy	2.2	-	-	-	3.725 3.3
Pot Cap-1 Maneuver	1067	-	-	-	317 576
Stage 1	-	-	-	-	565 -
Stage 2	-	-	-	-	690 -
Platoon blocked, %		-	-	-	
Mov Cap-1 Maneuver	1059	-	-	-	312 572
Mov Cap-2 Maneuver	-	-	-	-	312 -
Stage 1	-	-	-	-	560 -
Stage 2	-	-	-	-	684 -

Approach	EB	WB	SB
HCM Control Delay, s	0	0	15.7
HCM LOS			C

Minor Lane/Major Mvmt	EBL	EBT	WBT	WBR	SBLn1
Capacity (veh/h)	1059	-	-	-	343
HCM Lane V/C Ratio	0.001	-	-	-	0.016
HCM Control Delay (s)	8.4	0	-	-	15.7
HCM Lane LOS	A	A	-	-	C
HCM 95th %tile Q(veh)	0	-	-	-	0

Lanes, Volumes, Timings
 1: Des Moines Memorial Dr & S 192nd St

07/14/2021



Lane Group	EBL	EBT	EBR	WBL	WBT	WBR	NBL	NBT	NBR	SBL	SBT	SBR
Lane Configurations												
Traffic Volume (vph)	9	30	35	58	31	16	22	486	46	11	621	9
Future Volume (vph)	9	30	35	58	31	16	22	486	46	11	621	9
Ideal Flow (vphpl)	1900	1900	1900	1900	1900	1900	1900	1900	1900	1900	1900	1900
Storage Length (ft)	150		0	200		0	150		0	150		0
Storage Lanes	1		0	1		0	1		0	1		0
Taper Length (ft)	25			25			25			25		
Right Turn on Red			Yes			Yes			Yes			Yes
Link Speed (mph)		35			25			35			35	
Link Distance (ft)		1090			1011			616			766	
Travel Time (s)		21.2			27.6			12.0			14.9	
Confl. Peds. (#/hr)			2	2					1			
Peak Hour Factor	0.84	0.84	0.84	0.84	0.84	0.84	0.84	0.84	0.84	0.84	0.84	0.84
Heavy Vehicles (%)	22%	3%	11%	7%	23%	13%	9%	6%	15%	46%	2%	22%
Shared Lane Traffic (%)												
Turn Type	pm+pt	NA		pm+pt	NA		Prot	NA		Prot	NA	
Protected Phases	3	8		7	4		5	2		1	6	
Permitted Phases	8			4								
Detector Phase	3	8		7	4		5	2		1	6	
Switch Phase												
Minimum Initial (s)	5.0	5.0		5.0	5.0		6.0	12.0		10.0	12.0	
Minimum Split (s)	10.0	27.0		10.0	10.0		12.0	22.0		16.0	22.0	
Total Split (s)	20.0	35.0		20.0	35.0		21.0	65.0		36.0	65.0	
Total Split (%)	12.8%	22.4%		12.8%	22.4%		13.5%	41.7%		23.1%	41.7%	
Yellow Time (s)	4.0	4.0		4.0	4.0		4.0	4.0		4.0	4.0	
All-Red Time (s)	1.0	1.0		1.0	1.0		2.0	1.0		2.0	1.0	
Lost Time Adjust (s)	0.0	0.0		0.0	0.0		0.0	0.0		0.0	0.0	
Total Lost Time (s)	5.0	5.0		5.0	5.0		6.0	5.0		6.0	5.0	
Lead/Lag	Lead	Lag		Lead	Lag		Lead	Lag		Lead	Lag	
Lead-Lag Optimize?	Yes	Yes		Yes	Yes		Yes	Yes		Yes	Yes	
Recall Mode	None	None		None	None		None	Min		None	Min	

Intersection Summary

Area Type: Other

Cycle Length: 156

Actuated Cycle Length: 78.8

Natural Cycle: 90

Control Type: Actuated-Uncoordinated

Splits and Phases: 1: Des Moines Memorial Dr & S 192nd St

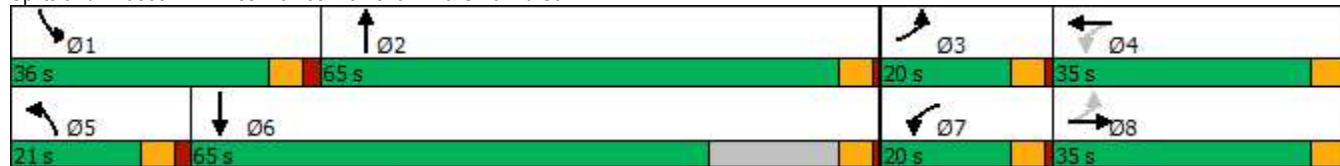

HCM 6th Signalized Intersection Summary

1: Des Moines Memorial Dr & S 192nd St

07/14/2021



Movement	EBL	EBT	EBR	WBL	WBT	WBR	NBL	NBT	NBR	SBL	SBT	SBR
Lane Configurations												
Traffic Volume (veh/h)	9	30	35	58	31	16	22	486	46	11	621	9
Future Volume (veh/h)	9	30	35	58	31	16	22	486	46	11	621	9
Initial Q (Qb), veh	0	0	0	0	0	0	0	0	0	0	0	0
Ped-Bike Adj(A_pbT)	0.99		0.99	0.99		0.99	1.00		1.00	1.00		1.00
Parking Bus, Adj	1.00	1.00	1.00	1.00	1.00	1.00	1.00	1.00	1.00	1.00	1.00	1.00
Work Zone On Approach		No			No			No			No	
Adj Sat Flow, veh/h/ln	1574	1856	1737	1796	1559	1707	1767	1811	1678	1218	1870	1574
Adj Flow Rate, veh/h	11	36	42	69	37	19	26	579	55	13	739	11
Peak Hour Factor	0.84	0.84	0.84	0.84	0.84	0.84	0.84	0.84	0.84	0.84	0.84	0.84
Percent Heavy Veh, %	22	3	11	7	23	13	9	6	15	46	2	22
Cap, veh/h	226	53	62	258	109	56	60	757	72	38	849	13
Arrive On Green	0.01	0.07	0.07	0.06	0.11	0.11	0.04	0.46	0.46	0.03	0.46	0.46
Sat Flow, veh/h	1499	776	905	1711	968	497	1682	1628	155	1160	1838	27
Grp Volume(v), veh/h	11	0	78	69	0	56	26	0	634	13	0	750
Grp Sat Flow(s),veh/h/ln	1499	0	1681	1711	0	1464	1682	0	1783	1160	0	1865
Q Serve(g_s), s	0.4	0.0	2.5	2.1	0.0	2.0	0.8	0.0	16.5	0.6	0.0	20.2
Cycle Q Clear(g_c), s	0.4	0.0	2.5	2.1	0.0	2.0	0.8	0.0	16.5	0.6	0.0	20.2
Prop In Lane	1.00		0.54	1.00		0.34	1.00		0.09	1.00		0.01
Lane Grp Cap(c), veh/h	226	0	114	258	0	165	60	0	829	38	0	862
V/C Ratio(X)	0.05	0.00	0.68	0.27	0.00	0.34	0.43	0.00	0.76	0.34	0.00	0.87
Avail Cap(c_a), veh/h	607	0	902	616	0	786	451	0	1914	623	0	2002
HCM Platoon Ratio	1.00	1.00	1.00	1.00	1.00	1.00	1.00	1.00	1.00	1.00	1.00	1.00
Upstream Filter(l)	1.00	0.00	1.00	1.00	0.00	1.00	1.00	0.00	1.00	1.00	0.00	1.00
Uniform Delay (d), s/veh	23.7	0.0	25.5	22.3	0.0	22.9	26.4	0.0	12.4	26.5	0.0	13.5
Incr Delay (d2), s/veh	0.0	0.0	2.7	0.2	0.0	0.4	1.8	0.0	0.6	11.0	0.0	1.1
Initial Q Delay(d3),s/veh	0.0	0.0	0.0	0.0	0.0	0.0	0.0	0.0	0.0	0.0	0.0	0.0
%ile BackOfQ(50%),veh/ln	0.1	0.0	1.0	0.8	0.0	0.7	0.3	0.0	5.3	0.3	0.0	6.8
Unsig. Movement Delay, s/veh												
LnGrp Delay(d),s/veh	23.8	0.0	28.1	22.5	0.0	23.3	28.2	0.0	13.0	37.5	0.0	14.6
LnGrp LOS	C	A	C	C	A	C	C	A	B	D	A	B
Approach Vol, veh/h		89			125			660				763
Approach Delay, s/veh		27.6			22.9			13.6				15.0
Approach LOS		C			C			B				B
Timer - Assigned Phs	1	2	3	4	5	6	7	8				
Phs Duration (G+Y+Rc), s	7.8	31.0	5.8	11.3	8.0	30.8	8.3	8.8				
Change Period (Y+Rc), s	6.0	5.0	5.0	5.0	6.0	5.0	5.0	5.0				
Max Green Setting (Gmax), s	30.0	60.0	15.0	30.0	15.0	60.0	15.0	30.0				
Max Q Clear Time (g_c+I1), s	2.6	18.5	2.4	4.0	2.8	22.2	4.1	4.5				
Green Ext Time (p_c), s	0.0	2.9	0.0	0.2	0.0	3.6	0.0	0.2				
Intersection Summary												
HCM 6th Ctrl Delay			15.7									
HCM 6th LOS			B									

Lanes, Volumes, Timings
2: 1st Ave S (SR 509) & S 199th St

07/14/2021



Lane Group	EBL	EBT	EBR	WBL	WBT	WBR	NBL	NBT	NBR	SBL	SBT	SBR
Lane Configurations		↕	↗		↕		↗	↕		↗	↕↗	
Traffic Volume (vph)	30	67	16	84	50	70	6	338	37	97	406	31
Future Volume (vph)	30	67	16	84	50	70	6	338	37	97	406	31
Ideal Flow (vphpl)	1750	1750	1750	1750	1750	1750	1750	1750	1750	1750	1750	1750
Storage Length (ft)	0		0	0		0	100		0	150		150
Storage Lanes	0		1	0		0	1		0	1		1
Taper Length (ft)	25			25			25			25		
Right Turn on Red			Yes			Yes			Yes			Yes
Link Speed (mph)		25			25			35				35
Link Distance (ft)		134			340			192				566
Travel Time (s)		3.7			9.3			3.7				11.0
Confl. Peds. (#/hr)	1		1	1		1	7		1	1		7
Peak Hour Factor	1.00	1.00	1.00	1.00	1.00	1.00	1.00	1.00	1.00	1.00	1.00	1.00
Heavy Vehicles (%)	0%	0%	0%	7%	0%	0%	0%	2%	0%	0%	2%	0%
Shared Lane Traffic (%)												
Turn Type	Perm	NA	Perm	Perm	NA		pm+pt	NA		pm+pt	NA	
Protected Phases		4			8		5	2		1		6
Permitted Phases	4		4	8			2			6		
Detector Phase	4	4	4	8	8		5	2		1		6
Switch Phase												
Minimum Initial (s)	7.0	7.0	7.0	7.0	7.0		5.0	10.0		5.0		10.0
Minimum Split (s)	35.9	35.9	35.9	35.9	35.9		10.5	26.9		10.5		26.9
Total Split (s)	30.9	30.9	30.9	30.9	30.9		25.5	45.9		25.5		45.9
Total Split (%)	30.2%	30.2%	30.2%	30.2%	30.2%		24.9%	44.9%		24.9%		44.9%
Yellow Time (s)	3.9	3.9	3.9	3.9	3.9		3.5	3.9		3.5		3.9
All-Red Time (s)	2.0	2.0	2.0	2.0	2.0		2.0	2.0		2.0		2.0
Lost Time Adjust (s)		0.0	0.0		0.0		0.0	0.0		0.0		0.0
Total Lost Time (s)		5.9	5.9		5.9		5.5	5.9		5.5		5.9
Lead/Lag							Lead	Lag		Lead		Lag
Lead-Lag Optimize?							Yes	Yes		Yes		Yes
Recall Mode	None	None	None	None	None		None	Min		None		Min

Intersection Summary

Area Type: Other

Cycle Length: 102.3

Actuated Cycle Length: 62.1

Natural Cycle: 75

Control Type: Actuated-Uncoordinated

Splits and Phases: 2: 1st Ave S (SR 509) & S 199th St

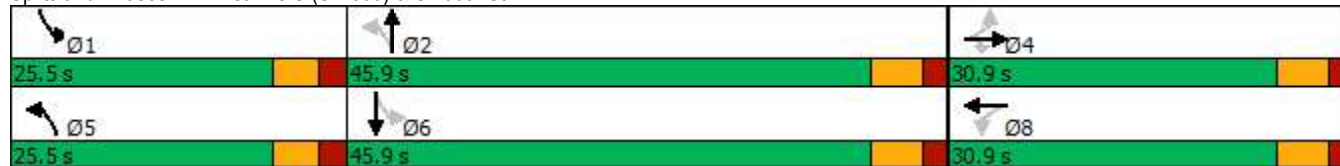

HCM 6th Signalized Intersection Summary
 2: 1st Ave S (SR 509) & S 199th St

07/14/2021



Movement	EBL	EBT	EBR	WBL	WBT	WBR	NBL	NBT	NBR	SBL	SBT	SBR
Lane Configurations		↕	↗		↕		↖	↗		↖	↕	↗
Traffic Volume (veh/h)	30	67	16	84	50	70	6	338	37	97	406	31
Future Volume (veh/h)	30	67	16	84	50	70	6	338	37	97	406	31
Initial Q (Qb), veh	0	0	0	0	0	0	0	0	0	0	0	0
Ped-Bike Adj(A_pbT)	1.00		1.00	1.00		1.00	0.99		0.99	1.00		0.99
Parking Bus, Adj	1.00	1.00	1.00	1.00	1.00	1.00	1.00	1.00	1.00	1.00	1.00	1.00
Work Zone On Approach		No			No			No			No	
Adj Sat Flow, veh/h/ln	1750	1750	1750	1654	1750	1750	1750	1723	1750	1750	1723	1750
Adj Flow Rate, veh/h	30	67	16	84	50	70	6	338	37	97	406	31
Peak Hour Factor	1.00	1.00	1.00	1.00	1.00	1.00	1.00	1.00	1.00	1.00	1.00	1.00
Percent Heavy Veh, %	0	0	0	7	0	0	0	2	0	0	2	0
Cap, veh/h	166	285	312	206	103	104	449	514	56	424	1252	95
Arrive On Green	0.21	0.21	0.21	0.21	0.21	0.21	0.01	0.34	0.34	0.08	0.41	0.41
Sat Flow, veh/h	305	1352	1481	455	488	492	1667	1524	167	1667	3080	234
Grp Volume(v), veh/h	97	0	16	204	0	0	6	0	375	97	215	222
Grp Sat Flow(s),veh/h/ln	1658	0	1481	1434	0	0	1667	0	1691	1667	1637	1678
Q Serve(g_s), s	0.0	0.0	0.4	3.8	0.0	0.0	0.1	0.0	8.7	1.7	4.1	4.2
Cycle Q Clear(g_c), s	2.1	0.0	0.4	6.0	0.0	0.0	0.1	0.0	8.7	1.7	4.1	4.2
Prop In Lane	0.31		1.00	0.41		0.34	1.00		0.10	1.00		0.14
Lane Grp Cap(c), veh/h	452	0	312	412	0	0	449	0	571	424	665	682
V/C Ratio(X)	0.21	0.00	0.05	0.49	0.00	0.00	0.01	0.00	0.66	0.23	0.32	0.33
Avail Cap(c_a), veh/h	956	0	802	880	0	0	1157	0	1464	1017	1417	1453
HCM Platoon Ratio	1.00	1.00	1.00	1.00	1.00	1.00	1.00	1.00	1.00	1.00	1.00	1.00
Upstream Filter(l)	1.00	0.00	1.00	1.00	0.00	0.00	1.00	0.00	1.00	1.00	1.00	1.00
Uniform Delay (d), s/veh	15.2	0.0	14.5	16.7	0.0	0.0	9.9	0.0	13.0	9.3	9.4	9.4
Incr Delay (d2), s/veh	0.4	0.0	0.1	1.6	0.0	0.0	0.0	0.0	2.7	0.3	0.6	0.6
Initial Q Delay(d3),s/veh	0.0	0.0	0.0	0.0	0.0	0.0	0.0	0.0	0.0	0.0	0.0	0.0
%ile BackOfQ(50%),veh/ln	0.8	0.0	0.1	1.9	0.0	0.0	0.0	0.0	3.0	0.5	1.2	1.3
Unsig. Movement Delay, s/veh												
LnGrp Delay(d),s/veh	15.6	0.0	14.7	18.2	0.0	0.0	10.0	0.0	15.8	9.6	10.0	10.0
LnGrp LOS	B	A	B	B	A	A	A	A	B	A	A	A
Approach Vol, veh/h		113			204			381			534	
Approach Delay, s/veh		15.5			18.2			15.7			9.9	
Approach LOS		B			B			B			A	
Timer - Assigned Phs	1	2		4	5	6		8				
Phs Duration (G+Y+Rc), s	9.1	21.5		15.6	5.9	24.7		15.6				
Change Period (Y+Rc), s	5.5	5.9		5.9	5.5	5.9		5.9				
Max Green Setting (Gmax), s	20.0	40.0		25.0	20.0	40.0		25.0				
Max Q Clear Time (g_c+I1), s	3.7	10.7		4.1	2.1	6.2		8.0				
Green Ext Time (p_c), s	0.2	4.6		0.8	0.0	5.3		1.7				

Intersection Summary

HCM 6th Ctrl Delay	13.6
HCM 6th LOS	B

Notes

User approved pedestrian interval to be less than phase max green.

Lanes, Volumes, Timings
 3: Des Moines Memorial Dr & S 200th St

07/14/2021



Lane Group	EBL	EBT	EBR	WBL	WBT	WBR	NBL	NBT	NBR	SBL	SBT	SBR
Lane Configurations												
Traffic Volume (vph)	21	116	63	19	111	152	18	382	30	60	584	74
Future Volume (vph)	21	116	63	19	111	152	18	382	30	60	584	74
Ideal Flow (vphpl)	1900	1900	1900	1900	1900	1900	1900	1900	1900	1900	1900	1900
Storage Length (ft)	0		200	200		350	200		0	200		0
Storage Lanes	1		1	1		1	1		0	1		0
Taper Length (ft)	25			25			25			25		
Right Turn on Red			Yes			Yes			Yes			Yes
Link Speed (mph)		25			35			35			35	
Link Distance (ft)		533			538			421			545	
Travel Time (s)		14.5			10.5			8.2			10.6	
Confl. Peds. (#/hr)			1	1			1		1	1		1
Peak Hour Factor	0.82	0.82	0.82	0.82	0.82	0.82	0.82	0.82	0.82	0.82	0.82	0.82
Heavy Vehicles (%)	2%	2%	2%	5%	5%	5%	2%	2%	2%	3%	3%	3%
Shared Lane Traffic (%)												
Turn Type	pm+pt	NA		pm+pt	NA	Perm	pm+pt	NA		pm+pt	NA	
Protected Phases	3	8		7	4		5	2		1	6	
Permitted Phases	8			4		4	2			6		
Detector Phase	3	8		7	4	4	5	2		1	6	
Switch Phase												
Minimum Initial (s)	5.0	5.0		5.0	5.0	5.0	5.0	5.0		5.0	5.0	
Minimum Split (s)	10.0	30.0		10.0	31.0	31.0	10.0	32.0		10.0	30.0	
Total Split (s)	25.0	40.0		25.0	40.0	40.0	25.0	55.0		25.0	55.0	
Total Split (%)	17.2%	27.6%		17.2%	27.6%	27.6%	17.2%	37.9%		17.2%	37.9%	
Yellow Time (s)	4.0	4.0		4.0	4.0	4.0	4.0	4.0		4.0	4.0	
All-Red Time (s)	1.0	1.0		1.0	1.0	1.0	1.0	1.0		1.0	1.0	
Lost Time Adjust (s)	0.0	0.0		0.0	0.0	0.0	0.0	0.0		0.0	0.0	
Total Lost Time (s)	5.0	5.0		5.0	5.0	5.0	5.0	5.0		5.0	5.0	
Lead/Lag	Lead	Lag		Lead	Lag	Lag	Lead	Lag		Lead	Lag	
Lead-Lag Optimize?	Yes	Yes		Yes	Yes	Yes	Yes	Yes		Yes	Yes	
Recall Mode	None	None		None	None	None	None	None		None	None	

Intersection Summary

Area Type: Other

Cycle Length: 145

Actuated Cycle Length: 90

Natural Cycle: 95

Control Type: Semi Act-Uncoord

Splits and Phases: 3: Des Moines Memorial Dr & S 200th St



HCM 6th Signalized Intersection Summary
 3: Des Moines Memorial Dr & S 200th St

07/14/2021

Movement	EBL	EBT	EBR	WBL	WBT	WBR	NBL	NBT	NBR	SBL	SBT	SBR
Lane Configurations												
Traffic Volume (veh/h)	21	116	63	19	111	152	18	382	30	60	584	74
Future Volume (veh/h)	21	116	63	19	111	152	18	382	30	60	584	74
Initial Q (Qb), veh	0	0	0	0	0	0	0	0	0	0	0	0
Ped-Bike Adj(A_pbT)	1.00		1.00	1.00		1.00	1.00		1.00	1.00		1.00
Parking Bus, Adj	1.00	1.00	1.00	1.00	1.00	1.00	1.00	1.00	1.00	1.00	1.00	1.00
Work Zone On Approach		No			No			No			No	
Adj Sat Flow, veh/h/ln	1870	1870	1870	1826	1826	1826	1870	1870	1870	1856	1856	1856
Adj Flow Rate, veh/h	26	141	77	23	135	185	22	466	37	73	712	90
Peak Hour Factor	0.82	0.82	0.82	0.82	0.82	0.82	0.82	0.82	0.82	0.82	0.82	0.82
Percent Heavy Veh, %	2	2	2	5	5	5	2	2	2	3	3	3
Cap, veh/h	255	201	110	203	319	270	232	847	67	452	842	106
Arrive On Green	0.03	0.18	0.18	0.03	0.17	0.17	0.02	0.50	0.50	0.05	0.52	0.52
Sat Flow, veh/h	1781	1136	620	1739	1826	1543	1781	1710	136	1767	1614	204
Grp Volume(v), veh/h	26	0	218	23	135	185	22	0	503	73	0	802
Grp Sat Flow(s),veh/h/ln	1781	0	1757	1739	1826	1543	1781	0	1846	1767	0	1819
Q Serve(g_s), s	0.9	0.0	9.3	0.9	5.2	8.9	0.5	0.0	15.0	1.6	0.0	30.0
Cycle Q Clear(g_c), s	0.9	0.0	9.3	0.9	5.2	8.9	0.5	0.0	15.0	1.6	0.0	30.0
Prop In Lane	1.00		0.35	1.00		1.00	1.00		0.07	1.00		0.11
Lane Grp Cap(c), veh/h	255	0	311	203	319	270	232	0	914	452	0	949
V/C Ratio(X)	0.10	0.00	0.70	0.11	0.42	0.69	0.09	0.00	0.55	0.16	0.00	0.85
Avail Cap(c_a), veh/h	655	0	775	598	805	680	637	0	1163	808	0	1146
HCM Platoon Ratio	1.00	1.00	1.00	1.00	1.00	1.00	1.00	1.00	1.00	1.00	1.00	1.00
Upstream Filter(l)	1.00	0.00	1.00	1.00	1.00	1.00	1.00	0.00	1.00	1.00	0.00	1.00
Uniform Delay (d), s/veh	25.8	0.0	30.7	26.3	29.2	30.7	14.3	0.0	13.9	10.1	0.0	16.2
Incr Delay (d2), s/veh	0.2	0.0	6.0	0.2	1.9	6.5	0.2	0.0	1.1	0.2	0.0	6.4
Initial Q Delay(d3),s/veh	0.0	0.0	0.0	0.0	0.0	0.0	0.0	0.0	0.0	0.0	0.0	0.0
%ile BackOfQ(50%),veh/ln	0.4	0.0	4.4	0.4	2.4	3.7	0.2	0.0	5.8	0.5	0.0	12.4
Unsig. Movement Delay, s/veh												
LnGrp Delay(d),s/veh	26.0	0.0	36.7	26.5	31.1	37.2	14.5	0.0	15.0	10.2	0.0	22.7
LnGrp LOS	C	A	D	C	C	D	B	A	B	B	A	C
Approach Vol, veh/h		244			343			525			875	
Approach Delay, s/veh		35.5			34.1			15.0			21.6	
Approach LOS		D			C			B			C	
Timer - Assigned Phs	1	2	3	4	5	6	7	8				
Phs Duration (G+Y+Rc), s	9.0	44.3	7.2	18.9	6.9	46.4	7.0	19.1				
Change Period (Y+Rc), s	5.0	5.0	5.0	5.0	5.0	5.0	5.0	5.0				
Max Green Setting (Gmax), s	20.0	50.0	20.0	35.0	20.0	50.0	20.0	35.0				
Max Q Clear Time (g_c+I1), s	3.6	17.0	2.9	10.9	2.5	32.0	2.9	11.3				
Green Ext Time (p_c), s	0.1	6.9	0.0	2.8	0.0	9.4	0.0	2.4				
Intersection Summary												
HCM 6th Ctrl Delay			23.7									
HCM 6th LOS			C									

Lanes, Volumes, Timings
4: 26th Ave S & S 200th St

07/14/2021



Lane Group	EBL	EBT	EBR	WBL	WBT	WBR	NBL	NBT	NBR	SBL	SBT	SBR
Lane Configurations												
Traffic Volume (vph)	6	173	42	74	245	3	44	125	110	34	158	16
Future Volume (vph)	6	173	42	74	245	3	44	125	110	34	158	16
Ideal Flow (vphpl)	1900	1900	1900	1900	1900	1900	1900	1900	1900	1900	1900	1900
Grade (%)		9%			-9%			6%			-7%	
Storage Length (ft)	150		150	175		0	100		0	100		0
Storage Lanes	1		1	1		1	1		0	1		0
Taper Length (ft)	25			25			25			25		
Right Turn on Red			Yes			Yes			Yes			Yes
Link Speed (mph)		35			35			35			35	
Link Distance (ft)		707			875			1004			1058	
Travel Time (s)		13.8			17.0			19.6			20.6	
Confl. Peds. (#/hr)	1		2	2		1						
Peak Hour Factor	0.87	0.87	0.87	0.87	0.87	0.87	0.87	0.87	0.87	0.87	0.87	0.87
Heavy Vehicles (%)	0%	7%	12%	19%	11%	67%	9%	10%	7%	0%	4%	0%
Shared Lane Traffic (%)												
Turn Type	pm+pt	NA		pm+pt	NA	Perm	Perm	NA		Perm	NA	
Protected Phases	3	8		7	4			6			2	
Permitted Phases	8			4		4	6			2		
Detector Phase	3	8		7	4	4	6	6		2	2	
Switch Phase												
Minimum Initial (s)	5.0	10.0		5.0	10.0	10.0	10.0	10.0		10.0	10.0	
Minimum Split (s)	10.0	36.0		10.0	40.0	40.0	35.0	35.0		30.0	30.0	
Total Split (s)	30.0	55.0		30.0	55.0	55.0	55.0	55.0		55.0	55.0	
Total Split (%)	21.4%	39.3%		21.4%	39.3%	39.3%	39.3%	39.3%		39.3%	39.3%	
Yellow Time (s)	4.0	4.0		4.0	4.0	4.0	4.0	4.0		4.0	4.0	
All-Red Time (s)	1.0	1.0		1.0	1.0	1.0	1.0	1.0		1.0	1.0	
Lost Time Adjust (s)	0.0	0.0		0.0	0.0	0.0	0.0	0.0		0.0	0.0	
Total Lost Time (s)	5.0	5.0		5.0	5.0	5.0	5.0	5.0		5.0	5.0	
Lead/Lag	Lead	Lag		Lead	Lag	Lag						
Lead-Lag Optimize?	Yes	Yes		Yes	Yes	Yes						
Recall Mode	None	Min		None	Min	Min	None	None		None	None	

Intersection Summary

Area Type: Other

Cycle Length: 140

Actuated Cycle Length: 41

Natural Cycle: 85

Control Type: Actuated-Uncoordinated

Splits and Phases: 4: 26th Ave S & S 200th St

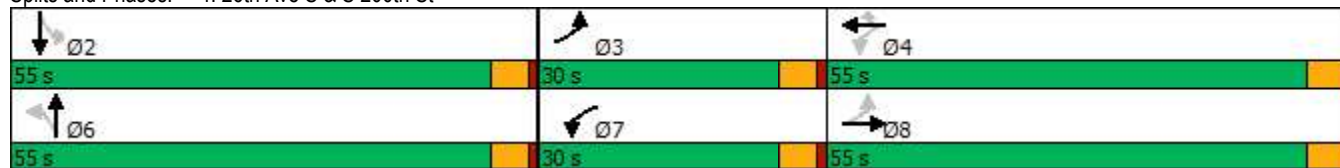

HCM 6th Signalized Intersection Summary
 4: 26th Ave S & S 200th St

07/14/2021



Movement	EBL	EBT	EBR	WBL	WBT	WBR	NBL	NBT	NBR	SBL	SBT	SBR
Lane Configurations												
Traffic Volume (veh/h)	6	173	42	74	245	3	44	125	110	34	158	16
Future Volume (veh/h)	6	173	42	74	245	3	44	125	110	34	158	16
Initial Q (Qb), veh	0	0	0	0	0	0	0	0	0	0	0	0
Ped-Bike Adj(A_pbT)	1.00		1.00	1.00		1.00	1.00		1.00	1.00		1.00
Parking Bus, Adj	1.00	1.00	1.00	1.00	1.00	1.00	1.00	1.00	1.00	1.00	1.00	1.00
Work Zone On Approach		No			No			No			No	
Adj Sat Flow, veh/h/ln	1423	1319	1245	1969	2089	1248	1555	1540	1584	2175	2115	2175
Adj Flow Rate, veh/h	7	199	48	85	282	3	51	144	126	39	182	18
Peak Hour Factor	0.87	0.87	0.87	0.87	0.87	0.87	0.87	0.87	0.87	0.87	0.87	0.87
Percent Heavy Veh, %	0	7	12	19	11	67	9	10	7	0	4	0
Cap, veh/h	398	547	129	559	711	359	405	398	323	415	960	94
Arrive On Green	0.01	0.27	0.27	0.08	0.34	0.34	0.26	0.26	0.26	0.26	0.26	0.26
Sat Flow, veh/h	1355	2012	474	1875	2089	1056	983	1534	1245	1290	3698	362
Grp Volume(v), veh/h	7	122	125	85	282	3	51	137	133	39	98	102
Grp Sat Flow(s),veh/h/ln	1355	1253	1233	1875	2089	1056	983	1463	1316	1290	2010	2050
Q Serve(g_s), s	0.1	3.0	3.1	1.2	4.0	0.1	1.6	2.9	3.2	1.0	1.5	1.5
Cycle Q Clear(g_c), s	0.1	3.0	3.1	1.2	4.0	0.1	3.1	2.9	3.2	4.2	1.5	1.5
Prop In Lane	1.00		0.38	1.00		1.00	1.00		0.95	1.00		0.18
Lane Grp Cap(c), veh/h	398	341	335	559	711	359	405	380	342	415	522	532
V/C Ratio(X)	0.02	0.36	0.37	0.15	0.40	0.01	0.13	0.36	0.39	0.09	0.19	0.19
Avail Cap(c_a), veh/h	1267	1631	1605	1634	2719	1375	1429	1904	1713	1759	2616	2669
HCM Platoon Ratio	1.00	1.00	1.00	1.00	1.00	1.00	1.00	1.00	1.00	1.00	1.00	1.00
Upstream Filter(l)	1.00	1.00	1.00	1.00	1.00	1.00	1.00	1.00	1.00	1.00	1.00	1.00
Uniform Delay (d), s/veh	10.0	11.3	11.3	8.6	9.7	8.4	12.3	11.6	11.7	13.4	11.1	11.1
Incr Delay (d2), s/veh	0.0	0.2	0.3	0.0	0.1	0.0	0.1	0.2	0.3	0.0	0.1	0.1
Initial Q Delay(d3),s/veh	0.0	0.0	0.0	0.0	0.0	0.0	0.0	0.0	0.0	0.0	0.0	0.0
%ile BackOfQ(50%),veh/ln	0.0	0.7	0.7	0.3	1.3	0.0	0.3	0.7	0.7	0.2	0.5	0.5
Unsig. Movement Delay, s/veh												
LnGrp Delay(d),s/veh	10.0	11.5	11.6	8.7	9.8	8.4	12.3	11.8	12.0	13.5	11.1	11.1
LnGrp LOS	A	B	B	A	A	A	B	B	B	B	B	B
Approach Vol, veh/h		254			370			321			239	
Approach Delay, s/veh		11.5			9.5			12.0			11.5	
Approach LOS		B			A			B			B	
Timer - Assigned Phs		2	3	4		6	7	8				
Phs Duration (G+Y+Rc), s		15.0	5.4	18.1		15.0	8.0	15.5				
Change Period (Y+Rc), s		5.0	5.0	5.0		5.0	5.0	5.0				
Max Green Setting (Gmax), s		50.0	25.0	50.0		50.0	25.0	50.0				
Max Q Clear Time (g_c+I1), s		6.2	2.1	6.0		5.2	3.2	5.1				
Green Ext Time (p_c), s		0.2	0.0	0.3		0.3	0.0	0.2				
Intersection Summary												
HCM 6th Ctrl Delay				11.0								
HCM 6th LOS				B								

Lanes, Volumes, Timings
 5: Des Moines Memorial Dr & Site Access

07/14/2021



Lane Group	WBL	WBR	NBT	NBR	SBL	SBT
Lane Configurations						
Traffic Volume (vph)	7	2	549	6	2	712
Future Volume (vph)	7	2	549	6	2	712
Ideal Flow (vphpl)	1900	1900	1900	1900	1900	1900
Link Speed (mph)	25		30			35
Link Distance (ft)	502		545			385
Travel Time (s)	13.7		12.4			7.5
Peak Hour Factor	0.92	0.92	0.92	0.92	0.92	0.92
Heavy Vehicles (%)	14%	50%	0%	33%	50%	0%
Shared Lane Traffic (%)						
Sign Control	Stop		Free			Free

Intersection Summary

Area Type: Other

Control Type: Unsignalized

HCM 6th TWSC
5: Des Moines Memorial Dr & Site Access

07/14/2021

Intersection						
Int Delay, s/veh	0.2					
Movement	WBL	WBR	NBT	NBR	SBL	SBT
Lane Configurations	↔		↔			↔
Traffic Vol, veh/h	7	2	549	6	2	712
Future Vol, veh/h	7	2	549	6	2	712
Conflicting Peds, #/hr	0	0	0	0	0	0
Sign Control	Stop	Stop	Free	Free	Free	Free
RT Channelized	-	None	-	None	-	None
Storage Length	0	-	-	-	-	-
Veh in Median Storage, #	0	-	0	-	-	0
Grade, %	0	-	0	-	-	0
Peak Hour Factor	92	92	92	92	92	92
Heavy Vehicles, %	14	50	0	33	50	0
Mvmt Flow	8	2	597	7	2	774

Major/Minor	Minor1	Major1	Major2		
Conflicting Flow All	1379	601	0	0	604
Stage 1	601	-	-	-	-
Stage 2	778	-	-	-	-
Critical Hdwy	6.54	6.7	-	-	4.6
Critical Hdwy Stg 1	5.54	-	-	-	-
Critical Hdwy Stg 2	5.54	-	-	-	-
Follow-up Hdwy	3.626	3.75	-	-	2.65
Pot Cap-1 Maneuver	150	422	-	-	778
Stage 1	525	-	-	-	-
Stage 2	433	-	-	-	-
Platoon blocked, %			-	-	-
Mov Cap-1 Maneuver	149	422	-	-	778
Mov Cap-2 Maneuver	149	-	-	-	-
Stage 1	525	-	-	-	-
Stage 2	431	-	-	-	-

Approach	WB	NB	SB
HCM Control Delay, s	26.9	0	0
HCM LOS	D		

Minor Lane/Major Mvmt	NBT	NBR	WBLn1	SBL	SBT
Capacity (veh/h)	-	-	174	778	-
HCM Lane V/C Ratio	-	-	0.056	0.003	-
HCM Control Delay (s)	-	-	26.9	9.6	0
HCM Lane LOS	-	-	D	A	A
HCM 95th %tile Q(veh)	-	-	0.2	0	-

Lanes, Volumes, Timings
 6: 12th PI S/West Site Access & S 200th St

07/14/2021



Lane Group	EBL	EBT	EBR	WBL	WBT	WBR	NBL	NBT	NBR	SBL	SBT	SBR
Lane Configurations												
Traffic Volume (vph)	3	196	7	14	278	2	3	0	11	2	0	1
Future Volume (vph)	3	196	7	14	278	2	3	0	11	2	0	1
Ideal Flow (vphpl)	1900	1900	1900	1900	1900	1900	1900	1900	1900	1900	1900	1900
Link Speed (mph)		35			35			25			25	
Link Distance (ft)		538			274			315			219	
Travel Time (s)		10.5			5.3			8.6			6.0	
Confl. Peds. (#/hr)			1	1								
Peak Hour Factor	0.91	0.91	0.91	0.91	0.91	0.91	0.91	0.91	0.91	0.91	0.91	0.91
Heavy Vehicles (%)	33%	6%	0%	0%	6%	0%	0%	0%	0%	50%	0%	0%
Shared Lane Traffic (%)												
Sign Control		Free			Free			Stop			Stop	

Intersection Summary

Area Type: Other

Control Type: Unsignalized

HCM 6th TWSC
6: 12th PI S/West Site Access & S 200th St

07/14/2021

Intersection												
Int Delay, s/veh	0.6											
Movement	EBL	EBT	EBR	WBL	WBT	WBR	NBL	NBT	NBR	SBL	SBT	SBR
Lane Configurations		↕			↕			↕			↕	
Traffic Vol, veh/h	3	196	7	14	278	2	3	0	11	2	0	1
Future Vol, veh/h	3	196	7	14	278	2	3	0	11	2	0	1
Conflicting Peds, #/hr	0	0	1	1	0	0	0	0	0	0	0	0
Sign Control	Free	Free	Free	Free	Free	Free	Stop	Stop	Stop	Stop	Stop	Stop
RT Channelized	-	-	None	-	-	None	-	-	None	-	-	None
Storage Length	-	-	-	-	-	-	-	-	-	-	-	-
Veh in Median Storage, #	-	0	-	-	0	-	-	0	-	-	0	-
Grade, %	-	0	-	-	0	-	-	0	-	-	0	-
Peak Hour Factor	91	91	91	91	91	91	91	91	91	91	91	91
Heavy Vehicles, %	33	6	0	0	6	0	0	0	0	50	0	0
Mvmt Flow	3	215	8	15	305	2	3	0	12	2	0	1

Major/Minor	Major1			Major2			Minor1			Minor2		
Conflicting Flow All	307	0	0	224	0	0	563	563	220	567	566	306
Stage 1	-	-	-	-	-	-	226	226	-	336	336	-
Stage 2	-	-	-	-	-	-	337	337	-	231	230	-
Critical Hdwy	4.43	-	-	4.1	-	-	7.1	6.5	6.2	7.6	6.5	6.2
Critical Hdwy Stg 1	-	-	-	-	-	-	6.1	5.5	-	6.6	5.5	-
Critical Hdwy Stg 2	-	-	-	-	-	-	6.1	5.5	-	6.6	5.5	-
Follow-up Hdwy	2.497	-	-	2.2	-	-	3.5	4	3.3	3.95	4	3.3
Pot Cap-1 Maneuver	1097	-	-	1357	-	-	440	438	825	370	436	739
Stage 1	-	-	-	-	-	-	781	721	-	589	645	-
Stage 2	-	-	-	-	-	-	681	645	-	676	718	-
Platoon blocked, %	-	-	-	-	-	-	-	-	-	-	-	-
Mov Cap-1 Maneuver	1097	-	-	1356	-	-	433	431	824	360	429	739
Mov Cap-2 Maneuver	-	-	-	-	-	-	433	431	-	360	429	-
Stage 1	-	-	-	-	-	-	778	718	-	587	637	-
Stage 2	-	-	-	-	-	-	671	637	-	664	715	-

Approach	EB			WB			NB			SB		
HCM Control Delay, s	0.1			0.4			10.3			13.4		
HCM LOS							B			B		

Minor Lane/Major Mvmt	NBLn1	EBL	EBT	EBR	WBL	WBT	WBR	SBLn1
Capacity (veh/h)	690	1097	-	-	1356	-	-	434
HCM Lane V/C Ratio	0.022	0.003	-	-	0.011	-	-	0.008
HCM Control Delay (s)	10.3	8.3	0	-	7.7	0	-	13.4
HCM Lane LOS	B	A	A	-	A	A	-	B
HCM 95th %tile Q(veh)	0.1	0	-	-	0	-	-	0

Lanes, Volumes, Timings
 7: S 200th St & East Site Access

07/14/2021



Lane Group	EBL	EBT	WBT	WBR	SBL	SBR
Lane Configurations						
Traffic Volume (vph)	1	213	296	5	6	1
Future Volume (vph)	1	213	296	5	6	1
Ideal Flow (vphpl)	1900	1900	1900	1900	1900	1900
Link Speed (mph)		30	35		25	
Link Distance (ft)		256	549		207	
Travel Time (s)		5.8	10.7		5.6	
Peak Hour Factor	0.92	0.92	0.92	0.92	0.92	0.92
Heavy Vehicles (%)	0%	1%	1%	40%	33%	0%
Shared Lane Traffic (%)						
Sign Control		Free	Free		Stop	

Intersection Summary

Area Type: Other
 Control Type: Unsignalized

Intersection						
Int Delay, s/veh	0.2					
Movement	EBL	EBT	WBT	WBR	SBL	SBR
Lane Configurations		↕	↕		↕	
Traffic Vol, veh/h	1	213	296	5	6	1
Future Vol, veh/h	1	213	296	5	6	1
Conflicting Peds, #/hr	0	0	0	0	0	0
Sign Control	Free	Free	Free	Free	Stop	Stop
RT Channelized	-	None	-	None	-	None
Storage Length	-	-	-	-	0	-
Veh in Median Storage, #	-	0	0	-	0	-
Grade, %	-	0	0	-	0	-
Peak Hour Factor	92	92	92	92	92	92
Heavy Vehicles, %	0	1	1	40	33	0
Mvmt Flow	1	232	322	5	7	1

Major/Minor	Major1	Major2	Minor2		
Conflicting Flow All	327	0	-	0	559 325
Stage 1	-	-	-	-	325 -
Stage 2	-	-	-	-	234 -
Critical Hdwy	4.1	-	-	-	6.73 6.2
Critical Hdwy Stg 1	-	-	-	-	5.73 -
Critical Hdwy Stg 2	-	-	-	-	5.73 -
Follow-up Hdwy	2.2	-	-	-	3.797 3.3
Pot Cap-1 Maneuver	1244	-	-	-	441 721
Stage 1	-	-	-	-	668 -
Stage 2	-	-	-	-	737 -
Platoon blocked, %		-	-	-	
Mov Cap-1 Maneuver	1244	-	-	-	441 721
Mov Cap-2 Maneuver	-	-	-	-	441 -
Stage 1	-	-	-	-	667 -
Stage 2	-	-	-	-	737 -

Approach	EB	WB	SB
HCM Control Delay, s	0	0	12.8
HCM LOS			B

Minor Lane/Major Mvmt	EBL	EBT	WBT	WBR	SBLn1
Capacity (veh/h)	1244	-	-	-	467
HCM Lane V/C Ratio	0.001	-	-	-	0.016
HCM Control Delay (s)	7.9	0	-	-	12.8
HCM Lane LOS	A	A	-	-	B
HCM 95th %tile Q(veh)	0	-	-	-	0.1

Lanes, Volumes, Timings
1: Des Moines Memorial Dr & S 192nd St

07/14/2021



Lane Group	EBL	EBT	EBR	WBL	WBT	WBR	NBL	NBT	NBR	SBL	SBT	SBR
Lane Configurations												
Traffic Volume (vph)	20	28	38	44	30	11	18	588	24	10	809	14
Future Volume (vph)	20	28	38	44	30	11	18	588	24	10	809	14
Ideal Flow (vphpl)	1900	1900	1900	1900	1900	1900	1900	1900	1900	1900	1900	1900
Storage Length (ft)	150		0	200		0	150		0	150		0
Storage Lanes	1		0	1		0	1		0	1		0
Taper Length (ft)	25			25			25			25		
Right Turn on Red			Yes			Yes			Yes			Yes
Link Speed (mph)		35			25			35				35
Link Distance (ft)		1090			1011			616				766
Travel Time (s)		21.2			27.6			12.0				14.9
Peak Hour Factor	0.94	0.94	0.94	0.94	0.94	0.94	0.94	0.94	0.94	0.94	0.94	0.94
Heavy Vehicles (%)	15%	7%	0%	7%	3%	18%	11%	1%	17%	90%	1%	21%
Shared Lane Traffic (%)												
Turn Type	pm+pt	NA		pm+pt	NA		Prot	NA		Prot	NA	
Protected Phases	3	8		7	4		5	2		1	6	
Permitted Phases	8			4								
Detector Phase	3	8		7	4		5	2		1	6	
Switch Phase												
Minimum Initial (s)	5.0	5.0		5.0	5.0		6.0	12.0		10.0	12.0	
Minimum Split (s)	10.0	27.0		10.0	10.0		12.0	22.0		16.0	22.0	
Total Split (s)	20.0	35.0		20.0	35.0		21.0	65.0		36.0	65.0	
Total Split (%)	12.8%	22.4%		12.8%	22.4%		13.5%	41.7%		23.1%	41.7%	
Yellow Time (s)	4.0	4.0		4.0	4.0		4.0	4.0		4.0	4.0	
All-Red Time (s)	1.0	1.0		1.0	1.0		2.0	1.0		2.0	1.0	
Lost Time Adjust (s)	0.0	0.0		0.0	0.0		0.0	0.0		0.0	0.0	
Total Lost Time (s)	5.0	5.0		5.0	5.0		6.0	5.0		6.0	5.0	
Lead/Lag	Lead	Lag		Lead	Lag		Lead	Lag		Lead	Lag	
Lead-Lag Optimize?	Yes	Yes		Yes	Yes		Yes	Yes		Yes	Yes	
Recall Mode	None	None		None	None		None	Min		None	Min	

Intersection Summary

Area Type: Other

Cycle Length: 156

Actuated Cycle Length: 78.8

Natural Cycle: 90

Control Type: Actuated-Uncoordinated

Splits and Phases: 1: Des Moines Memorial Dr & S 192nd St

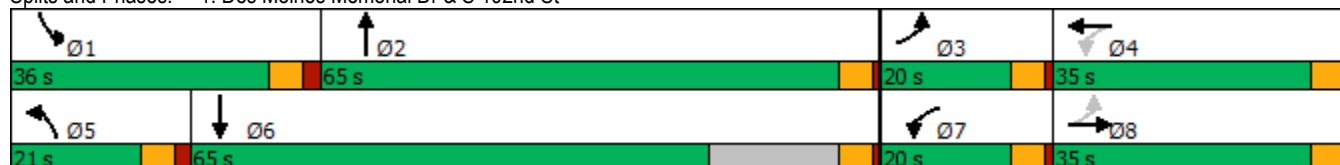

HCM 6th Signalized Intersection Summary

1: Des Moines Memorial Dr & S 192nd St

07/14/2021

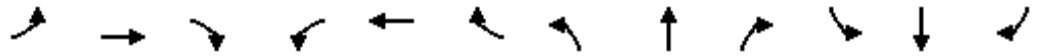

Movement	EBL	EBT	EBR	WBL	WBT	WBR	NBL	NBT	NBR	SBL	SBT	SBR
Lane Configurations												
Traffic Volume (veh/h)	20	28	38	44	30	11	18	588	24	10	809	14
Future Volume (veh/h)	20	28	38	44	30	11	18	588	24	10	809	14
Initial Q (Qb), veh	0	0	0	0	0	0	0	0	0	0	0	0
Ped-Bike Adj(A_pbT)	1.00		1.00	1.00		1.00	1.00		1.00	1.00		1.00
Parking Bus, Adj	1.00	1.00	1.00	1.00	1.00	1.00	1.00	1.00	1.00	1.00	1.00	1.00
Work Zone On Approach		No			No			No			No	
Adj Sat Flow, veh/h/ln	1678	1796	1900	1796	1856	1633	1737	1885	1648	566	1885	1589
Adj Flow Rate, veh/h	21	30	40	47	32	12	19	626	26	11	861	15
Peak Hour Factor	0.94	0.94	0.94	0.94	0.94	0.94	0.94	0.94	0.94	0.94	0.94	0.94
Percent Heavy Veh, %	15	7	0	7	3	18	11	1	17	90	1	21
Cap, veh/h	224	40	53	215	100	37	45	940	39	15	968	17
Arrive On Green	0.02	0.06	0.06	0.05	0.08	0.08	0.03	0.52	0.52	0.03	0.52	0.52
Sat Flow, veh/h	1598	698	931	1711	1286	482	1654	1797	75	539	1847	32
Grp Volume(v), veh/h	21	0	70	47	0	44	19	0	652	11	0	876
Grp Sat Flow(s),veh/h/ln	1598	0	1629	1711	0	1769	1654	0	1872	539	0	1879
Q Serve(g_s), s	0.7	0.0	2.6	1.5	0.0	1.4	0.7	0.0	15.4	1.2	0.0	25.2
Cycle Q Clear(g_c), s	0.7	0.0	2.6	1.5	0.0	1.4	0.7	0.0	15.4	1.2	0.0	25.2
Prop In Lane	1.00		0.57	1.00		0.27	1.00		0.04	1.00		0.02
Lane Grp Cap(c), veh/h	224	0	93	215	0	137	45	0	979	15	0	985
V/C Ratio(X)	0.09	0.00	0.75	0.22	0.00	0.32	0.42	0.00	0.67	0.73	0.00	0.89
Avail Cap(c_a), veh/h	581	0	807	561	0	876	410	0	1854	267	0	1861
HCM Platoon Ratio	1.00	1.00	1.00	1.00	1.00	1.00	1.00	1.00	1.00	1.00	1.00	1.00
Upstream Filter(l)	1.00	0.00	1.00	1.00	0.00	1.00	1.00	0.00	1.00	1.00	0.00	1.00
Uniform Delay (d), s/veh	25.9	0.0	28.1	25.2	0.0	26.4	29.0	0.0	10.6	29.2	0.0	12.9
Incr Delay (d2), s/veh	0.1	0.0	4.5	0.2	0.0	0.5	2.3	0.0	0.3	87.4	0.0	1.2
Initial Q Delay(d3),s/veh	0.0	0.0	0.0	0.0	0.0	0.0	0.0	0.0	0.0	0.0	0.0	0.0
%ile BackOfQ(50%),veh/ln	0.3	0.0	1.1	0.6	0.0	0.6	0.3	0.0	5.0	0.5	0.0	8.4
Unsig. Movement Delay, s/veh												
LnGrp Delay(d),s/veh	26.0	0.0	32.7	25.3	0.0	26.9	31.4	0.0	10.9	116.6	0.0	14.0
LnGrp LOS	C	A	C	C	A	C	C	A	B	F	A	B
Approach Vol, veh/h		91			91			671				887
Approach Delay, s/veh		31.1			26.1			11.4				15.3
Approach LOS		C			C			B				B
Timer - Assigned Phs	1	2	3	4	5	6	7	8				
Phs Duration (G+Y+Rc), s	7.7	36.7	6.5	9.7	7.6	36.7	7.7	8.5				
Change Period (Y+Rc), s	6.0	5.0	5.0	5.0	6.0	5.0	5.0	5.0				
Max Green Setting (Gmax), s	30.0	60.0	15.0	30.0	15.0	60.0	15.0	30.0				
Max Q Clear Time (g_c+I1), s	3.2	17.4	2.7	3.4	2.7	27.2	3.5	4.6				
Green Ext Time (p_c), s	0.0	3.0	0.0	0.1	0.0	4.6	0.0	0.2				
Intersection Summary												
HCM 6th Ctrl Delay			15.2									
HCM 6th LOS			B									

Lanes, Volumes, Timings
2: 1st Ave S (SR 509) & S 199th St

07/14/2021



Lane Group	EBL	EBT	EBR	WBL	WBT	WBR	NBL	NBT	NBR	SBL	SBT	SBR
Lane Configurations		↕	↗		↕		↗	↕		↗	↕↗	
Traffic Volume (vph)	52	77	9	52	62	75	6	319	55	237	557	27
Future Volume (vph)	52	77	9	52	62	75	6	319	55	237	557	27
Ideal Flow (vphpl)	1750	1750	1750	1750	1750	1750	1750	1750	1750	1750	1750	1750
Storage Length (ft)	0		0	0		0	100		0	150		150
Storage Lanes	0		1	0		0	1		0	1		1
Taper Length (ft)	25			25			25			25		
Right Turn on Red			Yes			Yes			Yes			Yes
Link Speed (mph)		25			25			35			35	
Link Distance (ft)		134			340			192			566	
Travel Time (s)		3.7			9.3			3.7			11.0	
Confl. Peds. (#/hr)	6					6	3					3
Peak Hour Factor	1.00	1.00	1.00	1.00	1.00	1.00	1.00	1.00	1.00	1.00	1.00	1.00
Heavy Vehicles (%)	0%	0%	0%	0%	0%	0%	0%	1%	0%	0%	1%	4%
Shared Lane Traffic (%)												
Turn Type	Perm	NA	Perm	Perm	NA		pm+pt	NA		pm+pt	NA	
Protected Phases		4			8		5	2		1		6
Permitted Phases	4		4	8			2			6		
Detector Phase	4	4	4	8	8		5	2		1		6
Switch Phase												
Minimum Initial (s)	7.0	7.0	7.0	7.0	7.0		5.0	10.0		5.0		10.0
Minimum Split (s)	35.9	35.9	35.9	35.9	35.9		10.5	26.9		10.5		26.9
Total Split (s)	35.9	35.9	35.9	35.9	35.9		25.5	55.9		25.5		55.9
Total Split (%)	30.6%	30.6%	30.6%	30.6%	30.6%		21.7%	47.7%		21.7%		47.7%
Yellow Time (s)	3.9	3.9	3.9	3.9	3.9		3.5	3.9		3.5		3.9
All-Red Time (s)	2.0	2.0	2.0	2.0	2.0		2.0	2.0		2.0		2.0
Lost Time Adjust (s)		0.0	0.0		0.0		0.0	0.0		0.0		0.0
Total Lost Time (s)		5.9	5.9		5.9		5.5	5.9		5.5		5.9
Lead/Lag							Lead	Lag		Lead		Lag
Lead-Lag Optimize?							Yes	Yes		Yes		Yes
Recall Mode	None	None	None	None	None		None	Min		None		Min

Intersection Summary

Area Type: Other

Cycle Length: 117.3

Actuated Cycle Length: 68.4

Natural Cycle: 75

Control Type: Actuated-Uncoordinated

Splits and Phases: 2: 1st Ave S (SR 509) & S 199th St

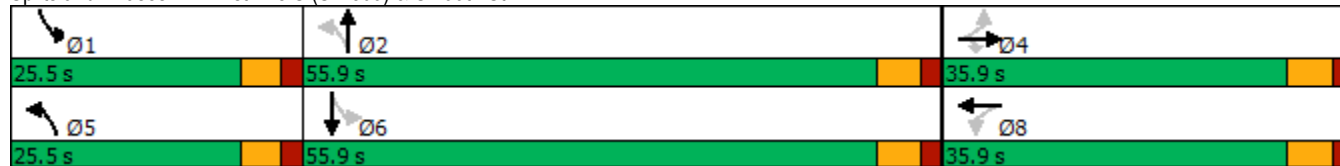

HCM 6th Signalized Intersection Summary
 2: 1st Ave S (SR 509) & S 199th St

07/14/2021



Movement	EBL	EBT	EBR	WBL	WBT	WBR	NBL	NBT	NBR	SBL	SBT	SBR
Lane Configurations		↕	↗		↕		↗	↖		↖	↕	↖
Traffic Volume (veh/h)	52	77	9	52	62	75	6	319	55	237	557	27
Future Volume (veh/h)	52	77	9	52	62	75	6	319	55	237	557	27
Initial Q (Qb), veh	0	0	0	0	0	0	0	0	0	0	0	0
Ped-Bike Adj(A_pbT)	0.99		0.99	0.99		0.99	1.00		1.00	1.00		1.00
Parking Bus, Adj	1.00	1.00	1.00	1.00	1.00	1.00	1.00	1.00	1.00	1.00	1.00	1.00
Work Zone On Approach		No			No			No			No	
Adj Sat Flow, veh/h/ln	1750	1750	1750	1750	1750	1750	1750	1736	1750	1750	1736	1695
Adj Flow Rate, veh/h	52	77	9	52	62	75	6	319	55	237	557	27
Peak Hour Factor	1.00	1.00	1.00	1.00	1.00	1.00	1.00	1.00	1.00	1.00	1.00	1.00
Percent Heavy Veh, %	0	0	0	0	0	0	0	1	0	0	1	4
Cap, veh/h	196	241	314	147	135	128	405	470	81	479	1431	69
Arrive On Green	0.21	0.21	0.21	0.21	0.21	0.21	0.01	0.33	0.33	0.13	0.45	0.45
Sat Flow, veh/h	465	1128	1471	278	633	600	1667	1442	249	1667	3202	155
Grp Volume(v), veh/h	129	0	9	189	0	0	6	0	374	237	287	297
Grp Sat Flow(s),veh/h/ln	1594	0	1471	1511	0	0	1667	0	1690	1667	1650	1708
Q Serve(g_s), s	0.0	0.0	0.3	2.2	0.0	0.0	0.1	0.0	10.0	4.4	6.1	6.1
Cycle Q Clear(g_c), s	3.3	0.0	0.3	5.7	0.0	0.0	0.1	0.0	10.0	4.4	6.1	6.1
Prop In Lane	0.40		1.00	0.28		0.40	1.00		0.15	1.00		0.09
Lane Grp Cap(c), veh/h	437	0	314	410	0	0	405	0	551	479	737	763
V/C Ratio(X)	0.30	0.00	0.03	0.46	0.00	0.00	0.01	0.00	0.68	0.49	0.39	0.39
Avail Cap(c_a), veh/h	963	0	846	939	0	0	1031	0	1621	905	1582	1638
HCM Platoon Ratio	1.00	1.00	1.00	1.00	1.00	1.00	1.00	1.00	1.00	1.00	1.00	1.00
Upstream Filter(l)	1.00	0.00	1.00	1.00	0.00	0.00	1.00	0.00	1.00	1.00	1.00	1.00
Uniform Delay (d), s/veh	17.4	0.0	16.2	18.3	0.0	0.0	11.6	0.0	15.2	9.6	9.7	9.7
Incr Delay (d2), s/veh	0.6	0.0	0.1	1.4	0.0	0.0	0.0	0.0	3.1	0.8	0.7	0.7
Initial Q Delay(d3),s/veh	0.0	0.0	0.0	0.0	0.0	0.0	0.0	0.0	0.0	0.0	0.0	0.0
%ile BackOfQ(50%),veh/ln	1.3	0.0	0.1	2.0	0.0	0.0	0.0	0.0	3.7	1.3	1.9	1.9
Unsig. Movement Delay, s/veh												
LnGrp Delay(d),s/veh	18.1	0.0	16.3	19.7	0.0	0.0	11.6	0.0	18.3	10.4	10.4	10.4
LnGrp LOS	B	A	B	B	A	A	B	A	B	B	B	B
Approach Vol, veh/h		138			189			380			821	
Approach Delay, s/veh		17.9			19.7			18.2			10.4	
Approach LOS		B			B			B			B	
Timer - Assigned Phs	1	2		4	5	6		8				
Phs Duration (G+Y+Rc), s	12.2	22.9		17.0	5.9	29.2		17.0				
Change Period (Y+Rc), s	5.5	5.9		5.9	5.5	5.9		5.9				
Max Green Setting (Gmax), s	20.0	50.0		30.0	20.0	50.0		30.0				
Max Q Clear Time (g_c+I1), s	6.4	12.0		5.3	2.1	8.1		7.7				
Green Ext Time (p_c), s	0.5	4.9		1.2	0.0	7.9		1.8				
Intersection Summary												
HCM 6th Ctrl Delay			14.2									
HCM 6th LOS			B									

Lanes, Volumes, Timings
 3: Des Moines Memorial Dr & S 200th St

07/14/2021



Lane Group	EBL	EBT	EBR	WBL	WBT	WBR	NBL	NBT	NBR	SBL	SBT	SBR
Lane Configurations												
Traffic Volume (vph)	29	194	146	72	163	242	14	354	31	151	742	12
Future Volume (vph)	29	194	146	72	163	242	14	354	31	151	742	12
Ideal Flow (vphpl)	1900	1900	1900	1900	1900	1900	1900	1900	1900	1900	1900	1900
Storage Length (ft)	0		200	200		350	200		0	200		0
Storage Lanes	1		1	1		1	1		0	1		0
Taper Length (ft)	25			25			25			25		
Right Turn on Red			Yes			Yes			Yes			Yes
Link Speed (mph)		25			35			35			35	
Link Distance (ft)		533			538			421			545	
Travel Time (s)		14.5			10.5			8.2			10.6	
Confl. Peds. (#/hr)			3	3								
Peak Hour Factor	0.98	0.98	0.98	0.98	0.98	0.98	0.98	0.98	0.98	0.98	0.98	0.98
Heavy Vehicles (%)	0%	1%	5%	1%	4%	5%	29%	2%	3%	7%	1%	0%
Shared Lane Traffic (%)												
Turn Type	pm+pt	NA		pm+pt	NA	Perm	pm+pt	NA		pm+pt	NA	
Protected Phases	3	8		7	4		5	2		1	6	
Permitted Phases	8			4		4	2			6		
Detector Phase	3	8		7	4	4	5	2		1	6	
Switch Phase												
Minimum Initial (s)	5.0	5.0		5.0	5.0	5.0	5.0	5.0		5.0	5.0	
Minimum Split (s)	10.0	30.0		10.0	31.0	31.0	10.0	32.0		10.0	30.0	
Total Split (s)	25.0	40.0		25.0	40.0	40.0	25.0	55.0		25.0	55.0	
Total Split (%)	17.2%	27.6%		17.2%	27.6%	27.6%	17.2%	37.9%		17.2%	37.9%	
Yellow Time (s)	4.0	4.0		4.0	4.0	4.0	4.0	4.0		4.0	4.0	
All-Red Time (s)	1.0	1.0		1.0	1.0	1.0	1.0	1.0		1.0	1.0	
Lost Time Adjust (s)	0.0	0.0		0.0	0.0	0.0	0.0	0.0		0.0	0.0	
Total Lost Time (s)	5.0	5.0		5.0	5.0	5.0	5.0	5.0		5.0	5.0	
Lead/Lag	Lead	Lag		Lead	Lag	Lag	Lead	Lag		Lead	Lag	
Lead-Lag Optimize?	Yes	Yes		Yes	Yes	Yes	Yes	Yes		Yes	Yes	
Recall Mode	None	None		None	None	None	None	None		None	None	

Intersection Summary

Area Type: Other

Cycle Length: 145

Actuated Cycle Length: 104.4

Natural Cycle: 85

Control Type: Actuated-Uncoordinated

Splits and Phases: 3: Des Moines Memorial Dr & S 200th St

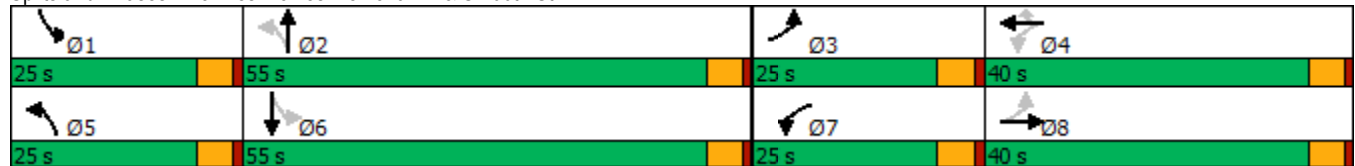

HCM 6th Signalized Intersection Summary
 3: Des Moines Memorial Dr & S 200th St

07/14/2021



Movement	EBL	EBT	EBR	WBL	WBT	WBR	NBL	NBT	NBR	SBL	SBT	SBR
Lane Configurations												
Traffic Volume (veh/h)	29	194	146	72	163	242	14	354	31	151	742	12
Future Volume (veh/h)	29	194	146	72	163	242	14	354	31	151	742	12
Initial Q (Qb), veh	0	0	0	0	0	0	0	0	0	0	0	0
Ped-Bike Adj(A_pbT)	1.00		0.99	1.00		0.99	1.00		1.00	1.00		1.00
Parking Bus, Adj	1.00	1.00	1.00	1.00	1.00	1.00	1.00	1.00	1.00	1.00	1.00	1.00
Work Zone On Approach		No			No			No			No	
Adj Sat Flow, veh/h/ln	1900	1885	1826	1885	1841	1826	1470	1870	1856	1796	1885	1900
Adj Flow Rate, veh/h	30	198	149	73	166	247	14	361	32	154	757	12
Peak Hour Factor	0.98	0.98	0.98	0.98	0.98	0.98	0.98	0.98	0.98	0.98	0.98	0.98
Percent Heavy Veh, %	0	1	5	1	4	5	29	2	3	7	1	0
Cap, veh/h	320	247	186	225	487	407	160	704	62	447	872	14
Arrive On Green	0.03	0.25	0.25	0.05	0.26	0.26	0.02	0.42	0.42	0.07	0.47	0.47
Sat Flow, veh/h	1810	996	749	1795	1841	1539	1400	1693	150	1711	1851	29
Grp Volume(v), veh/h	30	0	347	73	166	247	14	0	393	154	0	769
Grp Sat Flow(s),veh/h/ln	1810	0	1745	1795	1841	1539	1400	0	1843	1711	0	1880
Q Serve(g_s), s	1.1	0.0	17.1	2.7	6.7	12.9	0.5	0.0	14.5	4.4	0.0	33.5
Cycle Q Clear(g_c), s	1.1	0.0	17.1	2.7	6.7	12.9	0.5	0.0	14.5	4.4	0.0	33.5
Prop In Lane	1.00		0.43	1.00		1.00	1.00		0.08	1.00		0.02
Lane Grp Cap(c), veh/h	320	0	432	225	487	407	160	0	766	447	0	886
V/C Ratio(X)	0.09	0.00	0.80	0.32	0.34	0.61	0.09	0.00	0.51	0.34	0.00	0.87
Avail Cap(c_a), veh/h	663	0	666	534	703	588	442	0	1006	697	0	1026
HCM Platoon Ratio	1.00	1.00	1.00	1.00	1.00	1.00	1.00	1.00	1.00	1.00	1.00	1.00
Upstream Filter(l)	1.00	0.00	1.00	1.00	1.00	1.00	1.00	0.00	1.00	1.00	0.00	1.00
Uniform Delay (d), s/veh	24.5	0.0	32.4	25.5	27.2	29.5	19.5	0.0	19.9	13.9	0.0	21.7
Incr Delay (d2), s/veh	0.1	0.0	7.5	0.8	0.9	3.1	0.2	0.0	1.1	0.5	0.0	8.5
Initial Q Delay(d3),s/veh	0.0	0.0	0.0	0.0	0.0	0.0	0.0	0.0	0.0	0.0	0.0	0.0
%ile BackOfQ(50%),veh/ln	0.5	0.0	8.0	1.2	3.0	5.1	0.2	0.0	6.1	1.6	0.0	15.6
Unsig. Movement Delay, s/veh												
LnGrp Delay(d),s/veh	24.6	0.0	39.9	26.4	28.1	32.6	19.7	0.0	21.0	14.3	0.0	30.2
LnGrp LOS	C	A	D	C	C	C	B	A	C	B	A	C
Approach Vol, veh/h		377			486			407			923	
Approach Delay, s/veh		38.7			30.1			21.0			27.5	
Approach LOS		D			C			C			C	
Timer - Assigned Phs	1	2	3	4	5	6	7	8				
Phs Duration (G+Y+Rc), s	11.6	43.1	7.7	29.3	6.5	48.2	9.2	27.7				
Change Period (Y+Rc), s	5.0	5.0	5.0	5.0	5.0	5.0	5.0	5.0				
Max Green Setting (Gmax), s	20.0	50.0	20.0	35.0	20.0	50.0	20.0	35.0				
Max Q Clear Time (g_c+I1), s	6.4	16.5	3.1	14.9	2.5	35.5	4.7	19.1				
Green Ext Time (p_c), s	0.3	5.1	0.0	3.5	0.0	7.7	0.1	3.5				
Intersection Summary												
HCM 6th Ctrl Delay			28.8									
HCM 6th LOS			C									

Lanes, Volumes, Timings
4: 26th Ave S & S 200th St

07/14/2021

Lane Group	EBL	EBT	EBR	WBL	WBT	WBR	NBL	NBT	NBR	SBL	SBT	SBR
Lane Configurations												
Traffic Volume (vph)	16	319	86	85	381	7	104	135	54	31	281	11
Future Volume (vph)	16	319	86	85	381	7	104	135	54	31	281	11
Ideal Flow (vphpl)	1900	1900	1900	1900	1900	1900	1900	1900	1900	1900	1900	1900
Grade (%)		9%			-9%			6%			-7%	
Storage Length (ft)	150		150	175		0	100		0	100		0
Storage Lanes	1		1	1		1	1		0	1		0
Taper Length (ft)	25			25			25			25		
Right Turn on Red			Yes			Yes			Yes			Yes
Link Speed (mph)		35			35			35			35	
Link Distance (ft)		707			875			1004			1058	
Travel Time (s)		13.8			17.0			19.6			20.6	
Confl. Peds. (#/hr)	1		1	1		1			1	1		
Peak Hour Factor	0.94	0.94	0.94	0.94	0.94	0.94	0.94	0.94	0.94	0.94	0.94	0.94
Heavy Vehicles (%)	0%	2%	1%	13%	5%	29%	2%	7%	11%	0%	3%	0%
Shared Lane Traffic (%)												
Turn Type	pm+pt	NA		pm+pt	NA	Perm	Perm	NA		Perm	NA	
Protected Phases	3	8		7	4			6			2	
Permitted Phases	8			4		4	6			2		
Detector Phase	3	8		7	4	4	6	6		2	2	
Switch Phase												
Minimum Initial (s)	5.0	10.0		5.0	10.0	10.0	10.0	10.0		10.0	10.0	
Minimum Split (s)	10.0	36.0		10.0	40.0	40.0	35.0	35.0		30.0	30.0	
Total Split (s)	30.0	55.0		30.0	55.0	55.0	55.0	55.0		55.0	55.0	
Total Split (%)	21.4%	39.3%		21.4%	39.3%	39.3%	39.3%	39.3%		39.3%	39.3%	
Yellow Time (s)	4.0	4.0		4.0	4.0	4.0	4.0	4.0		4.0	4.0	
All-Red Time (s)	1.0	1.0		1.0	1.0	1.0	1.0	1.0		1.0	1.0	
Lost Time Adjust (s)	0.0	0.0		0.0	0.0	0.0	0.0	0.0		0.0	0.0	
Total Lost Time (s)	5.0	5.0		5.0	5.0	5.0	5.0	5.0		5.0	5.0	
Lead/Lag	Lead	Lag		Lead	Lag	Lag						
Lead-Lag Optimize?	Yes	Yes		Yes	Yes	Yes						
Recall Mode	None	Min		None	Min	Min	None	None		None	None	

Intersection Summary

Area Type: Other

Cycle Length: 140

Actuated Cycle Length: 47.8

Natural Cycle: 85

Control Type: Actuated-Uncoordinated

Splits and Phases: 4: 26th Ave S & S 200th St

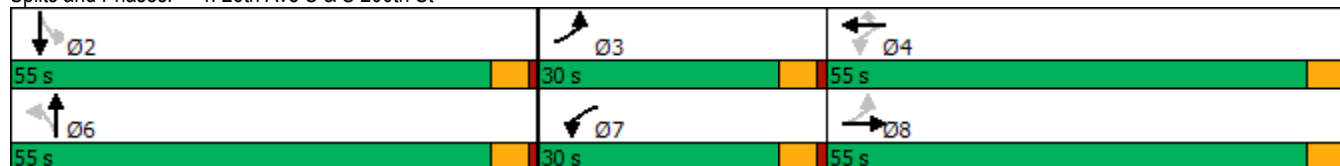

HCM 6th Signalized Intersection Summary

4: 26th Ave S & S 200th St

07/14/2021



Movement	EBL	EBT	EBR	WBL	WBT	WBR	NBL	NBT	NBR	SBL	SBT	SBR
Lane Configurations												
Traffic Volume (veh/h)	16	319	86	85	381	7	104	135	54	31	281	11
Future Volume (veh/h)	16	319	86	85	381	7	104	135	54	31	281	11
Initial Q (Qb), veh	0	0	0	0	0	0	0	0	0	0	0	0
Ped-Bike Adj(A_pbT)	1.00		1.00	1.00		1.00	1.00		1.00	1.00		1.00
Parking Bus, Adj	1.00	1.00	1.00	1.00	1.00	1.00	1.00	1.00	1.00	1.00	1.00	1.00
Work Zone On Approach		No			No			No			No	
Adj Sat Flow, veh/h/ln	1423	1393	1408	2059	2179	1819	1658	1584	1525	2175	2130	2175
Adj Flow Rate, veh/h	17	339	91	90	405	7	111	144	57	33	299	12
Peak Hour Factor	0.94	0.94	0.94	0.94	0.94	0.94	0.94	0.94	0.94	0.94	0.94	0.94
Percent Heavy Veh, %	0	2	1	13	5	29	2	7	11	0	3	0
Cap, veh/h	342	549	145	470	706	499	381	565	214	474	1051	42
Arrive On Green	0.02	0.27	0.27	0.08	0.32	0.32	0.26	0.26	0.26	0.26	0.26	0.26
Sat Flow, veh/h	1355	2070	548	1961	2179	1540	946	2133	810	1373	3966	159
Grp Volume(v), veh/h	17	215	215	90	405	7	111	100	101	33	152	159
Grp Sat Flow(s),veh/h/ln	1355	1324	1294	1961	2179	1540	946	1505	1437	1373	2024	2101
Q Serve(g_s), s	0.3	5.5	5.6	1.2	5.9	0.1	4.1	2.0	2.1	0.8	2.3	2.3
Cycle Q Clear(g_c), s	0.3	5.5	5.6	1.2	5.9	0.1	6.4	2.0	2.1	2.9	2.3	2.3
Prop In Lane	1.00		0.42	1.00		1.00	1.00		0.56	1.00		0.08
Lane Grp Cap(c), veh/h	342	351	344	470	706	499	381	399	381	474	536	557
V/C Ratio(X)	0.05	0.61	0.63	0.19	0.57	0.01	0.29	0.25	0.27	0.07	0.28	0.29
Avail Cap(c_a), veh/h	1192	1718	1679	1585	2828	1998	1358	1953	1865	1892	2626	2727
HCM Platoon Ratio	1.00	1.00	1.00	1.00	1.00	1.00	1.00	1.00	1.00	1.00	1.00	1.00
Upstream Filter(l)	1.00	1.00	1.00	1.00	1.00	1.00	1.00	1.00	1.00	1.00	1.00	1.00
Uniform Delay (d), s/veh	10.1	12.4	12.5	9.1	10.8	8.8	13.8	11.1	11.2	12.3	11.3	11.3
Incr Delay (d2), s/veh	0.0	0.6	0.7	0.1	0.3	0.0	0.2	0.1	0.1	0.0	0.1	0.1
Initial Q Delay(d3),s/veh	0.0	0.0	0.0	0.0	0.0	0.0	0.0	0.0	0.0	0.0	0.0	0.0
%ile BackOfQ(50%),veh/ln	0.1	1.3	1.3	0.4	2.1	0.0	0.7	0.5	0.5	0.2	0.8	0.8
Unsig. Movement Delay, s/veh												
LnGrp Delay(d),s/veh	10.1	13.1	13.2	9.2	11.1	8.8	14.0	11.3	11.3	12.4	11.4	11.4
LnGrp LOS	B	B	B	A	B	A	B	B	B	B	B	B
Approach Vol, veh/h		447			502			312			344	
Approach Delay, s/veh		13.0			10.7			12.2			11.5	
Approach LOS		B			B			B			B	
Timer - Assigned Phs		2	3	4		6	7	8				
Phs Duration (G+Y+Rc), s		15.2	5.8	17.5		15.2	8.1	15.2				
Change Period (Y+Rc), s		5.0	5.0	5.0		5.0	5.0	5.0				
Max Green Setting (Gmax), s		50.0	25.0	50.0		50.0	25.0	50.0				
Max Q Clear Time (g_c+I1), s		4.9	2.3	7.9		8.4	3.2	7.6				
Green Ext Time (p_c), s		0.3	0.0	0.4		0.3	0.0	0.4				
Intersection Summary												
HCM 6th Ctrl Delay				11.8								
HCM 6th LOS				B								

Lanes, Volumes, Timings
 5: Des Moines Memorial Dr & Site Access

07/14/2021



Lane Group	WBL	WBR	NBT	NBR	SBL	SBT
Lane Configurations						
Traffic Volume (vph)	17	4	619	6	2	889
Future Volume (vph)	17	4	619	6	2	889
Ideal Flow (vphpl)	1900	1900	1900	1900	1900	1900
Link Speed (mph)	25		30			35
Link Distance (ft)	502		545			385
Travel Time (s)	13.7		12.4			7.5
Peak Hour Factor	0.92	0.92	0.92	0.92	0.92	0.92
Heavy Vehicles (%)	6%	25%	0%	17%	50%	0%
Shared Lane Traffic (%)						
Sign Control	Stop		Free			Free

Intersection Summary

Area Type: Other

Control Type: Unsignalized

HCM 6th TWSC
5: Des Moines Memorial Dr & Site Access

07/14/2021

Intersection						
Int Delay, s/veh	0.6					
Movement	WBL	WBR	NBT	NBR	SBL	SBT
Lane Configurations	↔		↔			↔
Traffic Vol, veh/h	17	4	619	6	2	889
Future Vol, veh/h	17	4	619	6	2	889
Conflicting Peds, #/hr	0	0	0	0	0	0
Sign Control	Stop	Stop	Free	Free	Free	Free
RT Channelized	-	None	-	None	-	None
Storage Length	0	-	-	-	-	-
Veh in Median Storage, #	0	-	0	-	-	0
Grade, %	0	-	0	-	-	0
Peak Hour Factor	92	92	92	92	92	92
Heavy Vehicles, %	6	25	0	17	50	0
Mvmt Flow	18	4	673	7	2	966

Major/Minor	Minor1	Major1	Major2		
Conflicting Flow All	1647	677	0	0	680
Stage 1	677	-	-	-	-
Stage 2	970	-	-	-	-
Critical Hdwy	6.46	6.45	-	-	4.6
Critical Hdwy Stg 1	5.46	-	-	-	-
Critical Hdwy Stg 2	5.46	-	-	-	-
Follow-up Hdwy	3.554	3.525	-	-	2.65
Pot Cap-1 Maneuver	107	415	-	-	724
Stage 1	497	-	-	-	-
Stage 2	362	-	-	-	-
Platoon blocked, %			-	-	-
Mov Cap-1 Maneuver	106	415	-	-	724
Mov Cap-2 Maneuver	106	-	-	-	-
Stage 1	497	-	-	-	-
Stage 2	360	-	-	-	-

Approach	WB	NB	SB
HCM Control Delay, s	40.5	0	0
HCM LOS	E		

Minor Lane/Major Mvmt	NBT	NBR	WBLn1	SBL	SBT
Capacity (veh/h)	-	-	124	724	-
HCM Lane V/C Ratio	-	-	0.184	0.003	-
HCM Control Delay (s)	-	-	40.5	10	0
HCM Lane LOS	-	-	E	A	A
HCM 95th %tile Q(veh)	-	-	0.6	0	-

Lanes, Volumes, Timings
 6: 12th PI S/West Site Access & S 200th St

07/14/2021



Lane Group	EBL	EBT	EBR	WBL	WBT	WBR	NBL	NBT	NBR	SBL	SBT	SBR
Lane Configurations												
Traffic Volume (vph)	1	360	16	14	462	2	8	0	8	2	0	6
Future Volume (vph)	1	360	16	14	462	2	8	0	8	2	0	6
Ideal Flow (vphpl)	1900	1900	1900	1900	1900	1900	1900	1900	1900	1900	1900	1900
Link Speed (mph)		35			35			25			25	
Link Distance (ft)		538			274			315			219	
Travel Time (s)		10.5			5.3			8.6			6.0	
Confl. Peds. (#/hr)			3	3								
Peak Hour Factor	0.91	0.91	0.91	0.91	0.91	0.91	0.91	0.91	0.91	0.91	0.91	0.91
Heavy Vehicles (%)	0%	1%	0%	0%	2%	50%	0%	0%	0%	50%	0%	0%
Shared Lane Traffic (%)												
Sign Control		Free			Free			Stop			Stop	

Intersection Summary

Area Type: Other
 Control Type: Unsignalized

HCM 6th TWSC
6: 12th PI S/West Site Access & S 200th St

07/14/2021

Intersection												
Int Delay, s/veh	0.5											
Movement	EBL	EBT	EBR	WBL	WBT	WBR	NBL	NBT	NBR	SBL	SBT	SBR
Lane Configurations		↕			↕			↕			↕	
Traffic Vol, veh/h	1	360	16	14	462	2	8	0	8	2	0	6
Future Vol, veh/h	1	360	16	14	462	2	8	0	8	2	0	6
Conflicting Peds, #/hr	0	0	3	3	0	0	0	0	0	0	0	0
Sign Control	Free	Free	Free	Free	Free	Free	Stop	Stop	Stop	Stop	Stop	Stop
RT Channelized	-	-	None	-	-	None	-	-	None	-	-	None
Storage Length	-	-	-	-	-	-	-	-	-	-	-	-
Veh in Median Storage, #	-	0	-	-	0	-	-	0	-	-	0	-
Grade, %	-	0	-	-	0	-	-	0	-	-	0	-
Peak Hour Factor	91	91	91	91	91	91	91	91	91	91	91	91
Heavy Vehicles, %	0	1	0	0	2	50	0	0	0	50	0	0
Mvmt Flow	1	396	18	15	508	2	9	0	9	2	0	7

Major/Minor	Major1			Major2			Minor1			Minor2		
Conflicting Flow All	510	0	0	417	0	0	953	950	408	951	958	509
Stage 1	-	-	-	-	-	-	410	410	-	539	539	-
Stage 2	-	-	-	-	-	-	543	540	-	412	419	-
Critical Hdwy	4.1	-	-	4.1	-	-	7.1	6.5	6.2	7.6	6.5	6.2
Critical Hdwy Stg 1	-	-	-	-	-	-	6.1	5.5	-	6.6	5.5	-
Critical Hdwy Stg 2	-	-	-	-	-	-	6.1	5.5	-	6.6	5.5	-
Follow-up Hdwy	2.2	-	-	2.2	-	-	3.5	4	3.3	3.95	4	3.3
Pot Cap-1 Maneuver	1065	-	-	1153	-	-	241	262	648	197	259	568
Stage 1	-	-	-	-	-	-	623	599	-	449	525	-
Stage 2	-	-	-	-	-	-	528	524	-	532	593	-
Platoon blocked, %	-	-	-	-	-	-	-	-	-	-	-	-
Mov Cap-1 Maneuver	1065	-	-	1150	-	-	234	256	646	191	253	568
Mov Cap-2 Maneuver	-	-	-	-	-	-	234	256	-	191	253	-
Stage 1	-	-	-	-	-	-	621	597	-	449	516	-
Stage 2	-	-	-	-	-	-	512	515	-	524	591	-

Approach	EB			WB			NB			SB		
HCM Control Delay, s	0			0.2			16			14.7		
HCM LOS							C			B		

Minor Lane/Major Mvmt	NBLn1	EBL	EBT	EBR	WBL	WBT	WBR	SBLn1
Capacity (veh/h)	344	1065	-	-	1150	-	-	380
HCM Lane V/C Ratio	0.051	0.001	-	-	0.013	-	-	0.023
HCM Control Delay (s)	16	8.4	0	-	8.2	0	-	14.7
HCM Lane LOS	C	A	A	-	A	A	-	B
HCM 95th %tile Q(veh)	0.2	0	-	-	0	-	-	0.1

Lanes, Volumes, Timings
7: S 200th St & East Site Access

07/14/2021

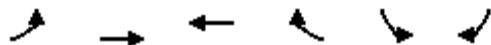

Lane Group	EBL	EBT	WBT	WBR	SBL	SBR
Lane Configurations						
Traffic Volume (vph)	1	368	483	6	17	1
Future Volume (vph)	1	368	483	6	17	1
Ideal Flow (vphpl)	1900	1900	1900	1900	1900	1900
Link Speed (mph)		30	35		25	
Link Distance (ft)		256	549		207	
Travel Time (s)		5.8	10.7		5.6	
Peak Hour Factor	0.92	0.92	0.92	0.92	0.92	0.92
Heavy Vehicles (%)	0%	1%	0%	33%	6%	0%
Shared Lane Traffic (%)						
Sign Control		Free	Free		Stop	

Intersection Summary

Area Type: Other
Control Type: Unsignalized

Intersection						
Int Delay, s/veh	0.4					
Movement	EBL	EBT	WBT	WBR	SBL	SBR
Lane Configurations		↕	↕		↕	
Traffic Vol, veh/h	1	368	483	6	17	1
Future Vol, veh/h	1	368	483	6	17	1
Conflicting Peds, #/hr	0	0	0	0	0	0
Sign Control	Free	Free	Free	Free	Stop	Stop
RT Channelized	-	None	-	None	-	None
Storage Length	-	-	-	-	0	-
Veh in Median Storage, #	-	0	0	-	0	-
Grade, %	-	0	0	-	0	-
Peak Hour Factor	92	92	92	92	92	92
Heavy Vehicles, %	0	1	0	33	6	0
Mvmt Flow	1	400	525	7	18	1

Major/Minor	Major1	Major2	Minor2		
Conflicting Flow All	532	0	-	0	931 529
Stage 1	-	-	-	-	529 -
Stage 2	-	-	-	-	402 -
Critical Hdwy	4.1	-	-	-	6.46 6.2
Critical Hdwy Stg 1	-	-	-	-	5.46 -
Critical Hdwy Stg 2	-	-	-	-	5.46 -
Follow-up Hdwy	2.2	-	-	-	3.554 3.3
Pot Cap-1 Maneuver	1046	-	-	-	291 554
Stage 1	-	-	-	-	583 -
Stage 2	-	-	-	-	667 -
Platoon blocked, %		-	-	-	
Mov Cap-1 Maneuver	1046	-	-	-	291 554
Mov Cap-2 Maneuver	-	-	-	-	291 -
Stage 1	-	-	-	-	582 -
Stage 2	-	-	-	-	667 -

Approach	EB	WB	SB
HCM Control Delay, s	0	0	17.9
HCM LOS			C

Minor Lane/Major Mvmt	EBL	EBT	WBT	WBR	SBLn1
Capacity (veh/h)	1046	-	-	-	299
HCM Lane V/C Ratio	0.001	-	-	-	0.065
HCM Control Delay (s)	8.4	0	-	-	17.9
HCM Lane LOS	A	A	-	-	C
HCM 95th %tile Q(veh)	0	-	-	-	0.2

Appendix C

Detailed Trip Generation Calculations

**Bridge Maywood Site (SeaTac, WA)
Trip Generation Summary**

Land Use	Units ¹	ITE LUC ²	Directional Distribution		Trip Rate ²	Trips Generated			Trip Rate ²	Directional Distribution			Truck Trip Generation			Non-Truck Trip Generation		
			In	Out		In	Out	Total		In	Out	Enter	Exit	Total	Enter	Exit	Total	
Daily																		
Proposed Use:																		
Warehousing	310,000 GFA	150	50%	50%	T = 1.58(X)+45.54	267	268	535	0.60	50%	50%	93	93	186	174	175	349	
Existing Use:																		
Single-Family Detached Housing	6 DU	210	50%	50%	9.44	-28	-29	-57	-	-	-	-	-	-	-28	-29	-57	
Net New Daily Trips =						239	239	478				93	93	186	146	146	292	
AM Peak Hour																		
Proposed Use:																		
Warehousing	310,000 GFA	150	77%	23%	T = 0.12(X)+25.32	49	14	63	0.02	52%	48%	3	3	6	46	11	57	
Existing Use:																		
Single-Family Detached Housing	6 DU	210	25%	75%	0.74	-1	-3	-4	-	-	-	-	-	-	-1	-3	-4	
Net New AM Peak Hour Trips =						48	11	59				3	3	6	45	8	53	
Afternoon Peak Hour																		
Proposed Use:																		
Warehousing ³	310,000 GFA	150	50%	50%	0.12	18	19	37	0.04	57%	43%	6	5	11	12	14	26	
Existing Use:																		
Single-Family Detached Housing ⁴	6 DU	210	50%	50%	0.67	-2	-2	-4	-	-	-	-	-	-	-2	-2	-4	
Net New Mid-Afternoon Peak Hour Trips =						16	17	33				6	5	11	10	12	22	
PM Peak Hour																		
Proposed Use:																		
Warehousing	310,000 GFA	150	27%	73%	T = 0.12(X)+27.82	18	47	65	0.03	52%	48%	5	4	9	13	43	56	
Existing Use:																		
Single-Family Detached Housing	6 DU	210	63%	37%	0.99	-4	-2	-6	-	-	-	-	-	-	-4	-2	-6	
Net New PM Peak Hour Trips =						14	45	59				5	4	9	9	41	50	

Notes:

¹ GFA = Gross Floor Area.

² Land Use Code and trip rates based on ITE *Trip Generation Manual*, 10th Edition (2017) and 10th Edition Supplement (2020).

³ Afternoon Peak Hour trip rate for LUC 150 based on 7% of Daily Total Trips and 6.1% of Daily Truck Trips for period of 2:00-3:00 PM per ITE *Trip Generation Manual*, 10th Edition (2017) and Supplement (2020).

⁴ Afternoon Peak Hour trip rate for LUC 210 based on 6.6% of Daily Total Trips for period of 2:00-3:00 PM per ITE *Trip Generation Manual*, 10th Edition (2017). Directional distribution percentages based on Daily percentages.